



GENUINE PARTS

INSTALLATION INSTRUCTIONS

DESCRIPTION: Auto Dimming Mirror with Homelink® and Compass

APPLICATION: Sentra

PART NUMBER: 999L1 VZ001

KIT CONTENTS:

Item	Qty.	Part Description	Service Part Number
A	1	EC Compass Homelink® Mirror	999L1 VZ000
B	1	Parts Kit	999L1 VZ002
C	1	Harness Assembly - Ignition, Battery and Ground	
D	1	Wire Cover	
E	3	Posi-tap	
F	9	Wire Tie	
G	9	Foam Tape	
H	2	A-Pillar Clip	76988 3DN0A
I	1	Manual, Installation Instruction Download	999V2 AW000
J	1	User Guide	
K	1	Homelink® User Guide	
L	1	Accessory Service Connector (NOT INCLUDED IN KIT)	999Q9 AY000

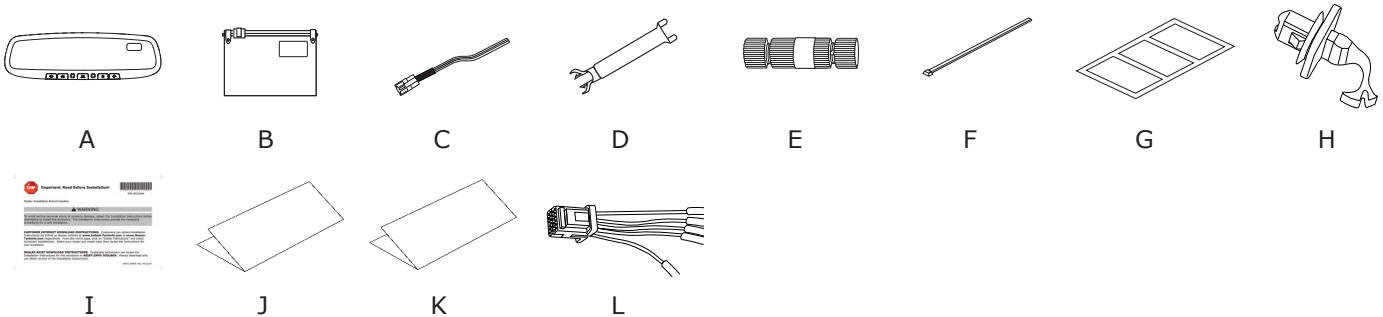

TOOLS REQUIRED:

- | | | |
|-----------------------|-------------------------|------------|
| Phillips Screwdriver | 10mm Socket Wrench | Clean Rag |
| 3mm Flat Scredriver | Side Cutters | Shop Light |
| T-20 Torx Head Driver | Long Needle Nose Pliers | |
| Panel Removal Tool | | |

PRE-INSTALLATION WARNINGS, CAUTIONS, CRITICAL STEPS, and NOTES:

- Dealer Installation Recommended. Instructions may refer to Service Manual.

⚠ CAUTION

- This is a universal kit so all parts may not be used.
- Place removed vehicle trim components in a clean, dry area to prevent damage.

HOMELINK® AND THE HOMELINK HOUSE® ARE REGISTERED TRADEMARKS OF JOHNSON CONTROLS, INC.

INSTALLATION PROCEDURE:

- 1) Apply parking brake.
- 2) Confirm the vehicle is no longer in the default shipping state (extended storage switch pulled up and BCM in transit mode). Failure to confirm the vehicle has been removed from this state will result in loss of normal vehicle operation. The confirmation requires two checks:
 - 2a) Locate the extended storage switch in the cabin fuse block. Once located, check that it is in the "customer" position. See below for reference.
 - 2B) To remove transit mode is by doing as follows:
 1. Remove fuse cover lid
 2. Push down shorting pin
 3. Ign on 2 times without turn the vehicle on.

**Inventory
PULL UP**

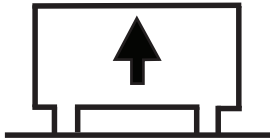

INCORRECT

**Customer
PULL DOWN**

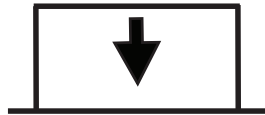

CORRECT

To put transit mode back is by doing as follows:

1. Ign Off
2. Remove fuse cover lid
3. Pull up shorting pin
4. Assemble fuse cover lid
5. Ign On 2 times without turn the vehicle on.
6. Confirm transit mode condition on meter.

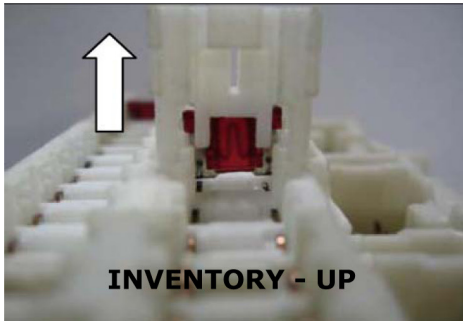

INVENTORY - UP

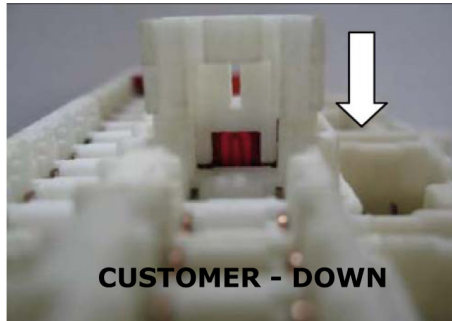

CUSTOMER - DOWN

- 3) Record the customer radio presets and other presets as required.
- 4) Turn ignition switch to "ON" position.

Presets	1	2	3	4	5	6	

- 5) Put shift lever in "P" position for A/T and CVT or "1st" for M/T.
- 6) Turn ignition switch to "OFF" position.

INSTALLATION PROCEDURE:

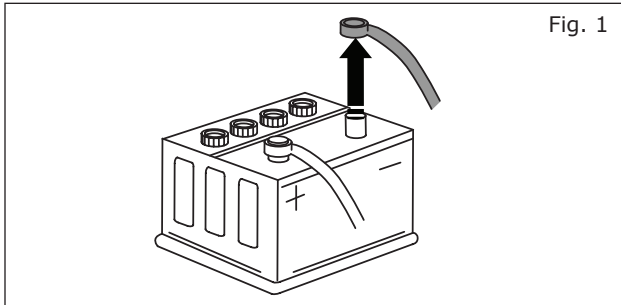

- 7) Disconnect the negative battery terminal.

⚠ CAUTION

Do not use excessive force when removing OE mirror from windshield. The window button may separate from windshield or the windshield could break.

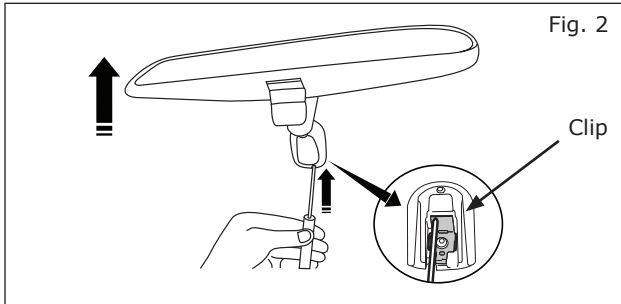

- 8) Removal of OE rearview mirror.
- Slide flat end of 3mm screwdriver into opening at bottom of mirror mount until resistance is felt.
 - Apply additional upward force and twist 90 degrees to lift lock spring.
 - Lift mirror upward off mirror mount while applying pressure with screwdriver.

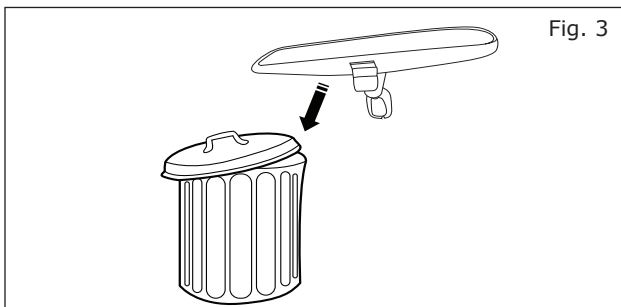
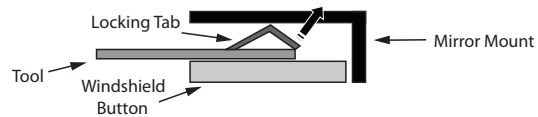

- d) Discard Mirror

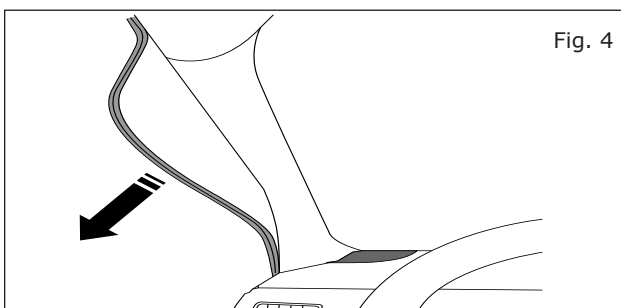

- 9) Using panel removal tool, loosen driver side weather strip. Remove from top of A-pillar.

INSTALLATION PROCEDURE:

CAUTION

- Exercise caution when removing and installing LH front pillar garnish due to side airbag placement. Reference Figure 5 below for further detail.
- Do **NOT** re-use LH front pillar garnish clips. LH front pillar garnish clips (P/N 76988 3DN0A) **MUST** be replaced during re-installation of garnish.

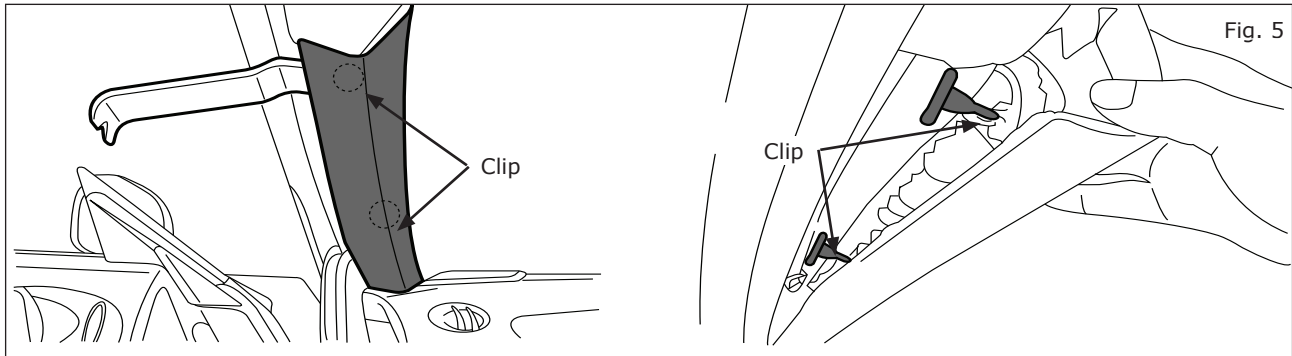

- 10) Disengage driver side front pillar garnish fixing clip and metal clip with panel removal tool, cut clip A with cutter knife and then remove front pillar garnish.
 - a) Remove and discard the clips from the vehicle.

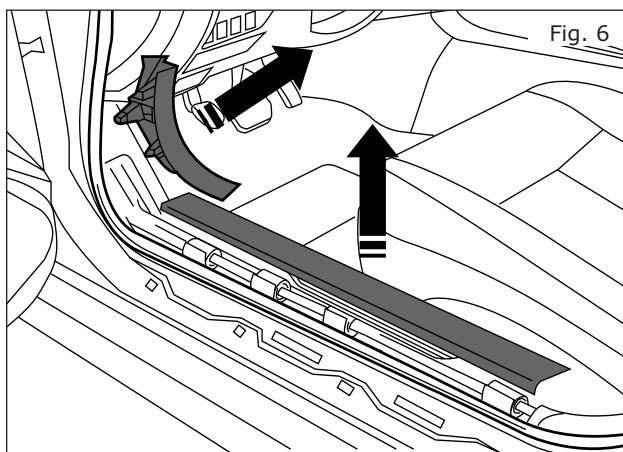

- 11) Remove the door sill plate and kick panel from the driver side of the vehicle.
 - a) Pull up sill plate to disengage the pawls. (Fig. 6)
 - b) Remove the sill plate from the body panel.
 - c) Remove kick panel fixing clips with a panel removal tool and then remove the kick panel. (Fig. 6)

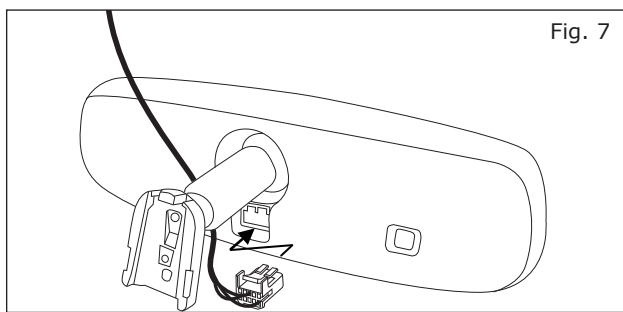

- 12) Install Auto-Dimming mirror.
 - a) Plug harness connector into back of mirror (Fig. 7).

INSTALLATION PROCEDURE:

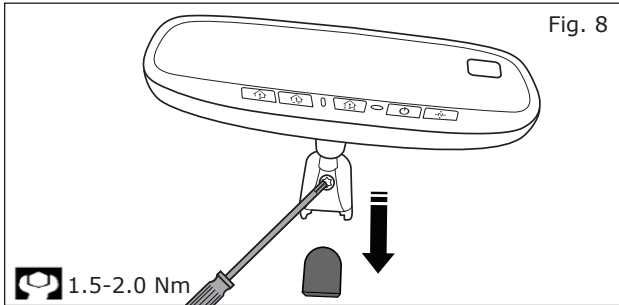

- 13) Slide mirror base over button on windshield. Using a T-20 torx head driver, tighten the screw on the mirror mount to **1.5 - 2.0 Nm (13.25-17.75 in-lb)**. (Fig. 8)

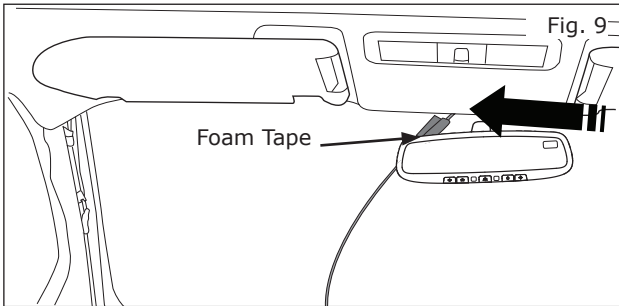

- 14) Wrap 1 piece of foam tape around harness and using panel removal tool, tuck between headliner and roof above mirror.

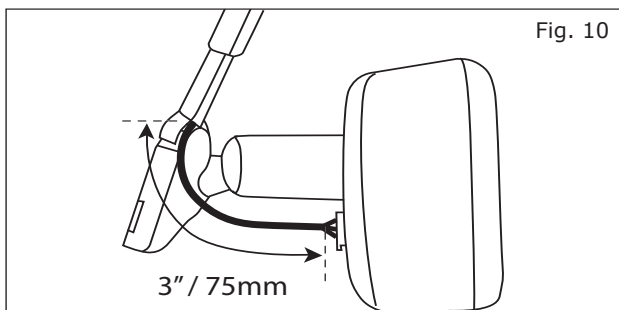

- 15) Verify that a approximately 3" (75mm) of wire are between the bottom of the wire cover and connector on the back of the mirror. Failure to allow the appropriate length will result in limited to no movement for the mirror. (Fig. 10)

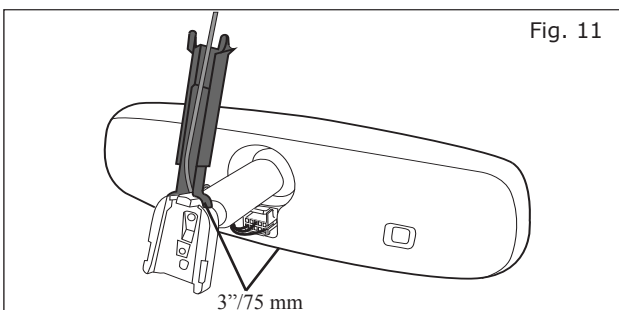

- 16) If a wire cover was removed from the OE mirror, discard the OE wire cover and use the new wire cover from kit contents. All 3" of wire to remain exposed from the back of the mirror to the wire cover.
- Route harness into the groove of the wire cover and attach to the mirror mount.
 - Slide the forks on top of the wire cover, into the headliner. (Fig. 11)
 - Verify cover is properly seated and aligned.

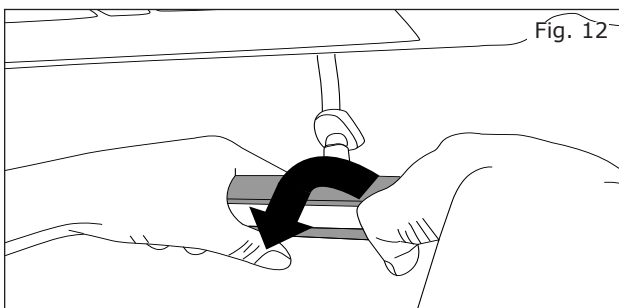

- 17) Grasp the mirror and rotate downward. Check to ensure wire cover sits flush against the windshield. (Fig. 12)
- If there is a gap between the wire cover and the windshield, ensure there is enough harness slack from the mirror to the headliner. Adjust if necessary.
 - Rotate the mirror in a circular motion to verify the proper adjustment range.

INSTALLATION PROCEDURE:

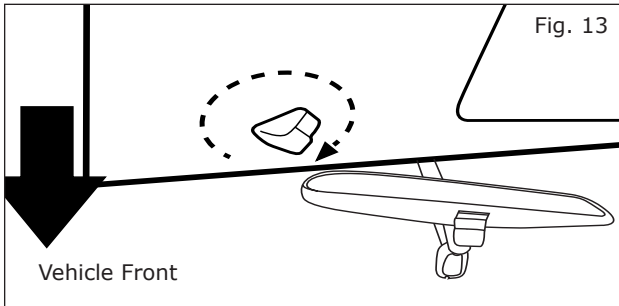

- 18) Remove the sunvisor clip from the headliner by twisting the clip in a clockwise rotation. (Fig. 13)

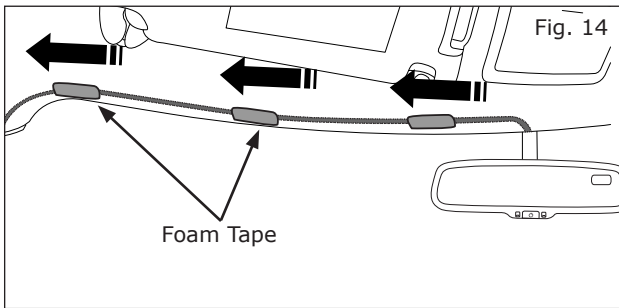

- 19) Wrap two pieces of foam tape around the mirror harness at the center of the sunvisor and where the head-line meets the A-pillar.

Note: Space the foam tape approximately 6" apart from each other on the harness.

- a) Using a panel removal tool, tuck the wire harness between the headliner and the roof. (Fig. 14)

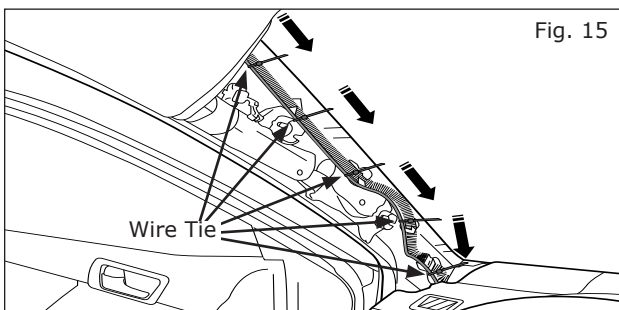

- 20) Route the harness down the driver side A-pillar and secure to the existing vehicle harness with 5 wire ties. (Fig. 15)

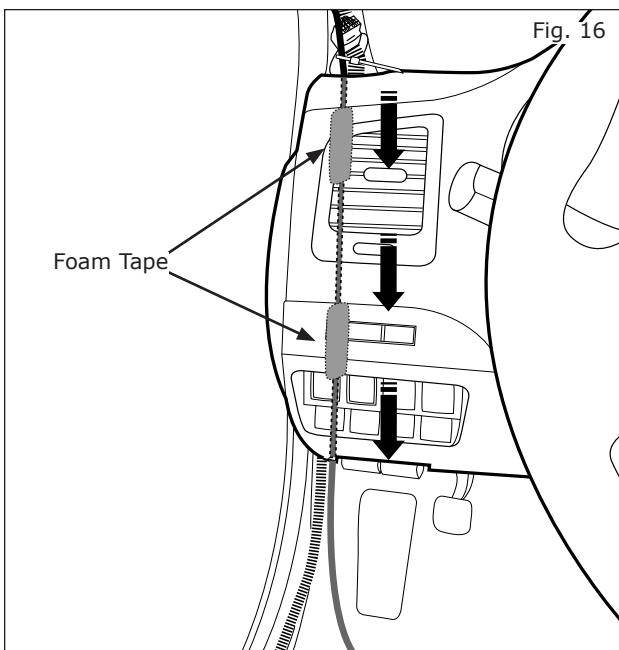

- 21) Wrap 2 pieces of foam tape around the mirror harness and feed the harness through the top of the dash near the a-pillar. Feed the harness from the upper dash to the lower driver side kick panel area. Secure the EC mirror harness to the body harness in the driver side kick panel area with 2 wire ties. (Fig. 16)

INSTALLATION PROCEDURE:

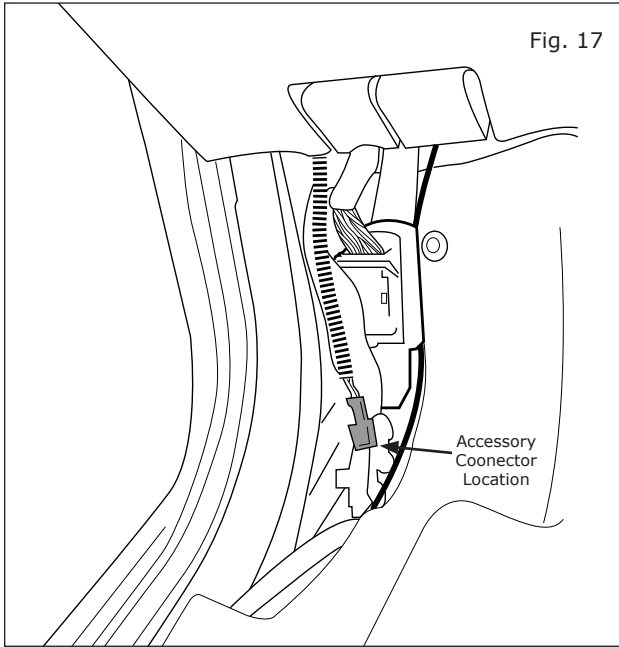

- 22) Locate the accessory connector harness near the main body harness in the driver side kick panel area.
 - a) Unplug the accessory connector

CAUTION

This Accessory Service Connector is for use only with Genuine Nissan (or Infiniti) or Nissan (or Infiniti) approved accessories. Use of this connector with non Genuine Nissan (or Infiniti) or Nissan (or Infiniti) approved accessories or failure to follow the installation instructions for the connector contained in this package may result in damage to the accessory and/or your vehicle. Nissan (or Infiniti) is not liable for loss or damage due to improper installation or the installation of non Genuine or non approved accessories.

Posi-Tap™ is protected by patent # 5,228,875 5,695,369 5,868,589 6,692,313 Jap 2881414 Aus 708700 Tia 103534 Can 2204826 Mex 200626 Korea 477279 China Z197105562.9 & others pending.

PIN #	Function	Color
1	BAT	R
2	N/A	
3	ACC	O
4	N/A	
5	BATT SVR	P
6	DOOR	G
7	CROSS 2	L
8	CROSS 1	SB
9	N/A	
10	RM LMP	Y
11	N/A	
12	GND	B

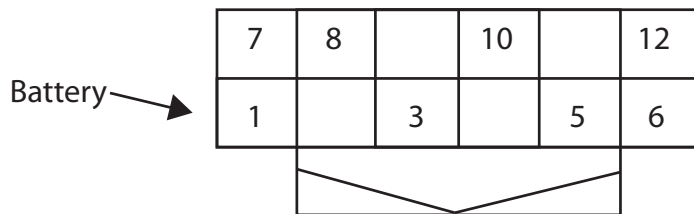
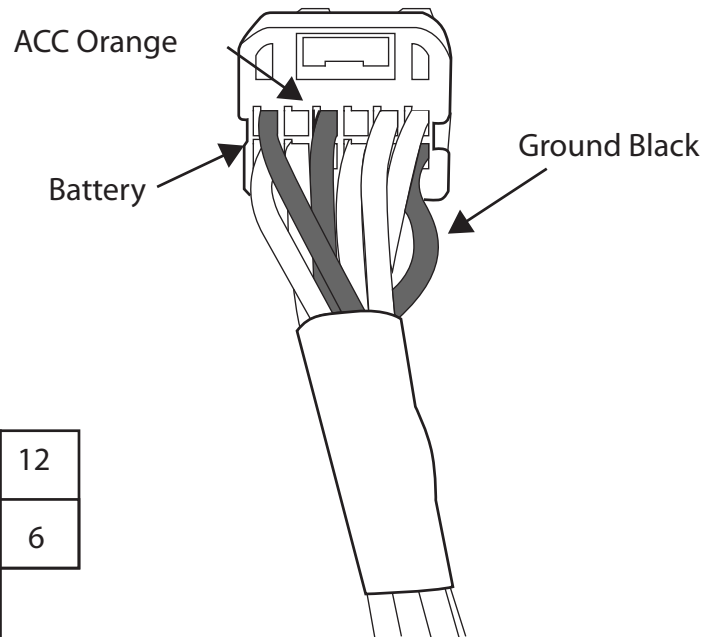

Pin location is referenced looking into the face of connector.

INSTALLATION PROCEDURE:

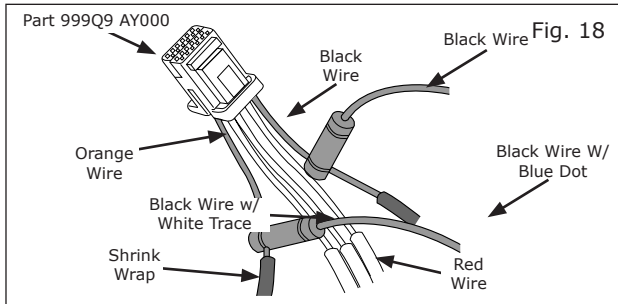

- 23) Using a posi-tap, connect the BLACK WIRE from the mirror harness to the BLACK wire on the accessory connector harness. Using a posi-tap, connect the BLACK WIRE W/WHITE TRACE from the mirror harness to the ORANGE wire on the accessory connector harness. Using a posi-tap, connect the BLACK WIRE WITH THE BLUE DOT from the mirror harness to the RED wire on the accessory connector harness. (Fig. 18)
- See Step 24 - 28 for posi tap installation instructions.

Note: Be sure NOT to posi-tap through the shrink tubing.

**HARNESS NOT INCLUDED IN KIT.
REFERENCE PART NUMBER
999Q9 AY000**

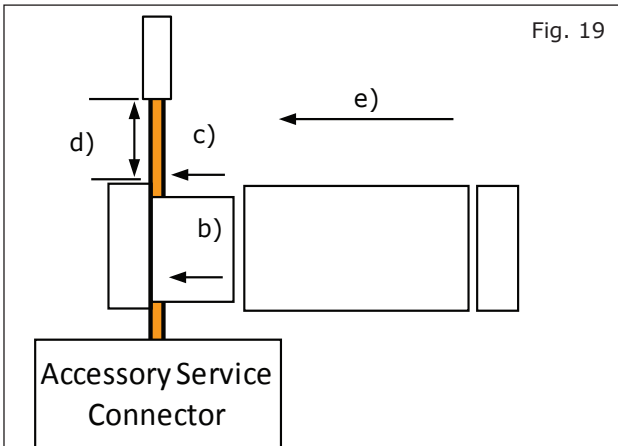

- 24) Tap accessory service wire. (Fig. 19)
- Identify and confirm correct wire in the Accessory Service Connector to be tapped.
 - Remove cap (slot side) from tap body.
 - Slide cap around single accessory wire.
 - Position cap $\geq 6.35\text{mm}(0.25\text{in})$ away from the heat shrink end of the Accessory Service Connector (measurement for first posi-tap installed on the circuit).
 - Tighten the tap **TIGHT** with finger pressure.
 - Tighten by another quarter turn.

NOTE: Figures are not to scale.

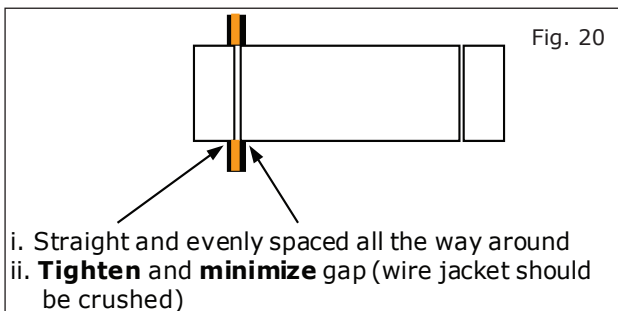

- 25) Inspect the tap to ensure correct installation. (Fig. 20)
- Pull on wire lightly to ensure connection.
 - Inspect the tap to ensure correct installation.
 - Test signal to ensure that it is working.

NOTE: Avoid putting pressure on the vehicle wire and tap for the remainder of the installation.

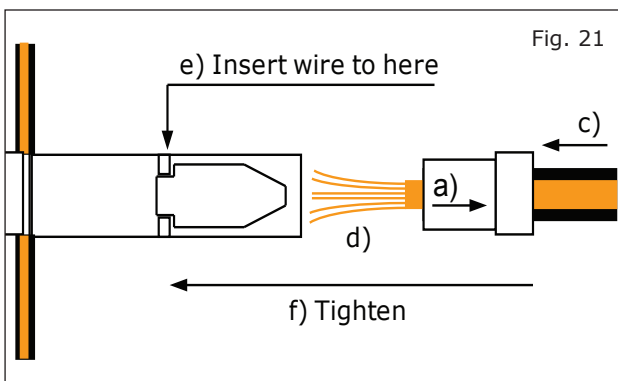

- 26) Tap accessory wire. (Fig. 21)
- Remove tap (non-pierce) side from tap.
 - Remove the protective stub from the wire.
 - Insert wire through the non-pierce side.
 - Spread the individual strands into fan shape.
 - Insert wire into the tap body and ensure that it is all the way in.
 - Tighten the tap **TIGHT** with finger pressure.
 - Tighten by another quarter turn.

INSTALLATION PROCEDURE:

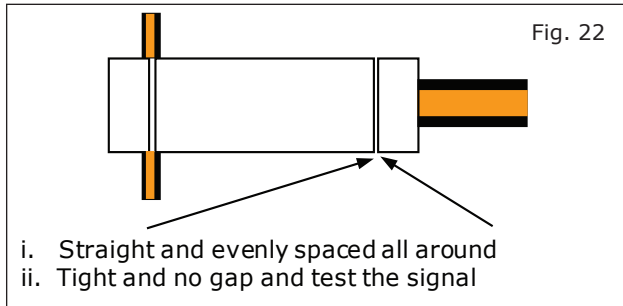

- 27) Confirm the tapped accessory wire. (Fig. 22)
- Pull on the wire lightly to ensure connection.
 - Inspect the tap to ensure correct installation.
 - Test the signal to ensure it is working.

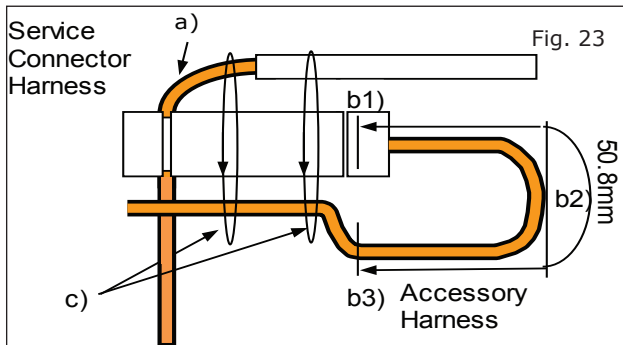

- 28) Forming strain relief loop (always required). (Fig. 23)
- Gently bend the end of the pierced wire (where it exits the cap) down toward the body of the posi-tap.
 - On the tapped wire of the non-pierce side; starting at point b1) measure 50.8mm(2in.) to point b3). Make the first bend of the loop b2), half the distance measured 25.4mm(1in.), and up toward the body of the posi-tap, make the second bend of the loop b3).
 - Secure the pierced wire on the heat shrink side and the tapped wire on the non-pierce side to the body of the tap with electrical tape (≥ 2 Revolutions).

NOTE: If securing multiple taps to single circuit continue to Step 29, if tapping different circuits repeat steps 24-28 as required, then proceed to step 33.

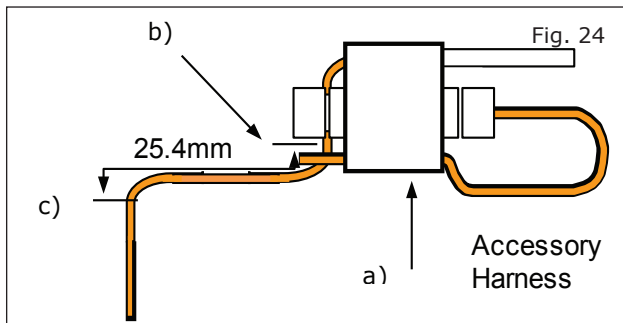

- 29) Multiple posi-taps on the same wire; first tap. (Fig. 24)
- The first accessory is tapped, relieved and secured as shown in Fig 19 thru 23 (these steps are always the same).
 - Measure 25.4mm(1in) from point b) to point c) on the pierced wire.
 - At points b) & c), bend the pierced wire gently to form the "staircase" shape.

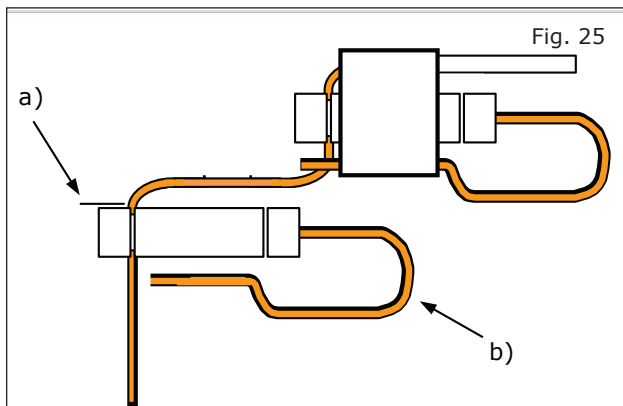

- 30) Multiple posi-taps; second accessory. (Fig. 25)
- Tap second accessory at point b), making sure to preserve "staircase" shape".
 - After tapping second accessory, form a strain relief loop for the tapped wire on the non-pierce side as shown in Fig c) and detailed in step 5b.

NOTE: Do not secure before reading step 31. Repeat as necessary.

INSTALLATION PROCEDURE:

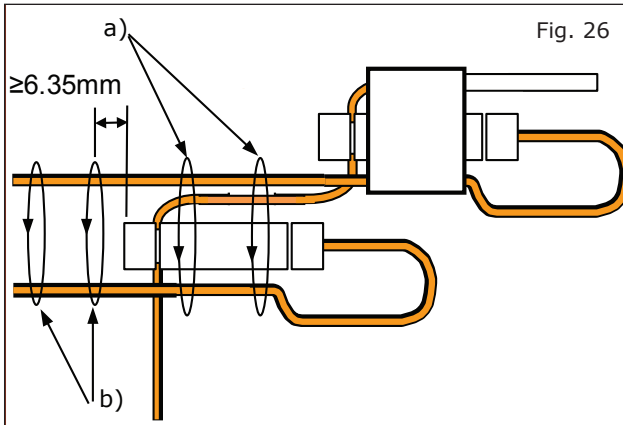

- 31) Securing multiple posi-taps on the same circuit (Fig. 26)
- Secure the pierced and tapped wires from the first posi-tap, along with the tapped wire from the non pierce side of the 2nd posi-tap to the body of the 2nd tap with electrical tape (≥ 2 revolutions).
 - Secure the tapped wires from the non-pierced sides of each tap to each other with electrical tape (≥ 2 revolutions) at a distance of $\geq 6.35\text{mm}$ (0.25in) from the head of last posi-tap shown in Fig b).

Note: No single wire should be posi-tapped more than 4 times to maintain integrity. Repeat as necessary

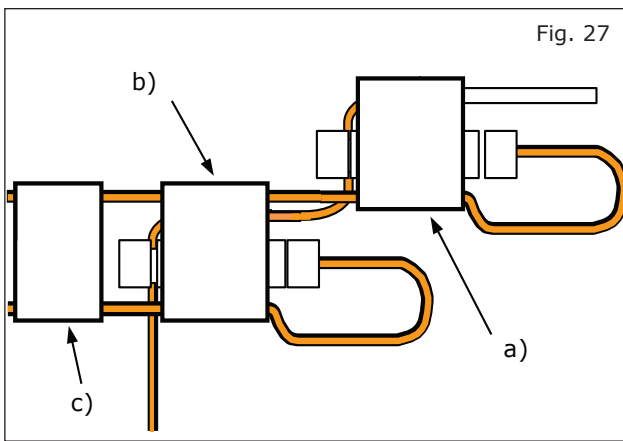

- 32) Multiple accessory taps on the same circuit secured. (Fig. 27)
- The first accessory is tapped, relieved and has the pierced wire on the heat shrink side and the tapped wire on the non-pierce side secured to the first tap as shown in Fig a).
 - The second accessory is tapped, relieved and has the pierced wire, the tapped wire on the non-pierce side and the tapped wire from the non-pierce side of the first posi-tap secured to the second tap as shown in Fig b).
 - Finally the tapped wires on the non-pierce side of the first and subsequent posi-taps are secured to each other as shown in Fig c).

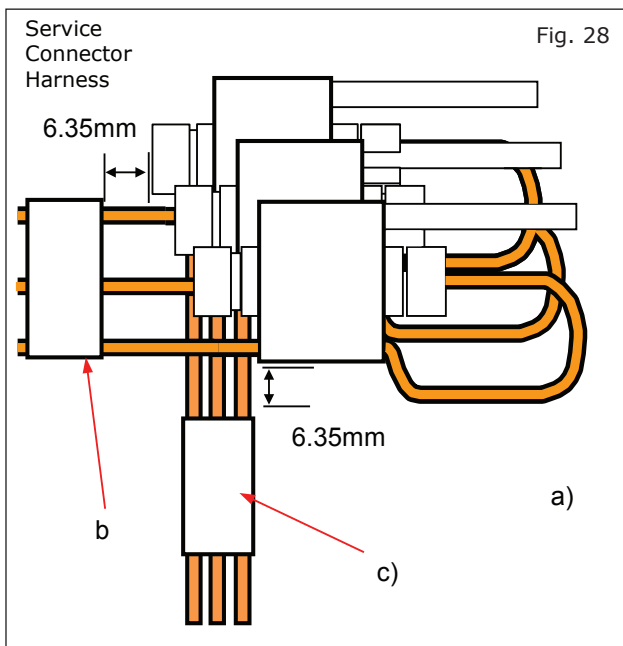

- 33) Multiple accessory taps on different circuits secured together. (Fig. 28)
- The tapped accessories (with wires already secured to tap bodies) are stacked slightly staggered on top of each other as shown in Fig a).
 - The tapped wires on the non-pierce side of all the posi-taps are secured to each other with electrical tape (≥ 2 revolutions) at a distance of $\geq 6.35\text{mm}$ (0.25in) as shown in Fig b).
 - The pierced wires of the first and subsequent posi-taps are secured to each other with electrical tape (≥ 2 revolutions) at a distance of $\geq 6.35\text{mm}$ (0.25in) as shown in Fig c).

INSTALLATION PROCEDURE:

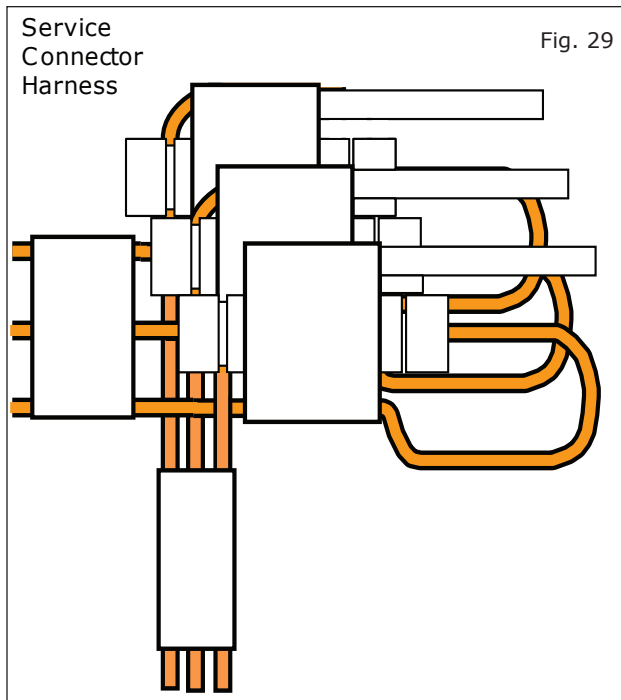

- 34) Prep for foam wrap. (Fig. 29)
- Make sure the accessory taps have been wrapped appropriately as detailed previously and as shown in Fig 1)

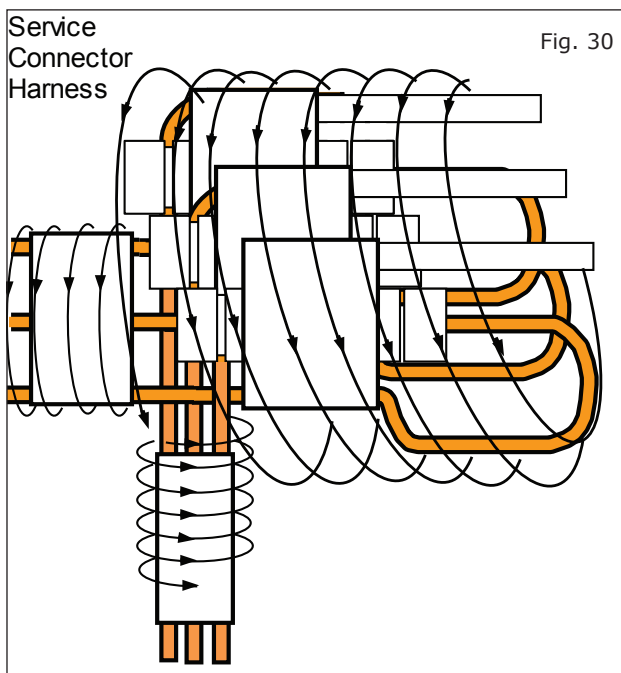

- 35) Pre- foam protective wrap. (Fig. 30)
- Starting at the heat shrink; firmly wrap the posi-tap bundle with electrical tape or non-adhesive wire harness tape, making sure to overlap the previous revolution.

Note: If using non adhesive tape secure at the of wrap with electrical tape ≥ 2 revolutions.

INSTALLATION PROCEDURE:

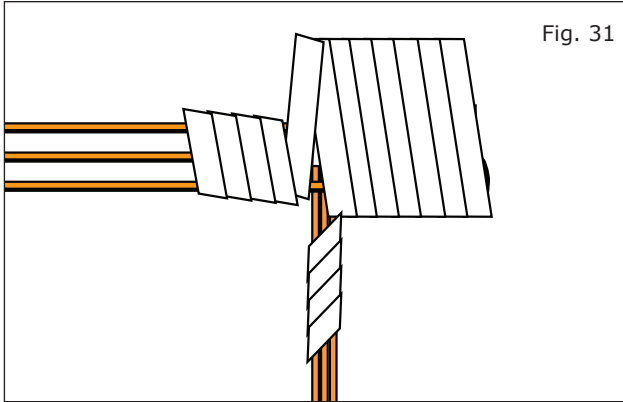

- 36) Finished protective wrap. (Fig. 31)
a) Make sure the finished wrap looks similar to Fig. 3

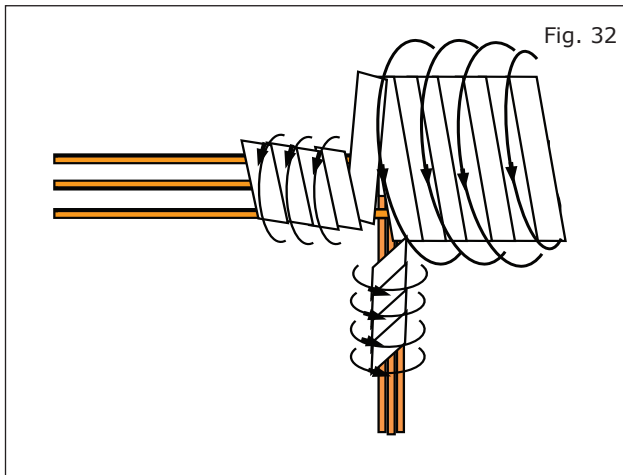

- 37) Foam wrap for posi-tap bundle (foam strips)
(Fig. 32)
a) Wrap the posi-tap bundle with foam tape, following a pattern similar to the electrical tape, making the best use of foam strips provided.

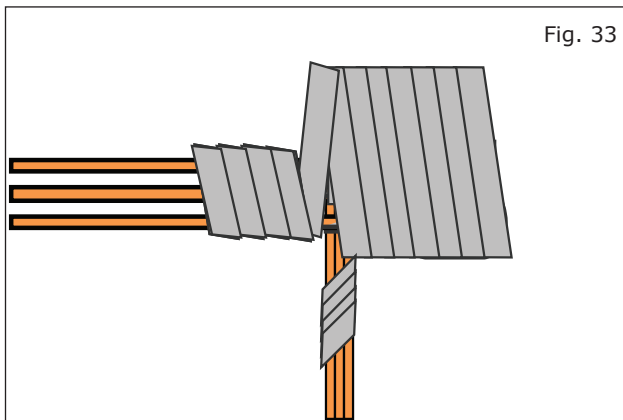

- 38) Finished foam wrap for bundle (strips-top view)
(Fig. 33)
a) Make sure the finished wrap looks similar to Fig. 33

INSTALLATION PROCEDURE:

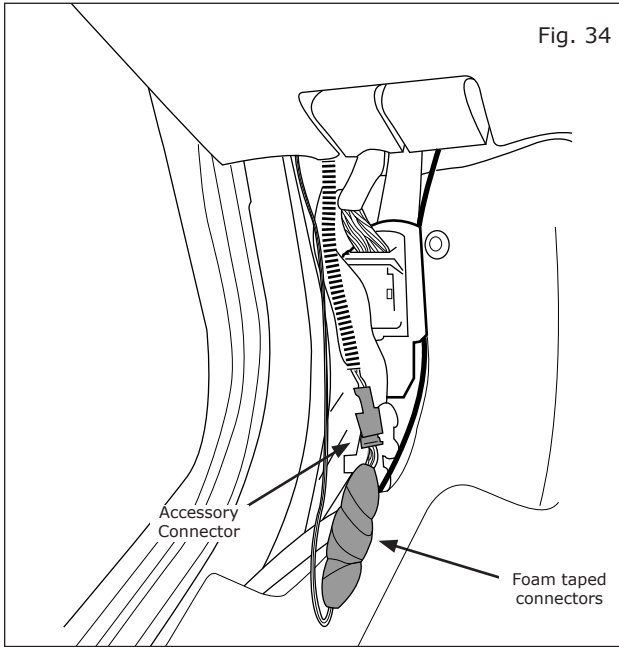

39) Plug in the accessory connector. (Fig. 34)

Note: Be sure the new harness routing does NOT interfere with the emergency brake in any way.

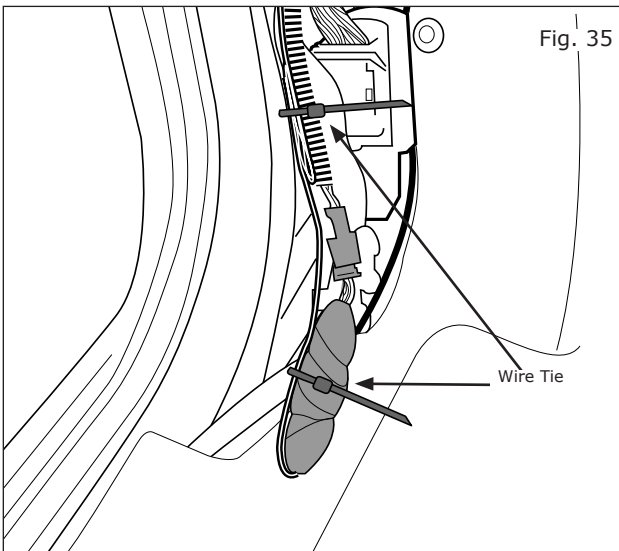

40) Secure the EC mirror harness to the foam tape bundle on the accessory connector. using a wire tie. Bundle any remaining harness wire to the factory harness, and secure with a wire tie. (Fig. 35)

ACCESSORY CHECK:

Testing

- Tighten negative battery terminal nut to 5.4 Nm (47.8 in-lb).
- Turn the ignition switch to ON.
- Ensure vehicle is in well lit area.
- Check to see that the green LED is illuminated. If it is not, press the "⏻" button to turn it on.
- Cover the forward-looking photocell (located to the driver side of the wire harness connection on the back of the mirror) with a dark cloth or towel. After a few seconds, the mirror should begin to darken. Timing will vary with ambient light levels and a flashlight may be shined on the rearward photocell if needed, to accelerate effect.
- Remove the cover from the forward-looking photocell and the mirror will begin to clear.

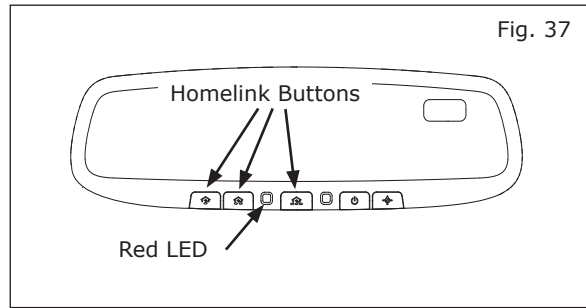
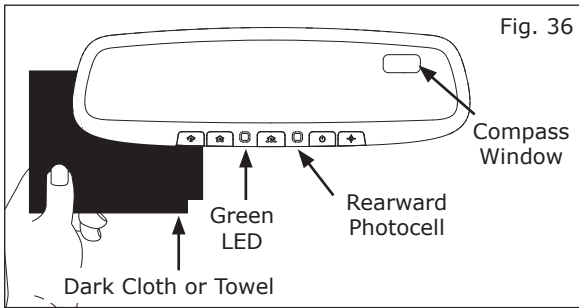

- Push the "N" button to ensure compass display shows either a direction such as "NE" or a "C", and that it can be turned ON and OFF.
- Push each Homelink® button one at a time and verify that the LED indicator to the left of the center switch illuminates with a red LED (Fig. 37).
- Testing is now complete.

Set Compass Zone

- With the display turned "ON", push the "N" button for 3 seconds, until a number appears in display (numbers correspond to regional compass zones).
- Press and release "N" button to scroll through zone numbers.
- Release "N" button when correct zone number is displayed. Zone number will disappear and display will return to showing either a directional heading or a "C" after 5 seconds of no switch activity.

Calibrate Compass

- Drive vehicle in circles (360°) at 5 mph or less until compass display window shows a direction.

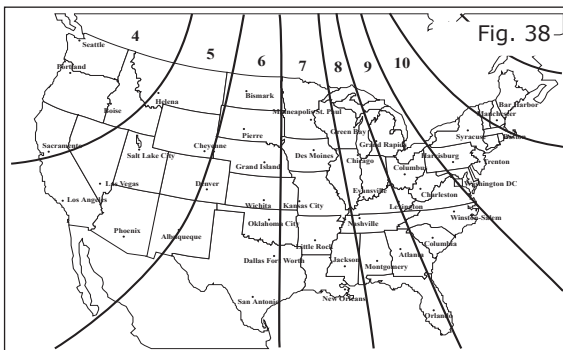

- Diagnostic flow chart is available on last page of instructions for troubleshooting.
- Check all **Critical Installation Steps**.
- Check all torque values
 - Auto-Dimming mirror, pg. 4, step 12, fig. 6

ACCESSORY CHECK:

- Verify all wiring is secure and not exposed.
- Trim all excess cable ties flush.
- Check all vehicle electrical systems that the accessory interfaces with.
 - Power mirror switch.
 - Traction control switch.
 - Hood Release
 - Fuel Door Release

RE-INSTALLATION OF REMOVED PARTS:

⚠ CAUTION

Use caution when re-installing interior components to avoid damage, scratches, or breaking of mounting clips. Refer to the vehicle service manual for more information.

- LH front pillar garnish.
 - Insert new clip (P/N 76988 3DN0A) into garnish hole ensuring long hook faces down.

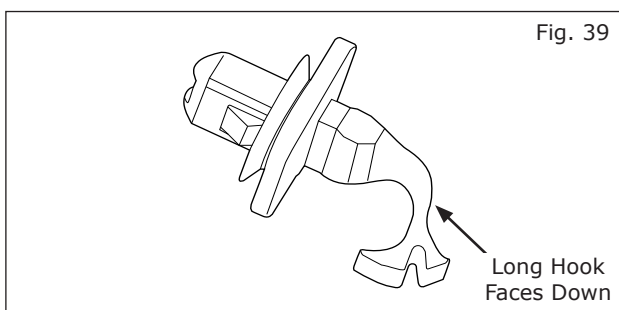

- Insert base of finisher.
- Insert panel removal tool between front pillar garnish bottom side and body side and press clips into body.
- Push garnish toward vehicle body to attach.

FINAL INSPECTION:

- Verify re-installed trim parts for proper flush fit (no gap, no waviness, etc).
- Verify all clips are fully engaged and locked.
- Verify re-installed trim parts are free from cracks, scratches, or stress cracks.
- Verify vehicle headliner, seat, steering wheel, center console, floor carpets, etc. are not soiled.
- Verify interior and exterior is not damaged.
- Turn ignition switch to "ON" and confirm proper operation of Vehicle Systems.
 - If equipped, verify all window and sunroof one touch operation and perform the reset procedure if necessary. Refer to the vehicle service manual for more details.
 - Confirm proper audio function (AM, FM, SAT, CD and AUX).
- Re-program radio presets and other vehicle settings to the recorded settings.
- Start engine and verify that there are no new Diagnostic Trouble Codes. Turn ignition switch to "OFF".
- Place the Owner Manual, Quick Reference Guide, and/or other Manual in the glove box.

DIAGNOSTIC FLOW CHART:

Before attempting to trouble-shoot EC mirror Auto-Dimming function, ensure the following:

1. Mirror is manufactured by **Gentex Corporation** (the letters **GNTX** will be etched onto the back of the mirror and the compass display window will be in the mirror glass).
2. EC mirror harness must be fully plugged into EC mirror.
3. Vehicle ignition must be in the **"ON"** position.

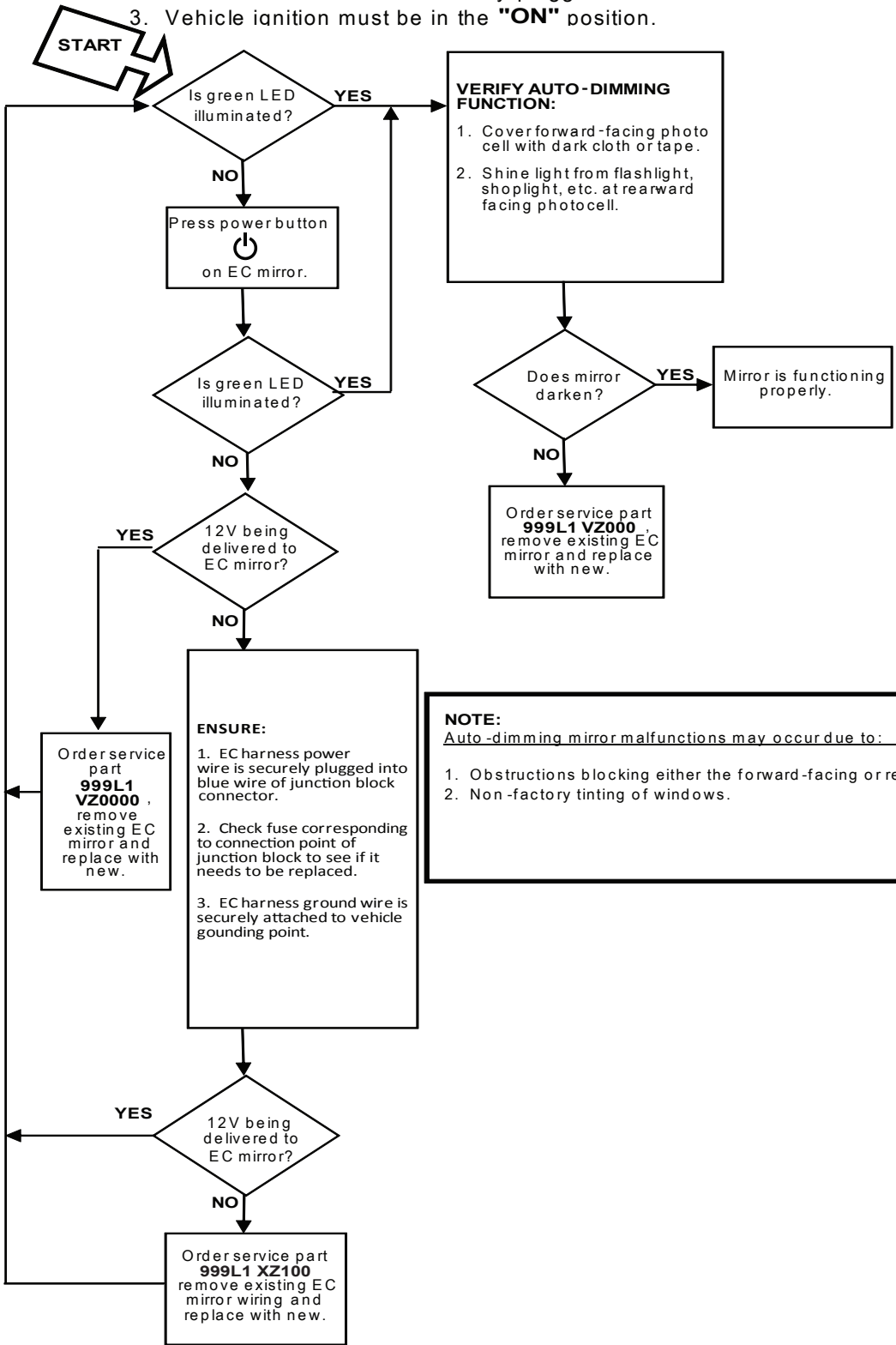

NOTE:
Auto-dimming mirror malfunctions may occur due to:

1. Obstructions blocking either the forward-facing or rearward-facing photo-cells.
2. Non-factory tinting of windows.

DIAGNOSTIC FLOW CHART:

COMPASS TROUBLE-SHOOTING GUIDE

Part Number: 999L1 XZ000

Before attempting to trouble-shoot EC mirror compass function, ensure the following:

1. Mirror is manufactured by **Gentex Corporation** (the letters **GNIX** will be etched onto the back of the mirror and the compass display window will be in the mirror glass).
2. EC mirror harness must be fully plugged into EC mirror.
3. Vehicle ignition must be in the **"ON"** position.

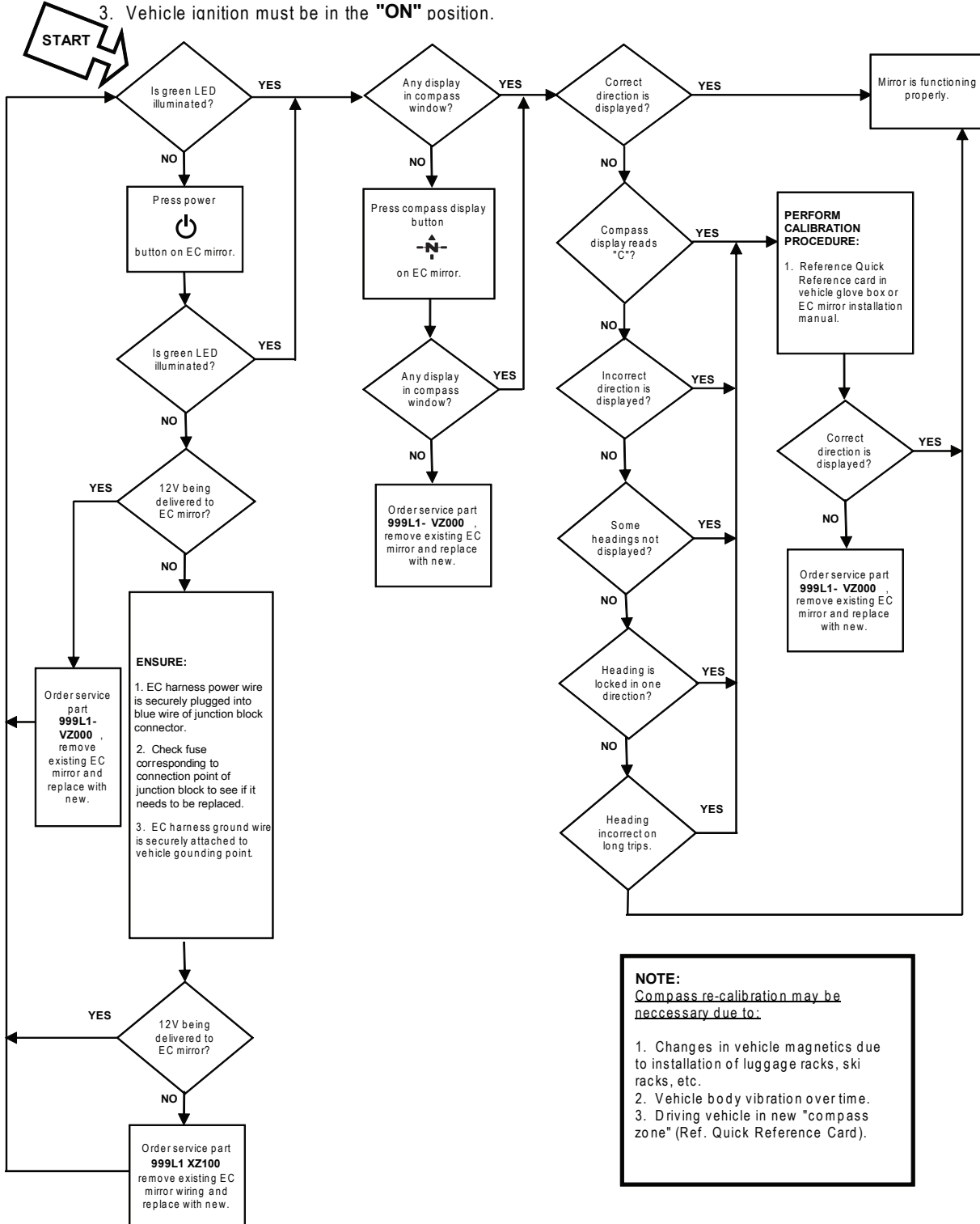

NOTE:
Compass re-calibration may be necessary due to:

1. Changes in vehicle magnetics due to installation of luggage racks, ski racks, etc.
2. Vehicle body vibration over time.
3. Driving vehicle in new "compass zone" (Ref. Quick Reference Card).

DIAGNOSTIC FLOW CHART:

HOMELINK® TROUBLE-SHOOTING GUIDE

Part Number: 999L1 XZ000

Before attempting to trouble-shoot EC mirror HomeLink® function, ensure the following:

1. Mirror is manufactured by **Gentex Corporation** (the letters **GNTX** will be etched onto the back of the mirror and the compass display window will be in the mirror glass).
2. Vehicle ignition must be in the "ON" position.
3. Vehicle ignition must be in the "ON" position.

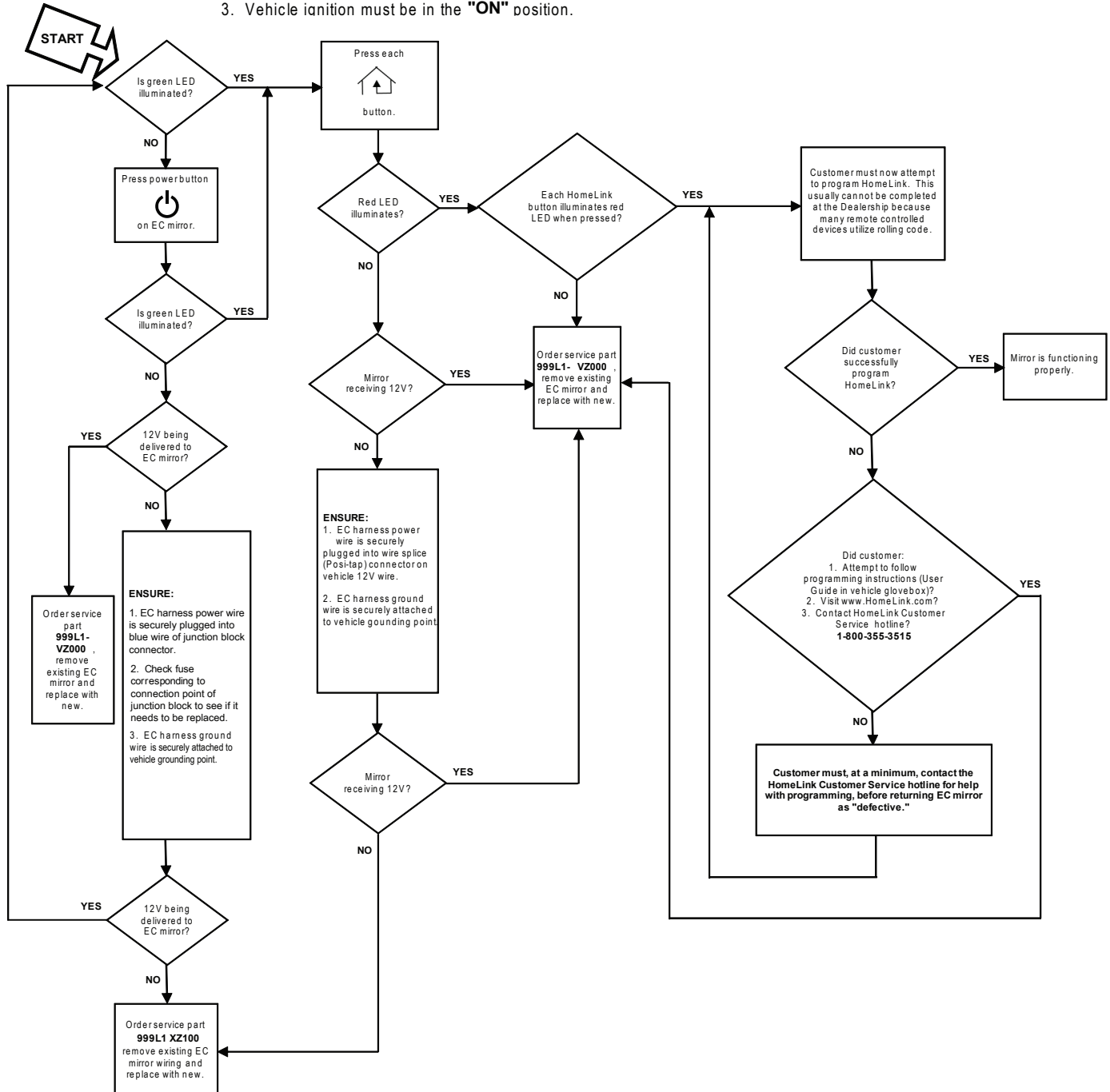

HomeLink® and the HomeLink® house are registered trademarks of Johnson Controls Inc.

ACCESSORY CONNECTOR/MIRROR SCHEMATIC:

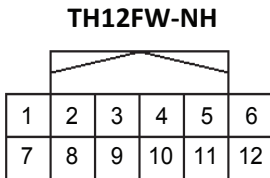
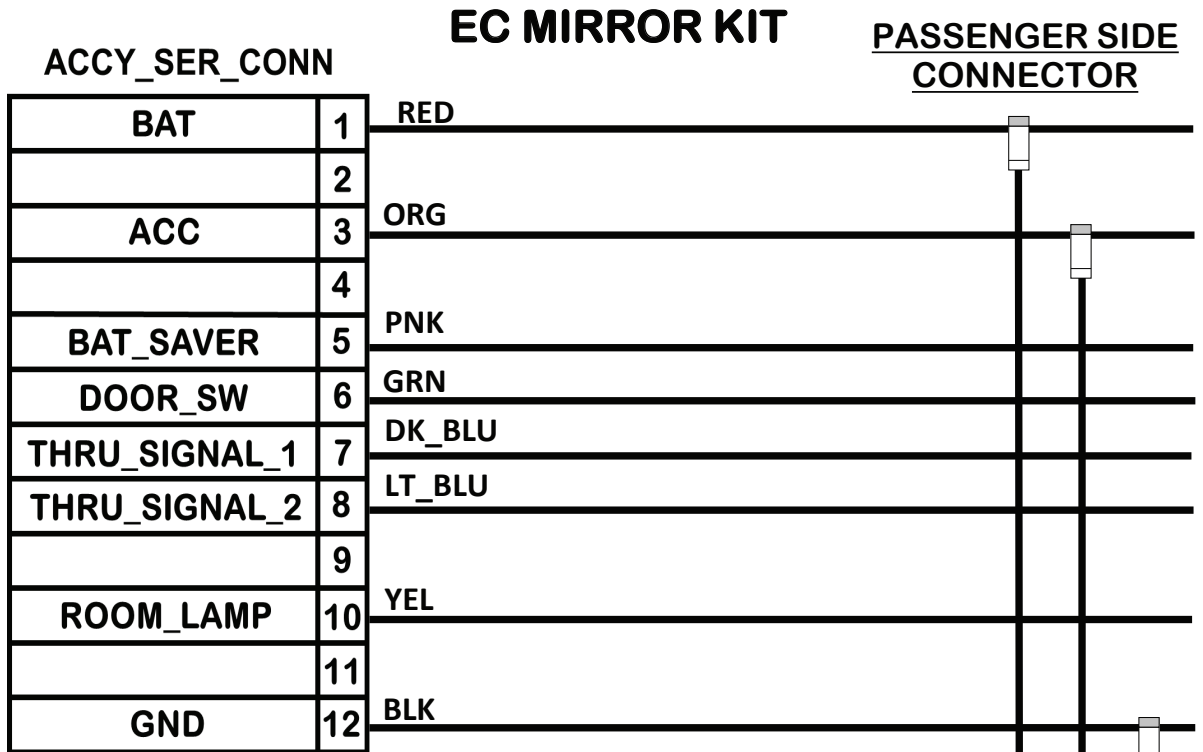

Note: Pin location is referenced looking into wire side of connector.

