



<b>PART NUMBER(S) REQUIRED FOR INSTALLATION:</b>	T99F4 5CH2C -Welcome Lighting Kit.
	(2) T99F6 4RA0A , Accessory Service Connector - not included in kit

**KIT CONTENTS:**

Item	Qty.	Part Description	Service Part Number
A	1	Control Module	Not Serviceable- Part of Kit T99F4 5CH2C
B	1	Welcome Light Bar 1.3M (RH) <b>Mounts on Vehicle LH Side</b>	
C	1	Welcome Light Bar 1.3M (LH) <b>Mounts on Vehicle RH Side</b>	
D	16	• Wire Tie 8 inch LG Black 203 x 4.7 x 1.27 mm	
E	1	• Wire Tie 12 inch LG Black 305 x 4.6 x 1.2 mm	
F	9	• Posi-Tap™ Connector	
G	5	• Foam Tape, 60 x 90 x 5 mm	
H	4	• Rubber Grommet	
J	6	• Bracket Strap	
K	6	• Bracket Base	
L	6	• Bracket Screw, M4 X 7 X 12 mm	
M	6	• Nylon Lock Nut	
N	1	• Convoluted Tubing 762 mm	
P	2	• Alchocal Wipes	
Q	1	II REPLACEMENT TEMPLATE CARD	999V2 AW000

**KIT CONTENTS: Accessory Service Connector Kit**

Item	Qty.	Part Description	Service Part Number
AAA	2	Accessory Service Connector	T99F6 4RA0A

**TOOLS REQUIRED:**

- Drill Motor
- 7 mm Drill Bit
- 7mm Wrench
- 5.5mm Wrench
- 1/4" Torque Wrench
- Bent Needle nose pliers
- Metric scale
- Pliers, Wire Cutting
- Electrical Tape
- Flashlight
- Masking Tape
- Tape measure
- Angled Trim Removal tool, nylon
- Flat Head Screwdriver
- 50% Alcohol/50% Water Solution
- Towel, Soft Non-Linting
- Scissors
- Protective Gloves

**INSTALLATION CAUTIONS:**



**CAUTION**

- Dealer installation recommended. Instructions may refer to Service Manual.
- Please read this instruction carefully before installing this product for correct installation.
- Please **DO NOT** use or install the part in ways other than what is described.
- Always use floor, seat and steering wheel protection.
- Parts utilizing adhesion as method of attachment are to be installed at surface temperature of 15-38° C
- Posi-Tap™ instructions must be specifically followed as described in Appendix A.
- Always remove vehicle parts in the sequence directed. Improper procedure can damage parts.
- Take care not to scratch or damage any component during the removal or re-installation process.
- Trim pieces found to have witness marks or broken clips **ARE NOT** to be reinstalled.
- If a problem occurs during installation, please contact Nissan dealer where you purchased the product.

**SECTION 1 - OVERVIEW**

**1.1) SYSTEM**

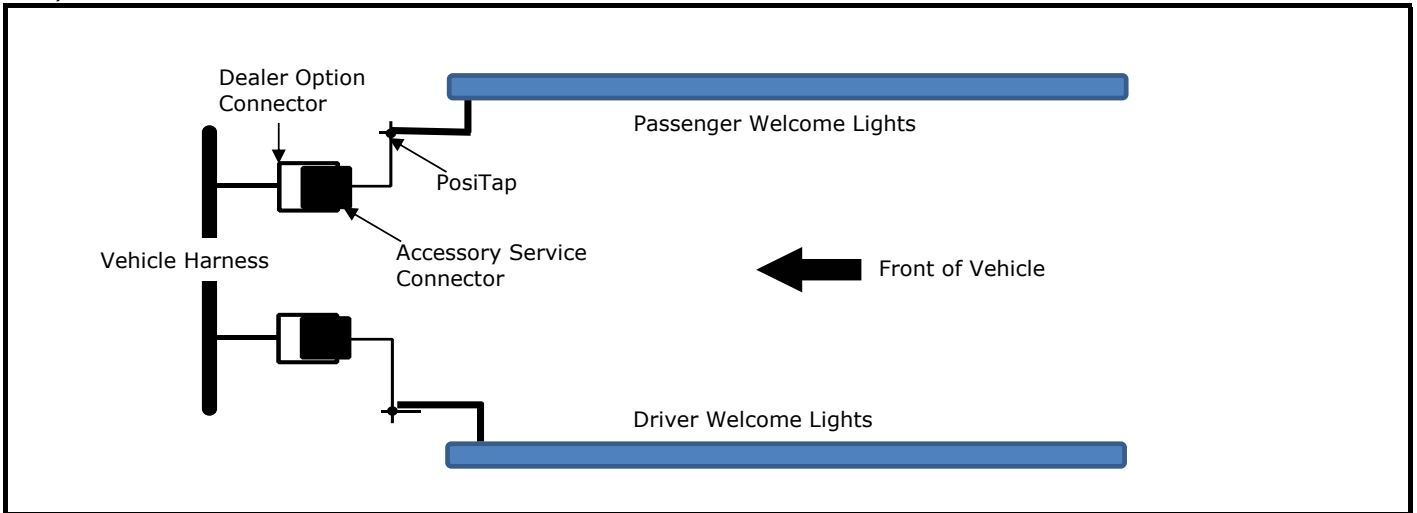

**1.2) VEHICLE**

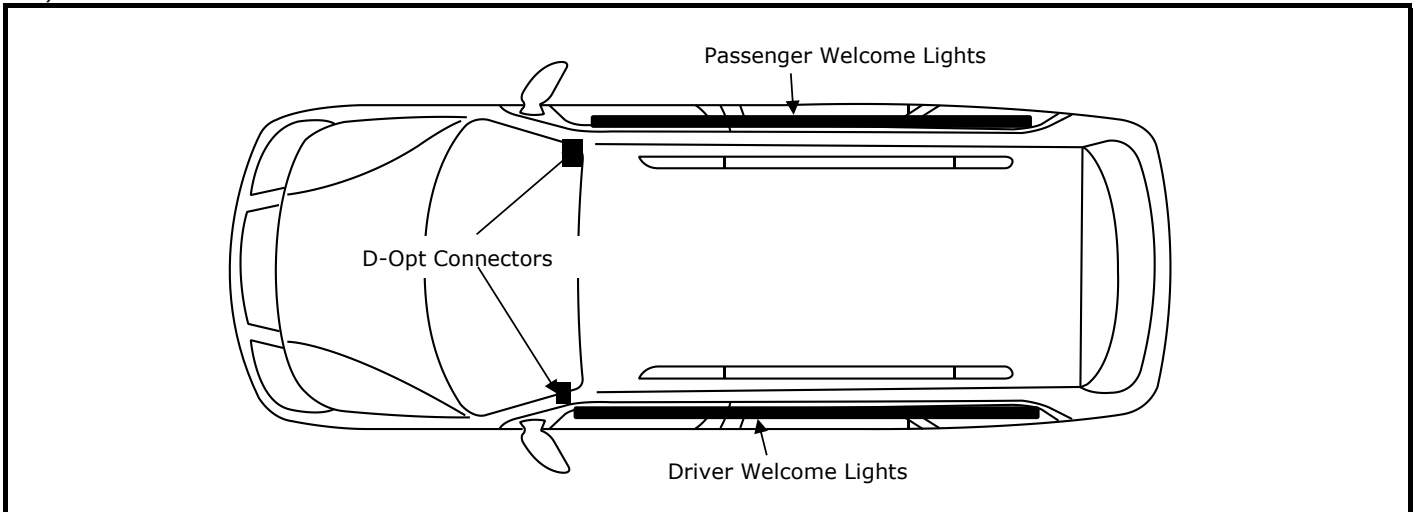

**1.3) D-OPT CONNECTOR LOCATION**

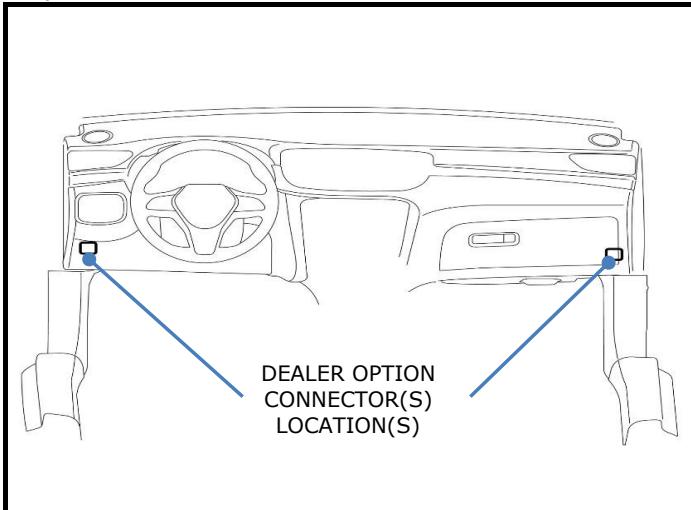

**1.4)**

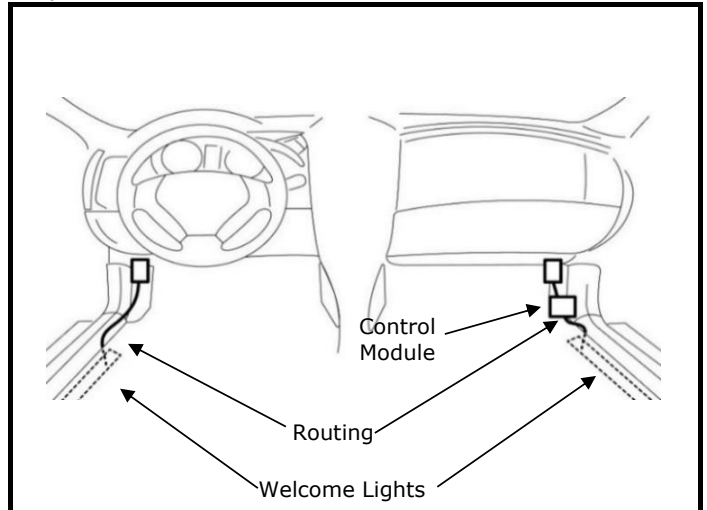



# CAUTION

• Always confirm the ignition is in the "OFF" position before changing the E.S.S. position.

• If E.S.S. is not in Customer Mode, there will be a loss of normal vehicle operation, preventing accessory function check.

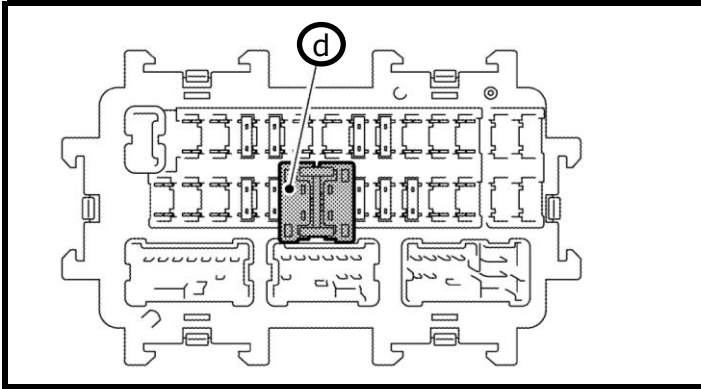

- 2.1) Check Extended Storage Switch Position
- a ) Put shift lever in "P" position for A/T and CVT or "1st" for M/T .
  - b ) Apply park brake.
  - c ) Place ignition in "OFF" mode.
  - d ) Locate Extended Storage Switch in cabin fuse block as shown.
  - e ) Confirm Extended Storage Switch is in "Customer" (In/Engaged) position.
  - f ) If ESS is not In/Engaged, then proceed to step 2.2 .

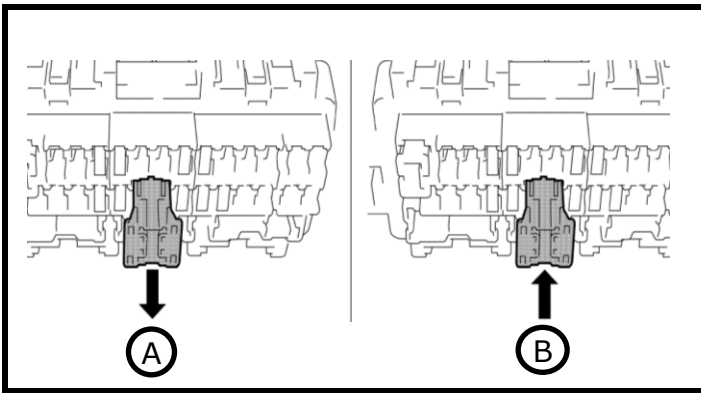

- 2.2) Changing ESS Position
- a ) To disengage Customer Mode, pull out in **A** direction as shown.
  - b ) To engage Customer Mode, press in **B** direction as shown.

Condition	Switch Position	Note
Vehicle is delivered to the dealer	Transit (OUT)	
Vehicle is being stored at the dealer	Transit (OUT)	
Vehicle is delivered to customer	Customer (IN)	

- 2.3) Record Customer Presets
- a ) Place ignition in "ON" mode.
  - b ) Record the customer radio presets and other presets as required.

Preset	1	2	3	4	5	6	7	8	9	10

## SECTION 2 - VEHICLE PREPARATION

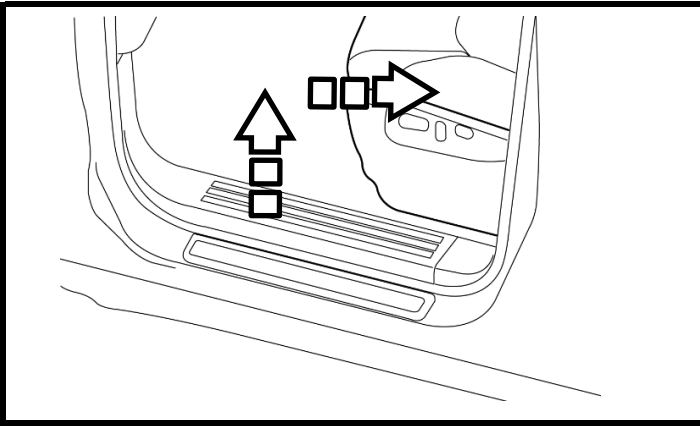

- 2.4) Move seats.  
a ) Move both front seats to full upward and rearward position.

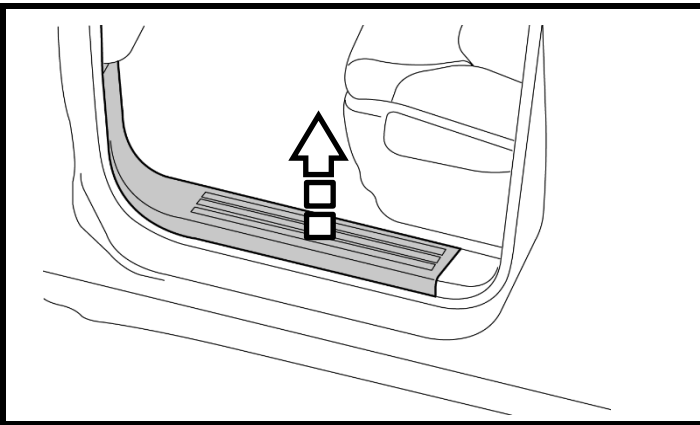

- 2.5) Remove Front LH trim.  
a ) Carefully pry off inner door sill trim panel and remove from vehicle.

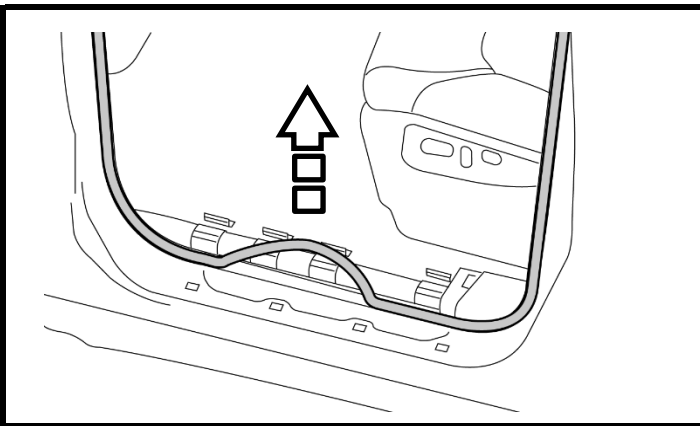

- 2.6) Remove Front LH trim  
a ) Pull up on front LH door sill weatherstrip along bottom as shown.  
b ) Move weatherstrip out of way to use trim removal tool on the second wire harness clip.

**NOTE:**  
**Do not close doors with weatherstripping pulled off edge. Reininstall to close doors.**

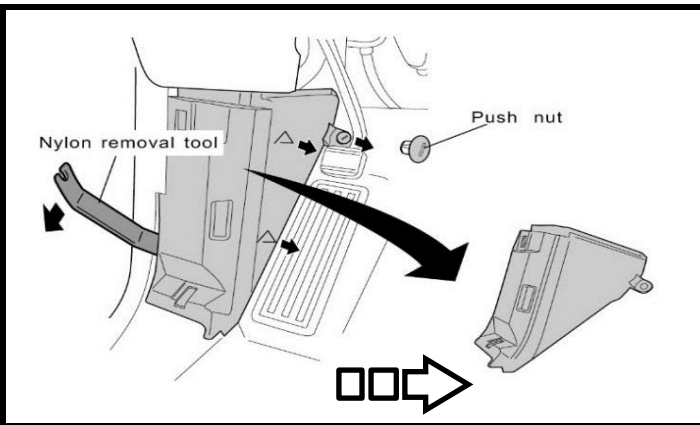

- 2.7) Remove Front LH trim  
a ) Remove trim fastener from lower kick trim by unscrewing with hand.  
Disengage lower kick trim pawl by pulling toward interior of vehicle as shown.

**Trim Fastener**



**Pawl**



- 2.8) Repeat steps 2.4-2.7 for RH (Passenger) side of vehicle.

## SECTION 2 - VEHICLE PREPARATION

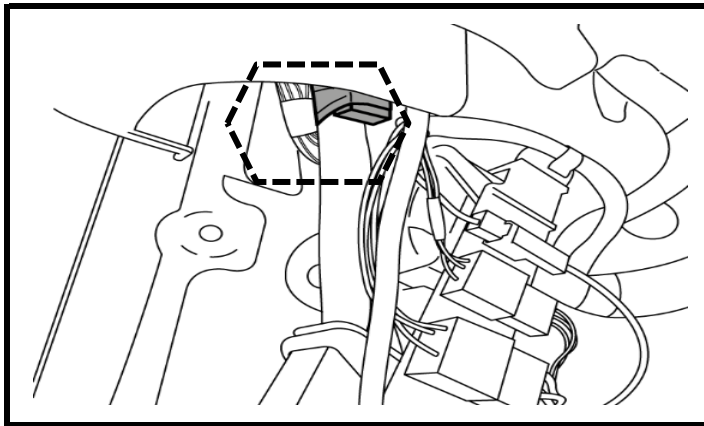

- 2.9) Locate Accessory Service Connector
- a ) Locate Accessory Service connector on LH side.
  - b ) Carefully tear or cut tape to free Dealer Option connector.

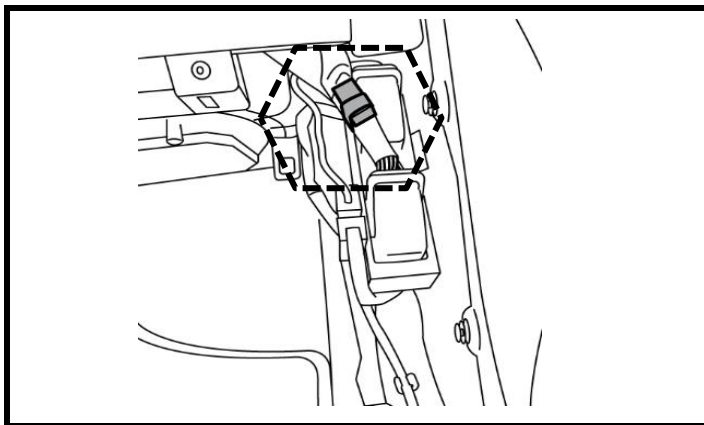

- 2.10) Locate Accessory Service Connector
- a ) Locate Accessory Service connector on RH side.
  - b ) Carefully tear or cut tape to free Dealer Option connector.

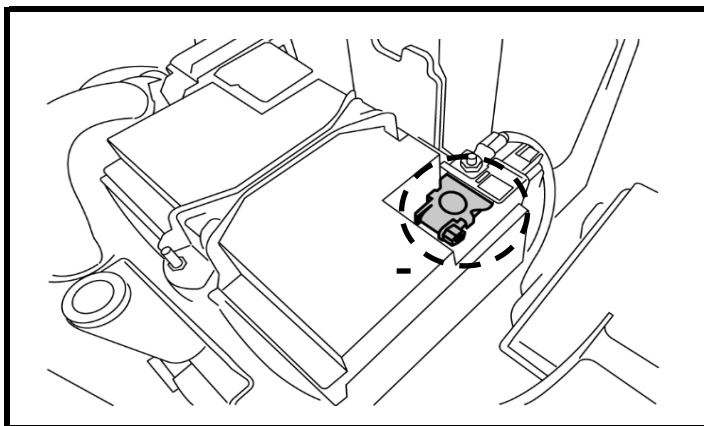

- 2.11) Disconnect battery terminal
- a ) Locate negative battery terminal.
  - b ) Loosen nut with 10mm socket.

**Battery Terminal Nut** 

**⚠ CAUTION**

- Allow 3 min after key off with doors closed for vehicle power to time out.

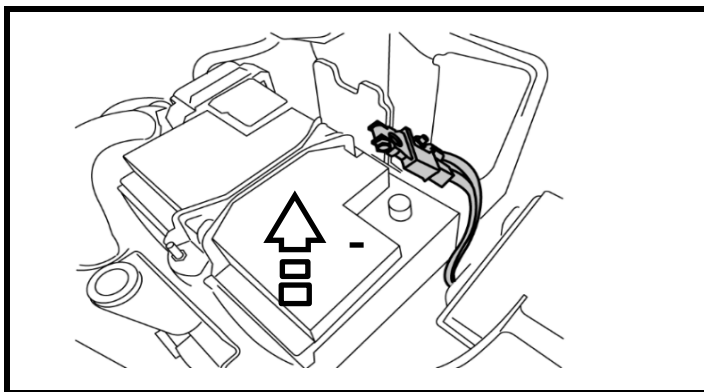

- 2.12) Disconnect battery terminal
- a ) Lift negative battery terminal off stud.
  - b ) Isolate negative battery terminal.

**⚠ CAUTION**

- Allow 3 min after negative terminal disconnect before separating any electrical connectors.

## SECTION 2 - VEHICLE PREPARATION

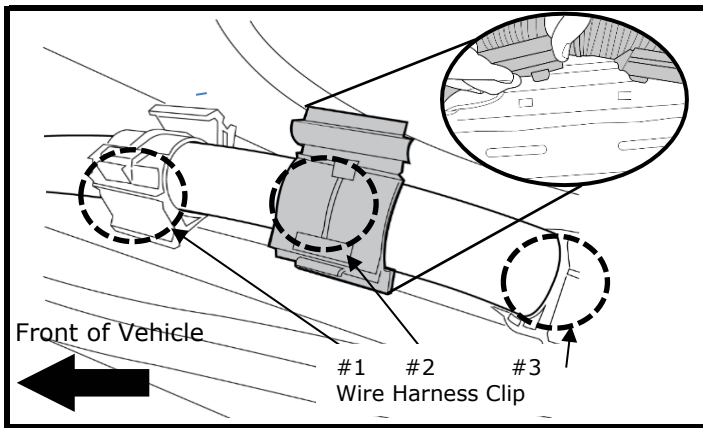

- 2.13) Prepare to drill feed through hole in wire harness clip
- Unclip and remove second wire harness clip from vehicle.
  - Move to a flat surface, open and turn clip over.

Harness Clips

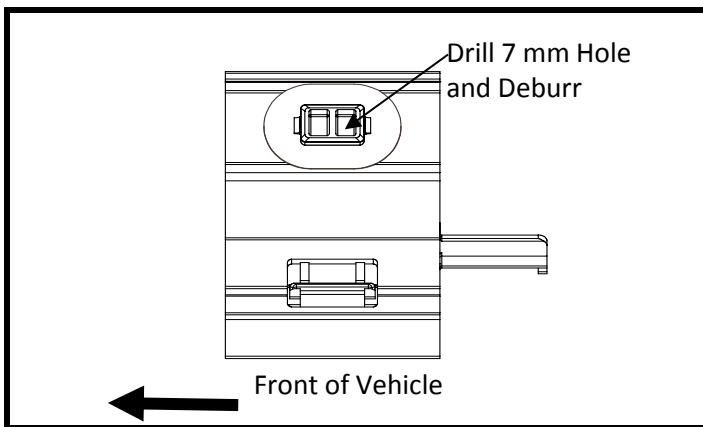

- 2.14) Drill hole in front wire harness clip to pass harness through
- Drill 7 mm hole through the bottom of the clip as shown.
  - Deburr and Clean hole on the inner surface of the wire clip

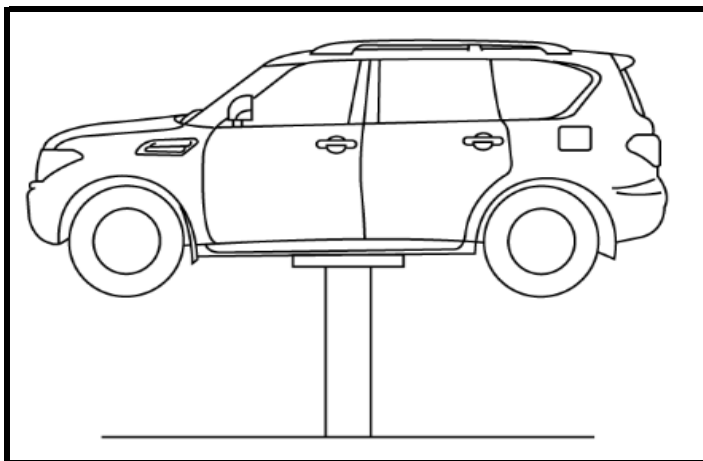

- 2.15) Repeat steps 2.13-2.14 for RH (Passenger) side of vehicle.
- 2.16) Lift Vehicle to prepare for Light Bar installation
- Locate lift points, set hoist arms and raise vehicle to necessary work height.

### WARNING

- Always use proper lift points as specified in Service Manual Section: GI
- Be sure vehicle is secure on locks before proceeding underneath.
- Never get under the vehicle when it is supported only by the jack. Always use safety stands.

**SECTION 2 - VEHICLE PREPARATION**

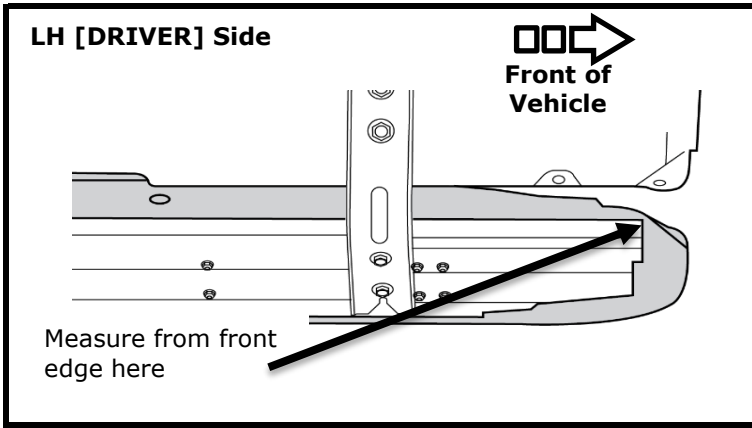

- 2.17) Prepare Step for Welcome Light Bar install
- Wipe the full length of the Inside edge of the LH [Driver's] step shown.

**2.18) Mark step reference lines to locate drill hole locations for Welcome Light Brackets**

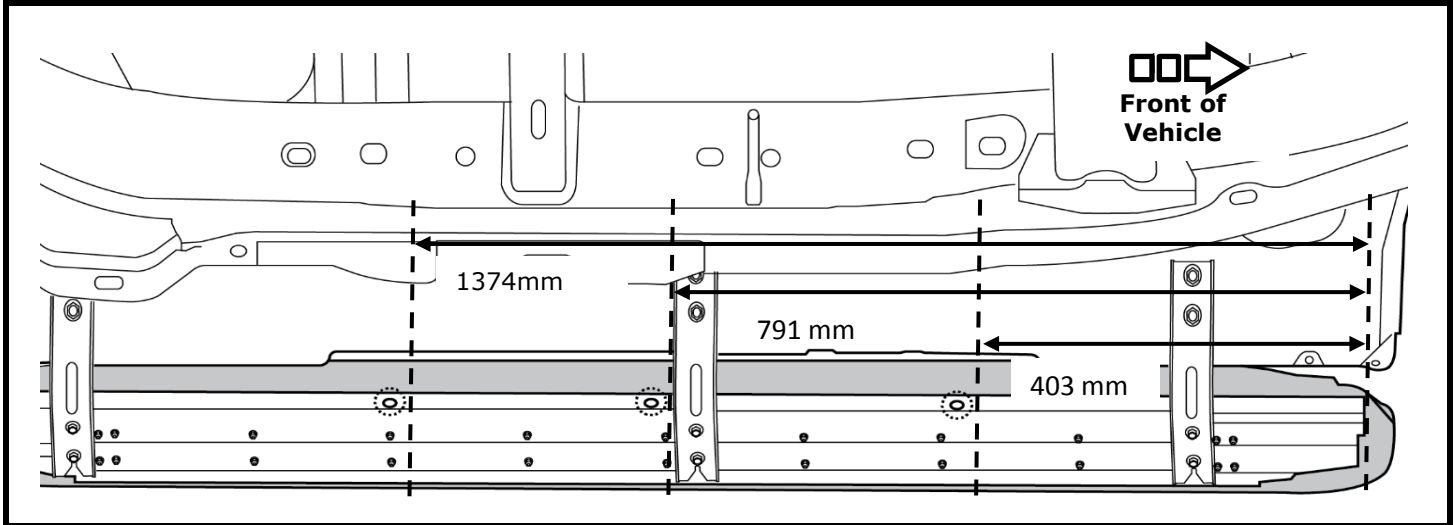

- Use tape measure to mark centerlines along step edge toward centerline of vehicle as shown at 403, 791, 1374 mm. Measure from front edge of step as shown on insert.
- Repeat marking RH [Passengers] side.
- Final drilled hole locations.

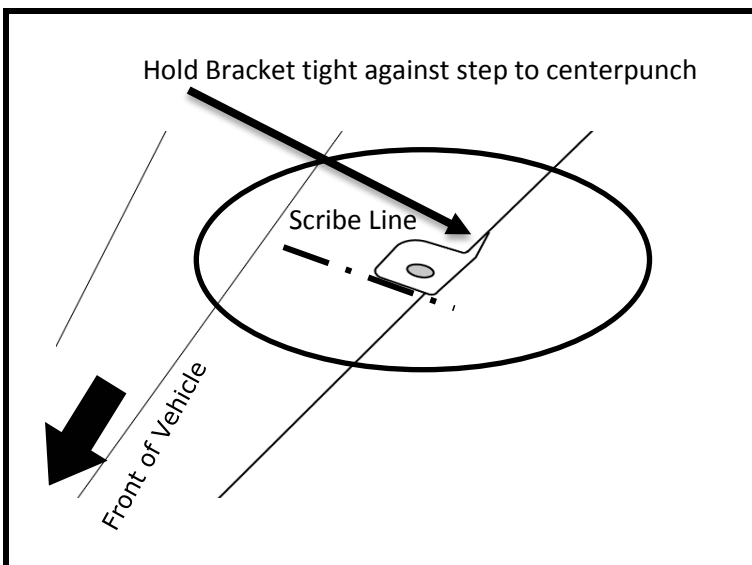

- 2.19) Drill LH step hole locations for Welcome Light
- Use top half of bracket to mark centerline of hole on three (3) scribe marks on the step rail.
  - Hold bracket so the front edge of the bracket is behind the marked line [bracket to rear of vehicle] and center punch bracket hole location.
  - Set drill stop to 6.0mm depth.
  - Drill 5.0 mm holes in each of the six (6) locations, deburr.

2.20) Repeat steps 2.17-2.19 for RH (Passenger) side of vehicle.



## SECTION 3 - Install

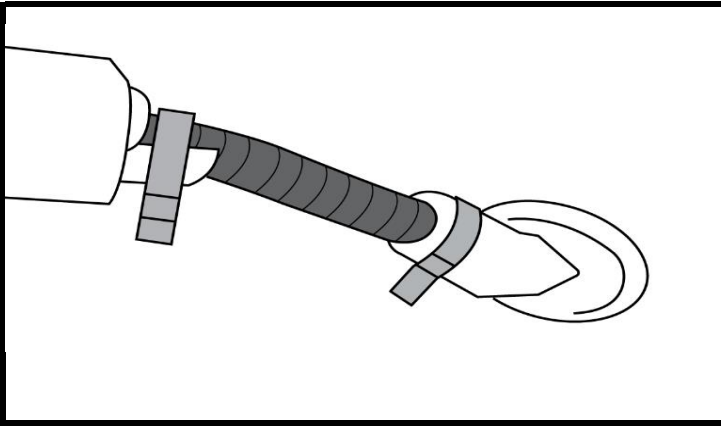

- 3.1) Prep both light bars for mounting.
  - a) Cut two (2) 80 mm pieces of convoluted tubing and slide convoluted tubing over harness and secure both end with tie strap.
  - b) Slide one of the grommets over wire and tie strap to convolute tubing.

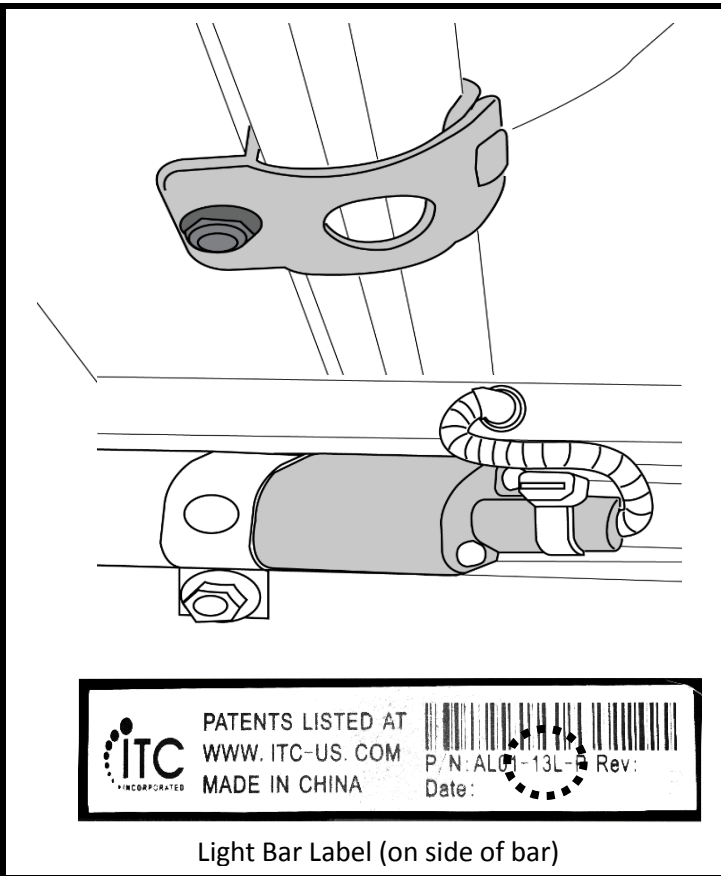

- 3.2) Mount Light bars to Step
  - a) Install three (3) bolts in holes on drivers side step.
  - b) Assemble both parts of bracket on wire end of light bar and use bolt in step and nut to attach bar to step.
  - c) Align end cap of light bar up to edge of the first mounting bracket.
  - d) Tighten bolts using 7.0mm wrench and 5.5mm wrench to 2-3 Nm.
  - e) Repeat for remaining two bolts.

- 3.3) Remove first drain hole plug in sill.

### Caution:

**Mount Bar marked 13R on the LH (Driver's side) of the vehicle. Mount Bar marked 13L on the RH (Passengers side) of the vehicle. (Bar Label will face toward outside vehicle.)**

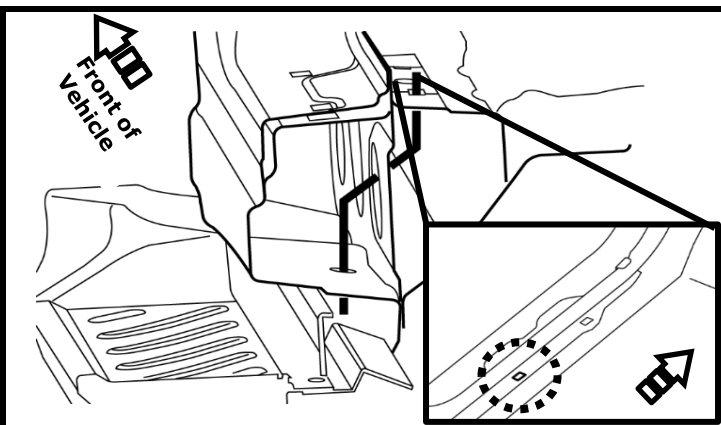

- 3.4) Route Harness to inside the vehicle
  - a) Feed tie strap from 1<sup>st</sup> drain hole in outer sill in front of vehicle to the second wire harness clip hole exposed by removing clip. Tape light bar harness to tie strap and feed through to inside vehicle.
- 3.5) Repeat steps 3.1 - 3.4 for RH (Passenger) side of vehicle.

## SECTION 3 - Install

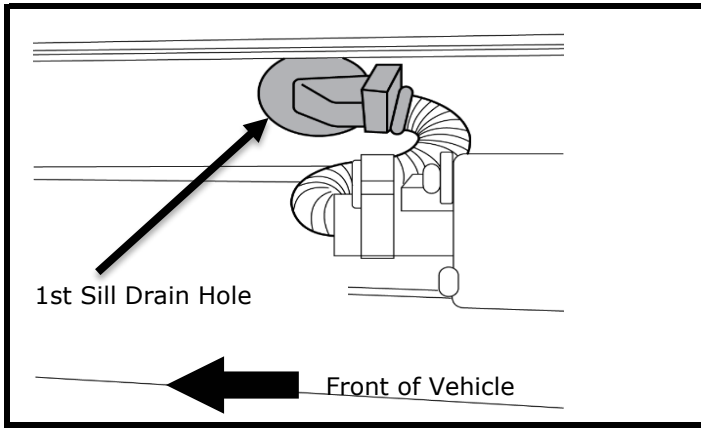

- 3.6) Harness routing inside vehicle.
- After harness is routed to inside sill, ensure outside grommet is seated.

**Note:**

**Prior to pulling harness upward, make sure harness is not wrapped, caught, or trapped by the bracket or step rail.**

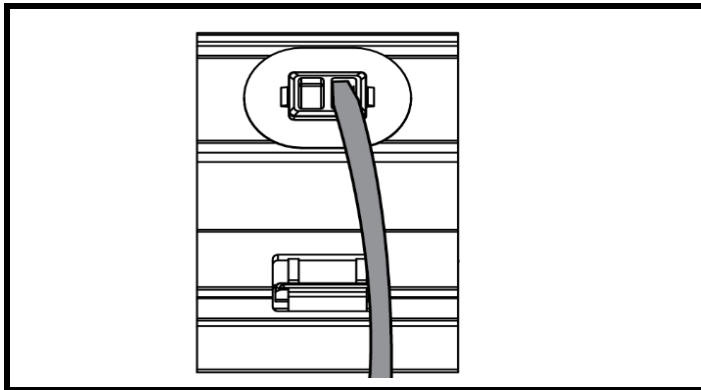

- 3.7) Harness Inside Vehicle

- Feed harness through hole s drilled through wire harness clip

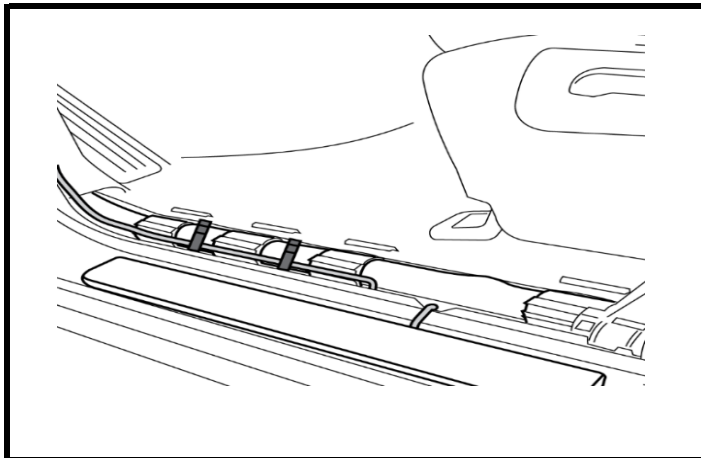

- 3.8) Harness Routing

- Reinstall both wire harness clip and route wire along wire harness bundle.

**Note:**

**Ensure black foam rubber seal is correctly positioned under clip prior to reinstallation.**

**Note:**

**Install tie straps every 100 - 200 mm. Be careful not to secure tie straps over the drain tube.**

- 3.9) Repeat steps 3.4 - 3.8 for RH (Passenger) side of vehicle.



## CAUTION

The Accessory Service Connector (AAA) is for use only with Genuine Nissan or Nissan-Approved accessories. Nissan/Infiniti is not liable for loss or damage due to improper installation or installation of non-Genuine or non-Approved accessories.

**Accessory Service Connector**



AAA

- 4.1) Connect Accessory Service Connector
  - a) Accessory Service Connector (AAA) pin-out is shown.
  - b) For direction on how to connect Posi-Tap refer to Appendix A.
  - c) For additional circuit information refer to Appendix B.

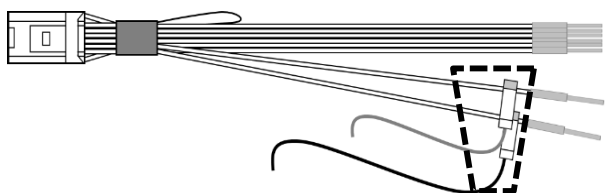

- 4.2) Installing Posi-Tap™ on RH (Passengers side) Accessory Service Harness.
  - a) Black wire from Control Module to Black wire on Accessory Service Connector Harness.
  - b) Pink wire from Control Module to Pink wire on Accessory Service Connector Harness.
  - c) White wire from Control Module to White wire on Accessory Service Connector Harness.
  - d) Yellow wire from Control Module to Yellow wire on Accessory Service Connector Harness.
  - e) Grey wire from the Control Module to Grey wire on the Accessory Service Connector Harness.
  - f) Black wire from LED Harness to Black wire on the Controller Module Harness.
  - g) Red wire from LED Harness to Grey wire on Controller Module Harness.

**Install 4 - ASC CONNECTION & FUNCTION CHECK**

**Passenger's Side**

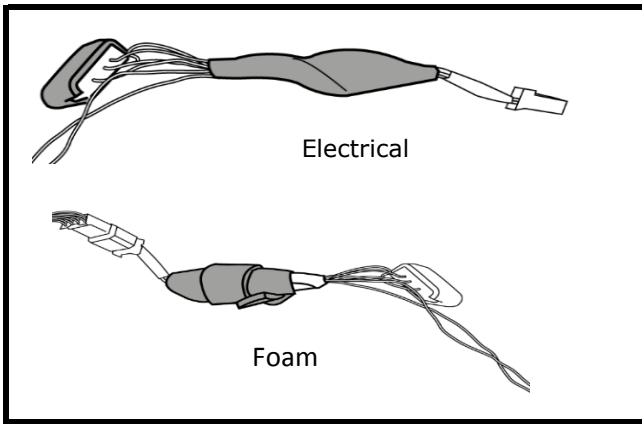

- 4.3) Wrap Posi-Taps™ attached to the Accessory connector harness and with electrical tape as shown. Do not wrap unused wires.
- a) Wrap posi taps with electrical tape.
  - b) Wrap electrical tape bundle with foam tape.

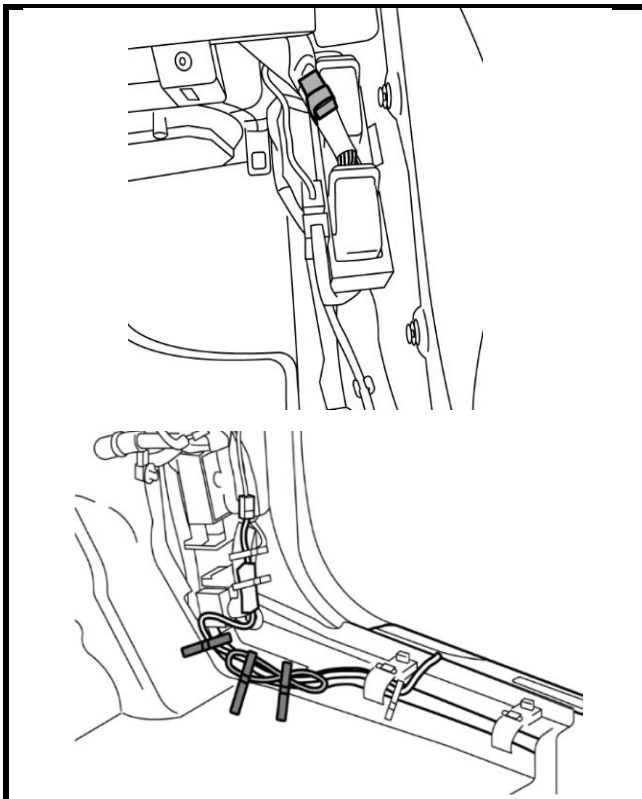

- 4.4) Plug Accessory Connector Harness into vehicle connector plug on RH (Passenger's side).
- a) Posi-Tap™ the module harness and the light bar harness to ACS Harness.
  - b) Dress excess harness as and tie strap as shown.

**NOTE:**

**Recommended spacing for cable ties is 100mm to 120mm. Position cable ties as shown.**

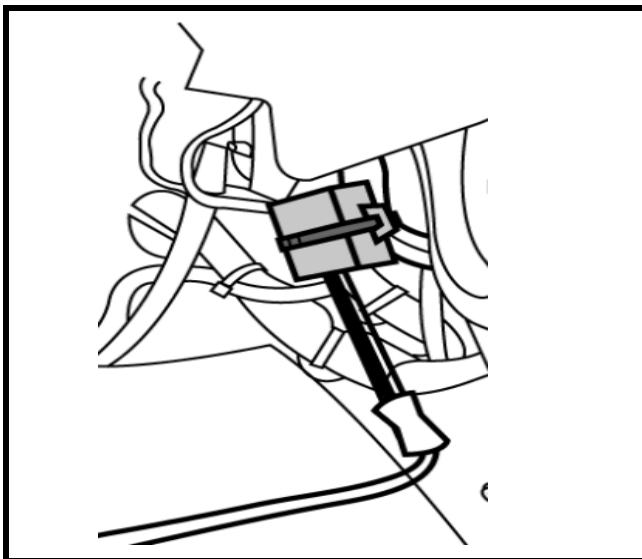

- 4.5) Mount Control Module
- a) Wrap control module in foam tape.
  - b) Tie Strap module to harness as shown.
- Note:**  
**Use two 8 inch tie straps to make one large tie strap or one 12 inch tie strap if available to secure module.**

# CAUTION

The Accessory Service Connector (AAA) is for use only with Genuine Nissan or Nissan-Approved accessories. Nissan/Infiniti is not liable for loss or damage due to improper installation or installation of non-Genuine or non-Approved accessories.

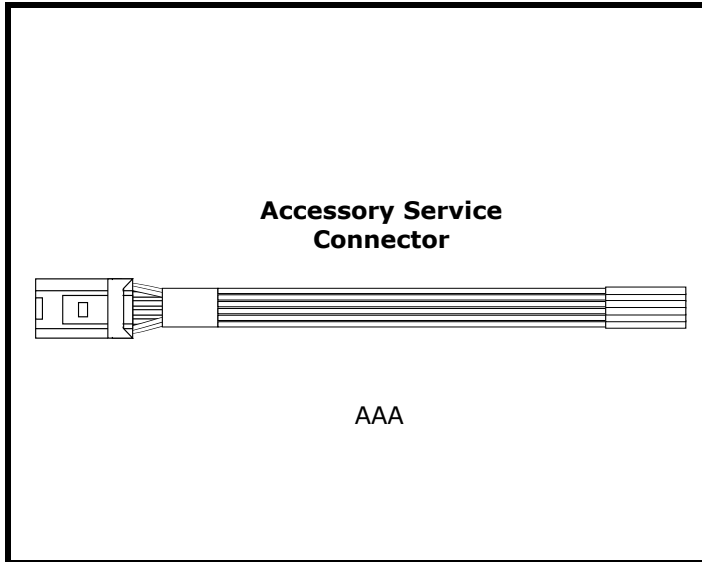

- 4.6) Connect Accessory Service Connector Harness
- a) Accessory Service Connector harness (AAA) pin-out is shown.
  - b) For direction on how to connect Posi-Tap refer to Appendix A.
  - c) For additional circuit information refer to Appendix B.

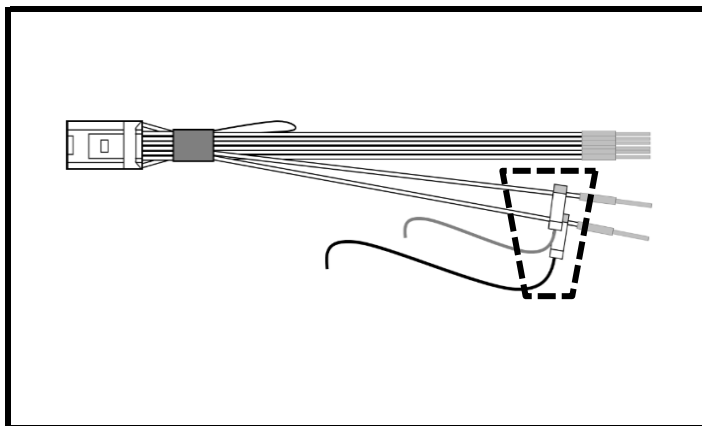

- 4.7) Installing Posi-Tap™ on LH (Driver's Side) Accessory Service Connector.
- a) Black wire from LED Harness to Black wire on Accessory Service Connector Harness.
  - b) Red wire from the LED Harness to the Grey wire on the Accessory Service Connector Harness.

**Posi Tap (F)**



## SECTION 4 - ASC CONNECTION & FUNCTION CHECK

### DRIVER'S SIDE

- 4.8) Wrap Posi-Taps™ attached to the Accessory connector harness and with electrical tape as shown. Do not wrap unused wires.
- a ) Wrap posi taps with electrical tape.
  - b) Wrap electrical tape bundle with foam tape.

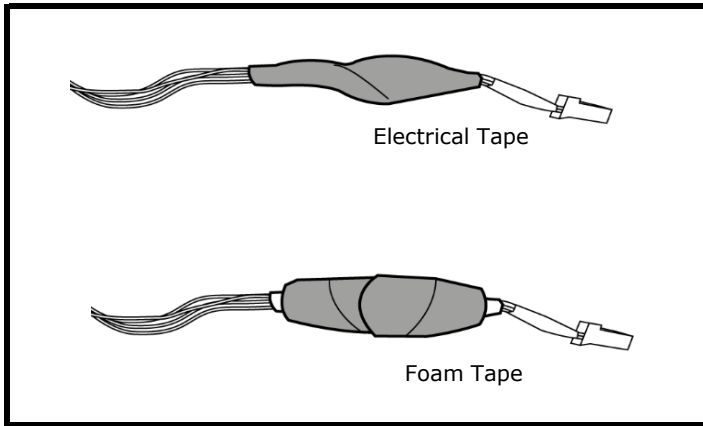

- 4.9) Plug Accessory Connector Harness into vehicle connector plug on the LH (Driver's side).
- a) Posi Tap the module harness and the light bar harness to ACS.
  - b) Dress excess harness as and tie strap as shown.

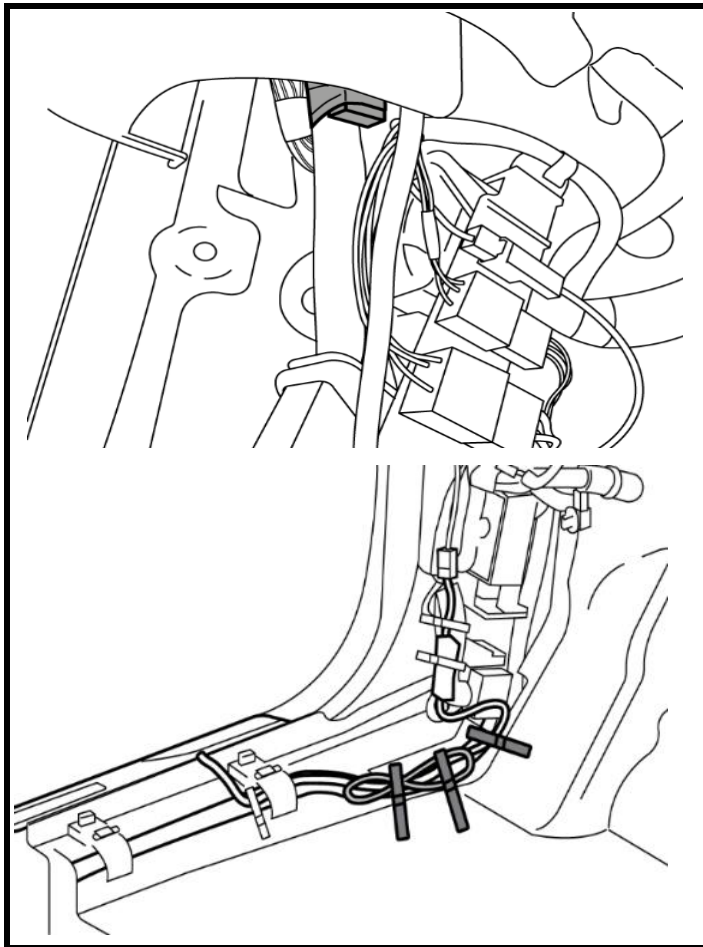

## SECTION 5 - FINAL

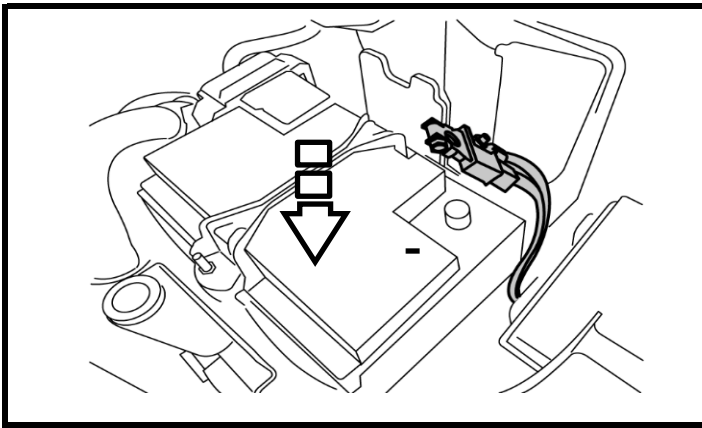

- 5.1) Electrical function check
- Close all doors.
  - Re-connect negative battery cable.
  - Use key unlock and lock on key fob and check if lights follow room lamp operation.

If NG, check harness routing, connections, and module to identify root cause.



## CAUTION

**When diagnosing electrical system problems, first disconnect the accessory connectors and note effect on vehicle system. Continue the investigation with the accessory connectors disconnected. Reconnect when the investigation is complete.**

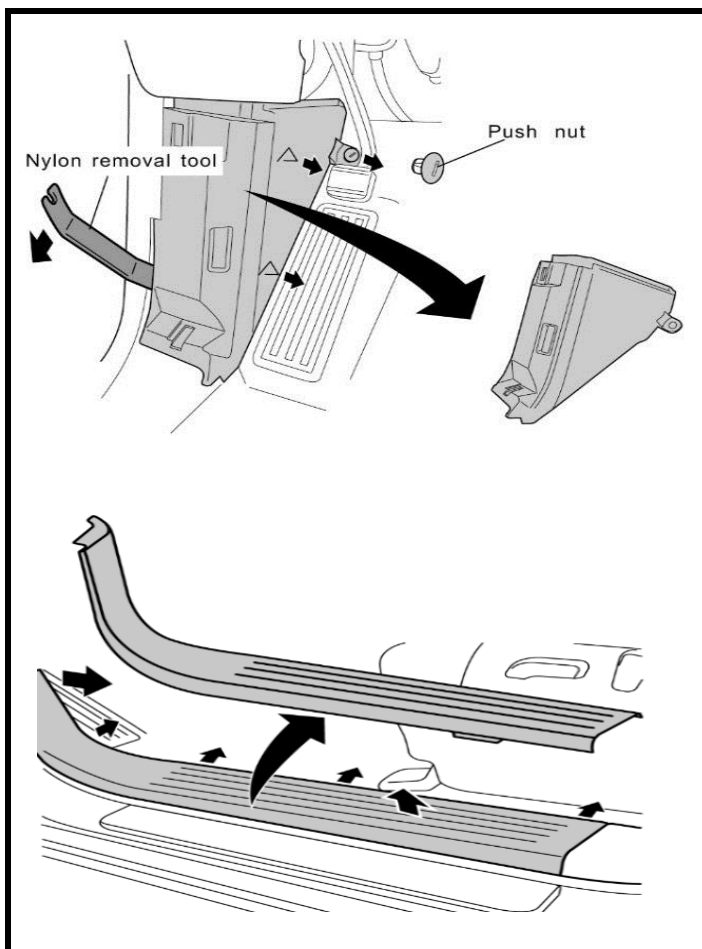

- 5.2) Reinstall interior trim removed in section 2 for the LH (Driver's) and RH (Passengers) side of the vehicle.

### NOTE:

**Be sure all clips are properly aligned. Be careful not to damage any clips on the panels during reinstallation.**

 **CAUTION**

**Take care not to scratch or damage any component during the removal or re-installation process. Trim pieces found to have witness marks or broken clips should be replaced with new parts.**

## 5.3) Complete checklist:

- Tighten battery terminal nut to 5 N-m.
- Verify re-installed trim parts for proper fit (no gap, waviness, etc.), particularly the door sill weather
- Verify all windows and sunroof (if equipped), one touch operation and perform the reset procedure if necessary. Refer to the vehicle Service Manual for more details.
- Re-program radio presets and other vehicle settings to the recorded settings if necessary.
- If this vehicle will be returned to a dealer lot or showroom for an extended period of time, be sure the Extended Storage Switch is placed in the Transit position. See step 2.2.a)
- Remove all tools, templates, and other debris from interior of vehicle.
- Verify vehicle headliner, seat, steering wheel, center console, carpet, etc. are not soiled.
- Verify interior and exterior are not damaged.

## 5.4) Accessory Final checklist:

- Close all doors.
- Using the keyless entry fob, press the door unlock.
- Verify the security lighting turns on and off with the dome lamp in the car.
- Enter the car and press the door unlock and then start the car.
- Verify the welcome lamps turn off when the car starts.
- With the car running, shifter in park, open the door and verify the lights remain off.
- Turn off car and open door again and verify welcome lights and dome lamp
- Unlock the doors, wait and then lock the doors. The welcome lighting should turn off with the dome lamp.



## APPENDIX A - POSI-TAP PROCEDURE

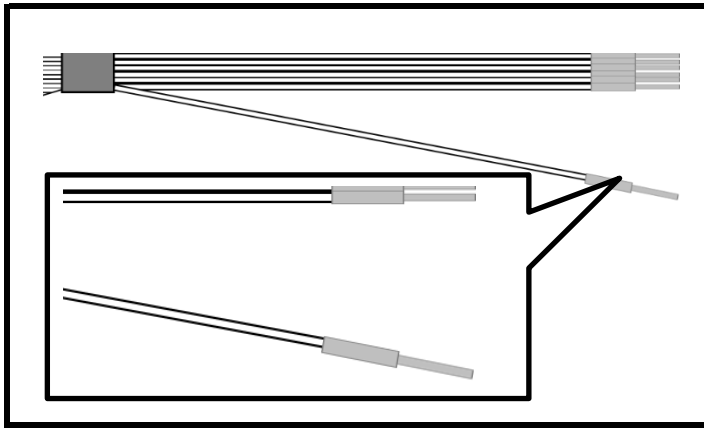

### A.1) Installing Posi-Tap™ on Accessory Service Connector (AAA)

- a ) Identify and confirm ASC wire to be tapped. Check color as well as connector location.
- b ) Separate wire from rest of bundle.

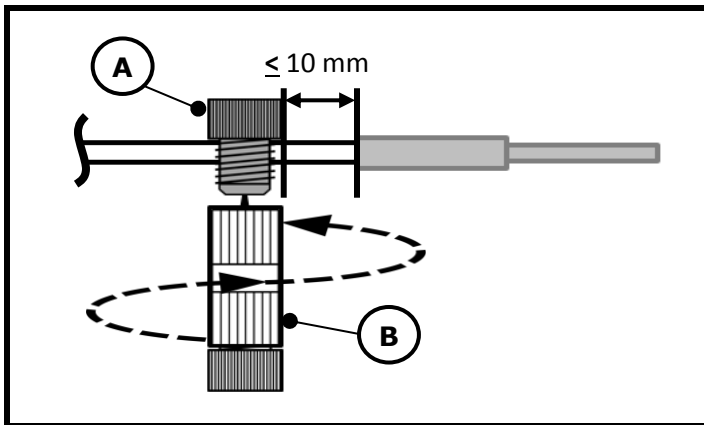

### A.2) Installing Posi-Tap™ on ASC (AAA)

- a ) Remove pierce cap (A) gray side from tap
- b ) Slide cap around single wire to be tapped
- c ) Position cap  $\leq 10$  mm away from heat shrink end of connector.
- d ) Turn tap (B) clockwise until finger "tight". Then secure to cap (A) with another  $\frac{1}{4}$  turn.



**CAUTION**

**Do not overtighten Posi-Tap, it may damage wire**

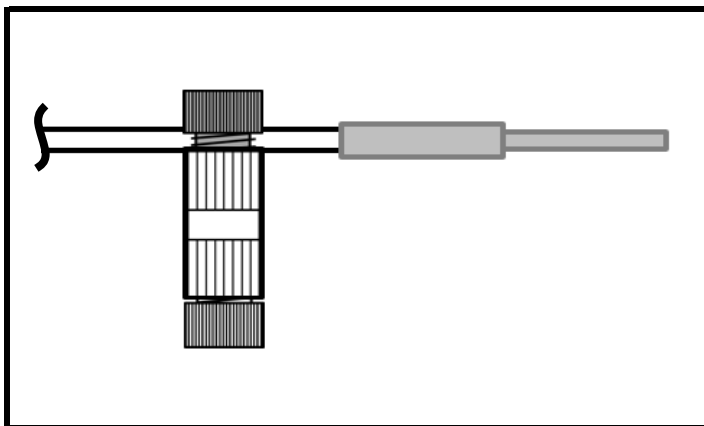

### A.3) Installing Posi-Tap™ on ASC (AAA)

- a ) Inspect Posi-Tap™ to ensure correct installation.
- b ) Wire jacket should be crushed enough to maintain pressure.
- c ) Confirm tap cap gap is straight and evenly spaced around perimeter.

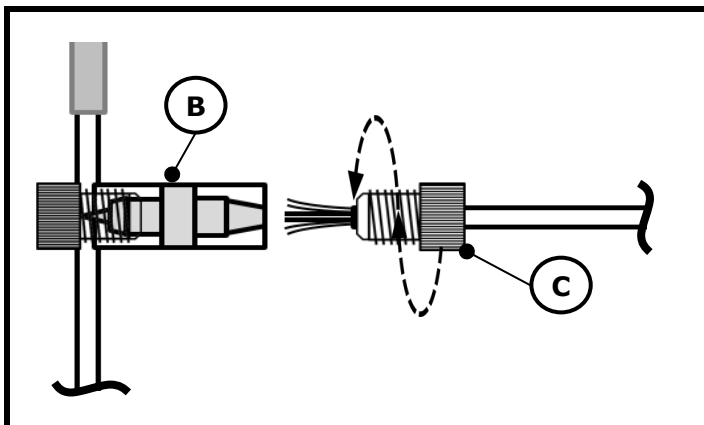

### A.4) Installing Accessory wire into Posi-Tap™

- a ) Remove tap bottom (C) red side from tap body (B).
- b ) Remove the pre cut insulation from correct Accessory wire.
- c ) Insert wire through tap bottom (C) opening.
- d ) Fan out individual wire strands as shown.
- e ) Insert wire into tap body until it bottoms out.
- f ) Turn tap bottom (C) clockwise until finger "tight". Then secure to tap body (B) with another  $\frac{1}{4}$  turn.

## APPENDIX A - POSI-TAP PROCEDURE

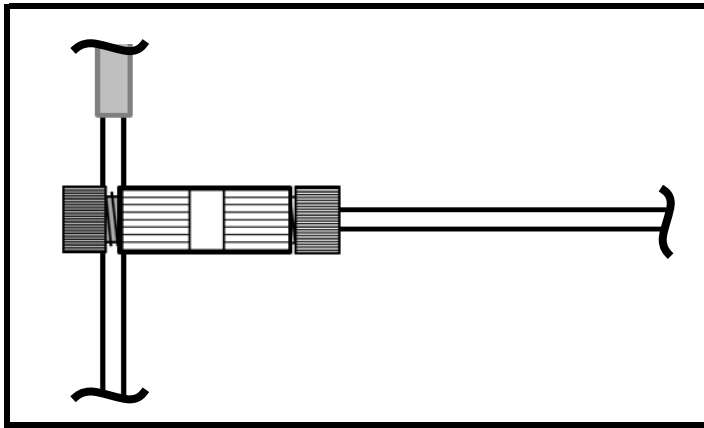

### A.5) Installing accessory wire into Posi-Tap™

- a ) Confirm tap bottom gap is straight and evenly spaced around perimeter
- b ) Gently pull on wire to confirm secure connection.

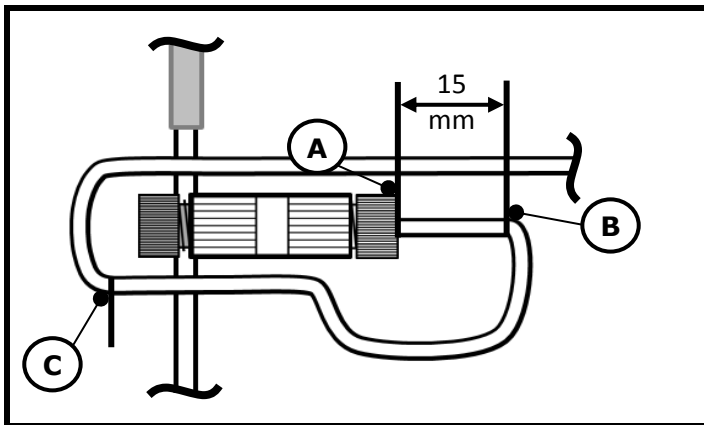

### A.6) Accessory wire strain relief

- a ) Measure  $\geq 15$  mm from point (A).
- b ) Gently form a loop at point (B) and bend back up towards Posi-Tap™ (bend radius  $\geq 10$ mm).
- c ) Gently form a loop at point (C) and bend back over top of Posi-Tap™ and down opposite side (bend radius  $\geq 10$ mm).

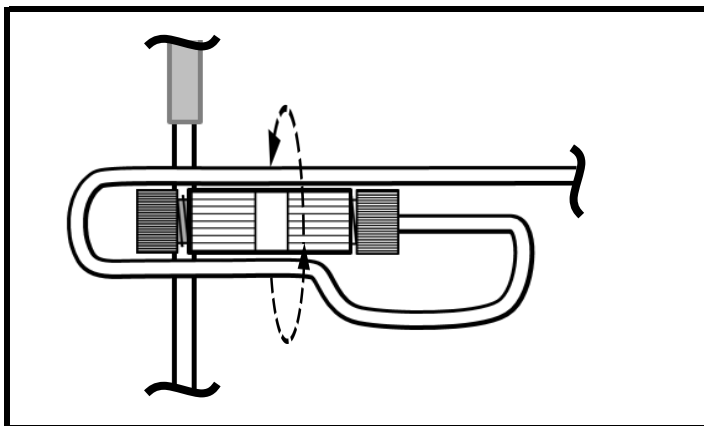

### A.7) Accessory wire strain relief

- a ) Secure accessory wire strain relief to tap body with electrical tape ( $\geq 2$  revolutions).

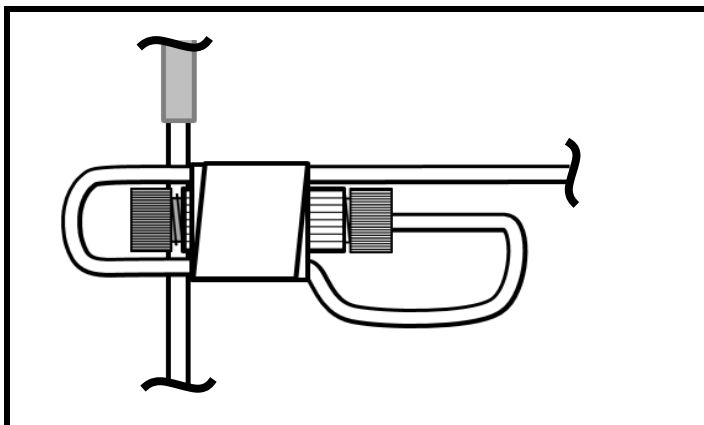

### A.8) Accessory wire strain relief

- a ) Once accessory wire strain relief is taped to tap body, it should look as shown.

### A.9) Installing Posi-Tap™ on ASC (AAA)

- a ) Repeat steps A.1 - A.8 for all other wires requiring a Posi-Tap™.

## APPENDIX A - POSI-TAP PROCEDURE

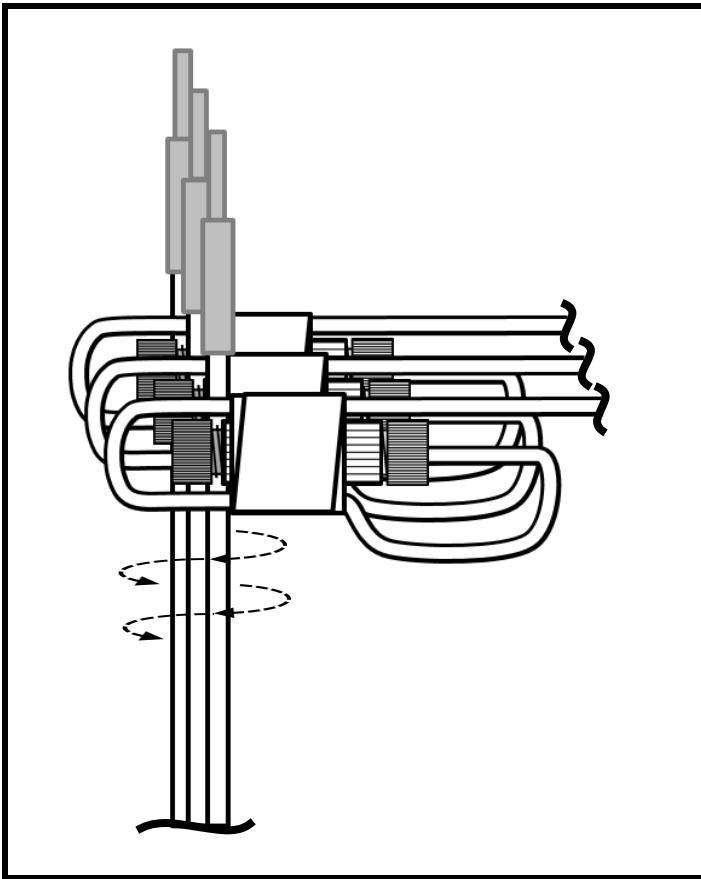

- A.10) Securing multiple Posi-Taps™ together
- a ) Stack Posi-Taps™ in slightly staggered fashion as shown.
  - b ) Secure tapped circuits together with electrical tape ( $\geq 2$  revolutions).

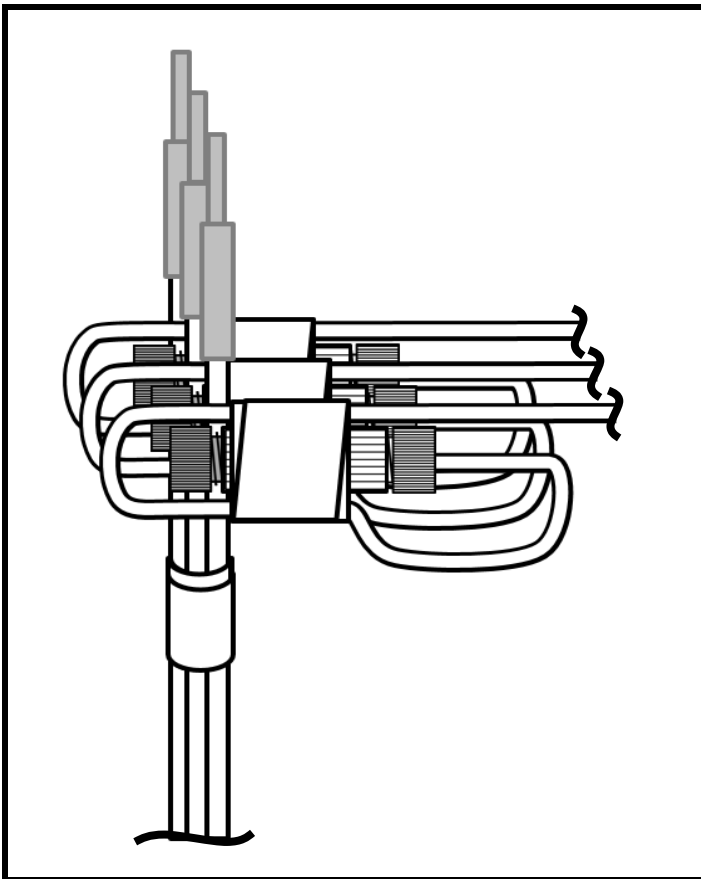

- A.11) Securing multiple Posi-Taps™ together
- a ) Once tapped circuits are secured together with electrical tape they should look as shown.

## APPENDIX A - POSI-TAP PROCEDURE

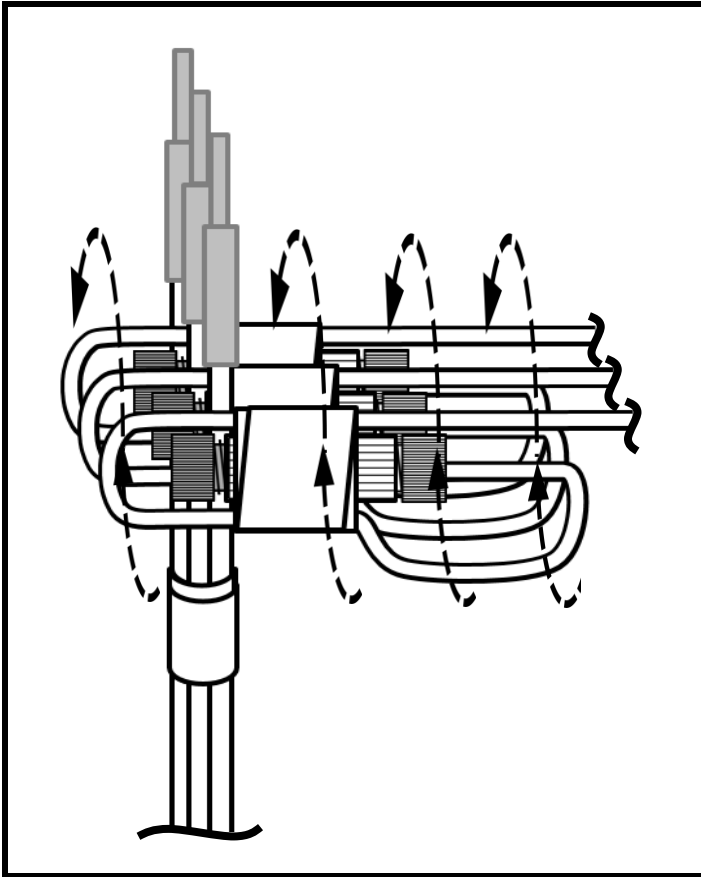

- A.12) Securing multiple Posi-Taps™ together  
a ) Secure Posi-Taps™ together with electrical tape ( $\geq 4$  revolutions).

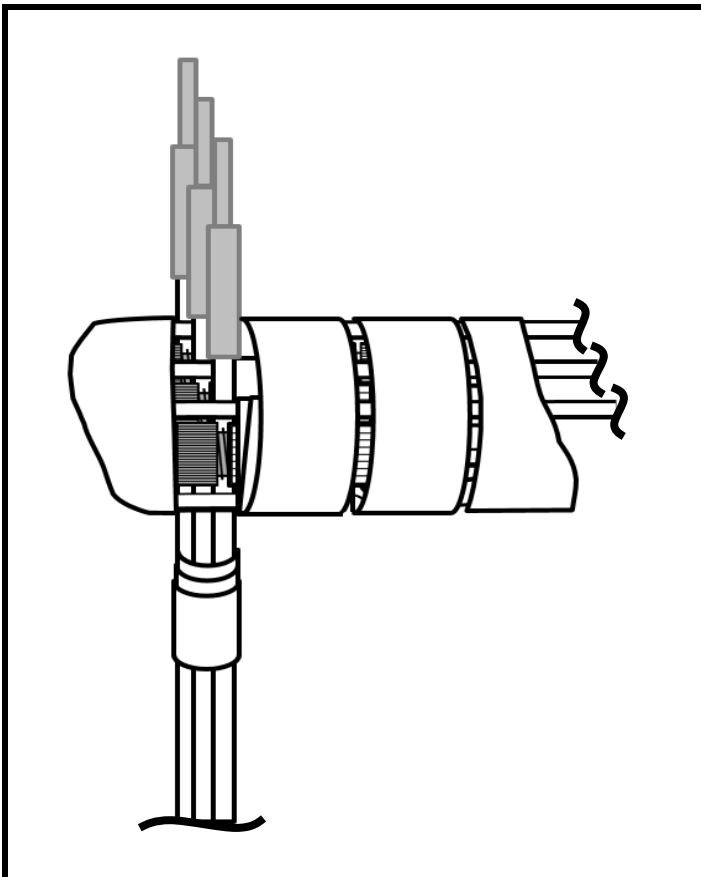

- A.13) Securing multiple Posi-Taps™ together  
a ) Once Posi-Taps™ are secured together with electrical tape they should look as shown.

## APPENDIX A - POSI-TAP PROCEDURE

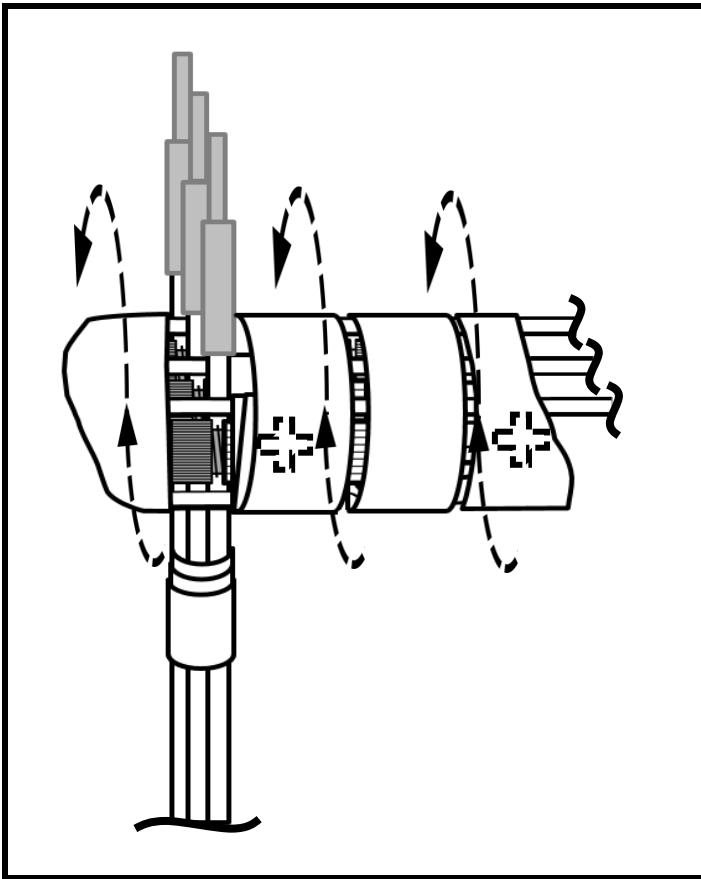

A.14) Securing multiple Posi-Taps™ together

- a ) To prevent any possible noise or rattle issues, use two pieces of Foam Tape, Gray (X) to wrap pre-taped Posi-Taps™.

**Foam Tape (X)**

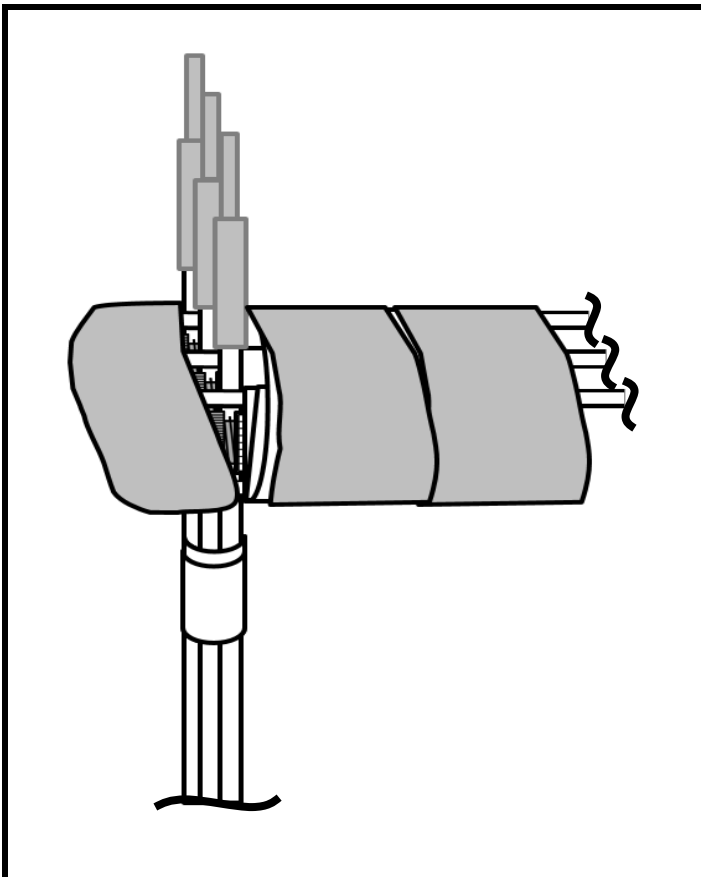

A.15) Securing multiple Posi-Taps™ together

- a ) Once wrapped with Foam Tape, taped Posi-Tap™ bundle should look as shown.

**APPENDIX B - MECHANIZATION DRAWING**

B.1) Figure below applies to the Welcome Lighting connected to the RH ASC

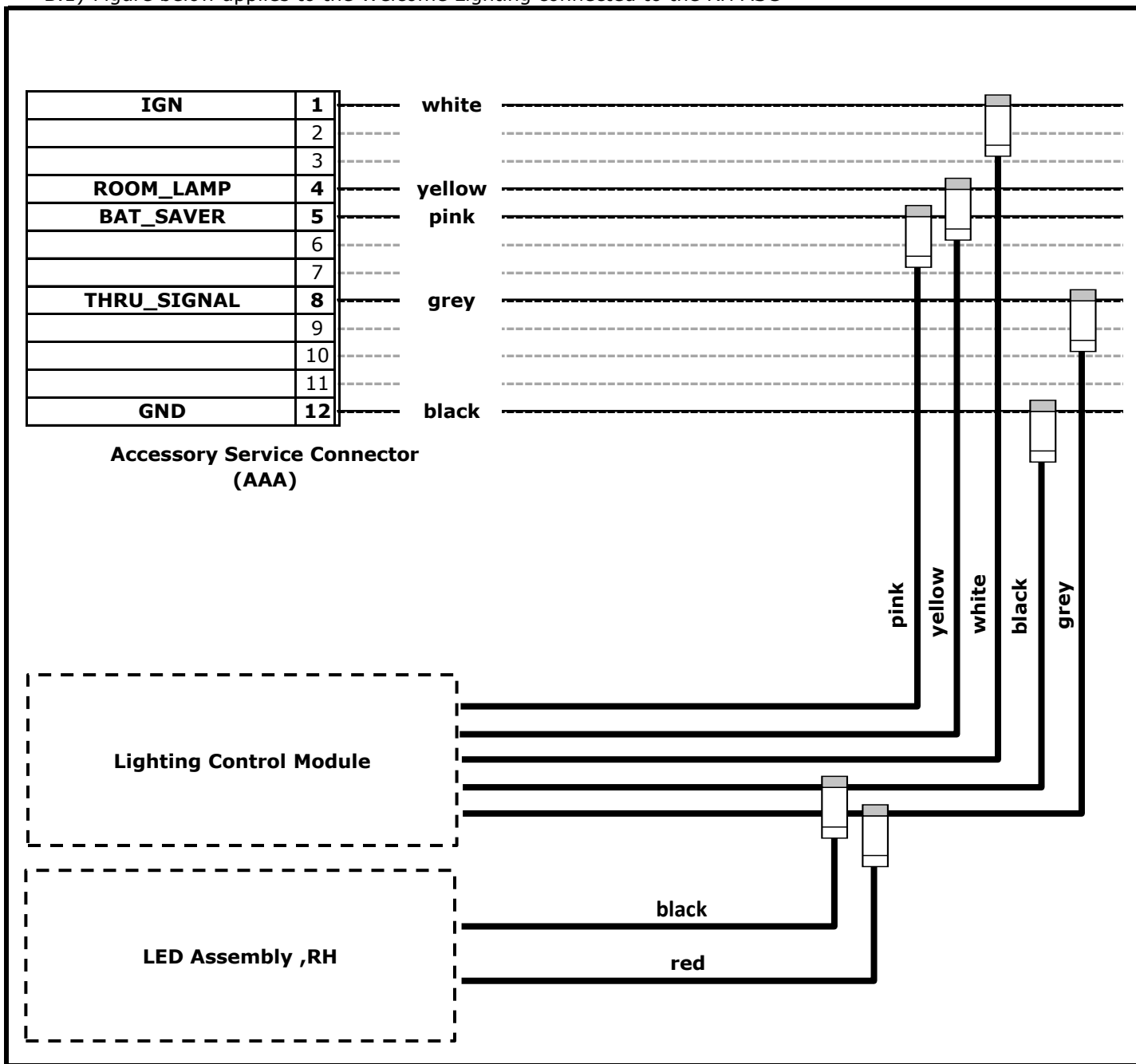

CONNECTOR PN#	T99F6 4RA0A
CONNECTOR NAME	ACCESSORY SERVICE CONNECTOR
CONNECTOR COLOR	WHITE

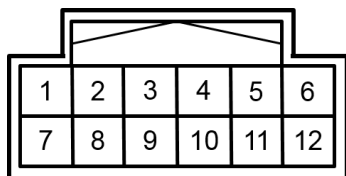
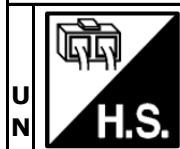

**LEGEND**

Posi-Tap™



- GRAY - CIRCUIT TAP (PIERCE) SIDE
- RED - ACCESSORY (INSERT) SIDE

Note: Pin location is referenced looking into harness side of connector with lock tab oriented as shown.

**APPENDIX B - MECHANIZATION DRAWING**

B.2) Figure below applies to the Welcome Lighting connected to the LH ASC

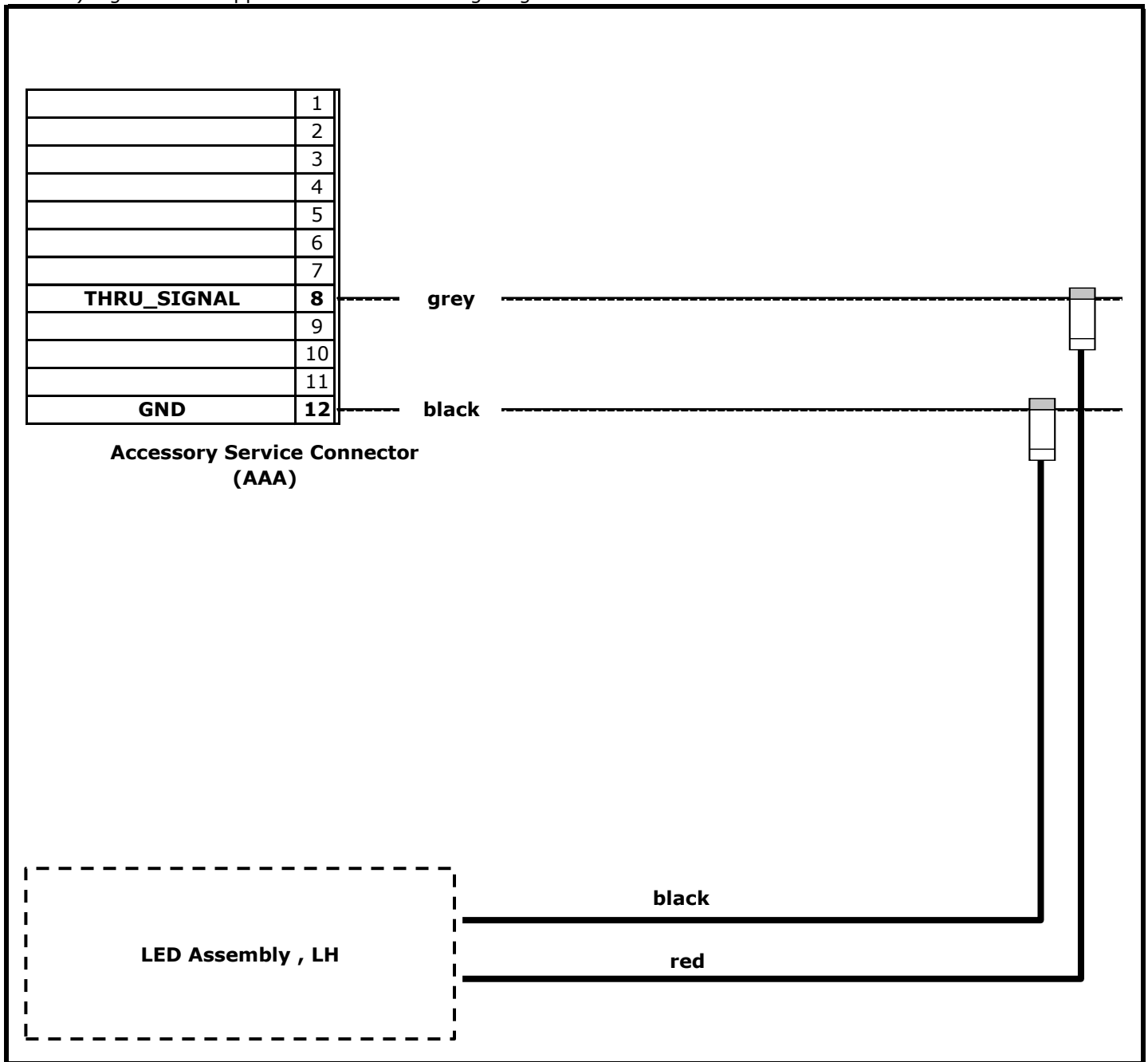

<b>CONNECTOR PN#</b>	T99F6 4RA0A	<b>LEGEND</b>
<b>CONNECTOR NAME</b>	ACCESSORY SERVICE CONNECTOR	 <b>GRAY - CIRCUIT TAP (PIERCE) SIDE</b> <b>RED - ACCESSORY (INSERT) SIDE</b>
<b>CONNECTOR COLOR</b>	WHITE	
<b>UNIT</b>	 	<p>Note: Pin location is referenced looking into harness side of connector with lock tab oriented as shown.</p>