



GENUINE PARTS

INSTALLATION INSTRUCTIONS

DESCRIPTION:	Illuminated Kick Plate
APPLICATION:	Versa Note
PART NUMBER:	999G6 4Z000

KIT CONTENTS:

Item	Qty.	Part Description	Service Part Number
A	1	Illuminated Kick Plate RH	999G6 4Z010
B	1	Illuminated Kick Plate LH	999G6 4Z020
C	2	Wire Harness	999G6 4Z030
D	6	Tie Wrap	N/A
E	2	Long Tie Wrap	N/A
F	4	Gray Urethane Foam Tape	N/A
G	4	Black Urethane Foam Tape	N/A
H	4	Posi Tap	EX-130RR
I	1	Installation Instructions Replacement Template	999V2 AW000
J	(2)	Accessory Service Connector (NOT INCLUDED IN KIT)	999Q9 AY001/T99F6 4RA0A

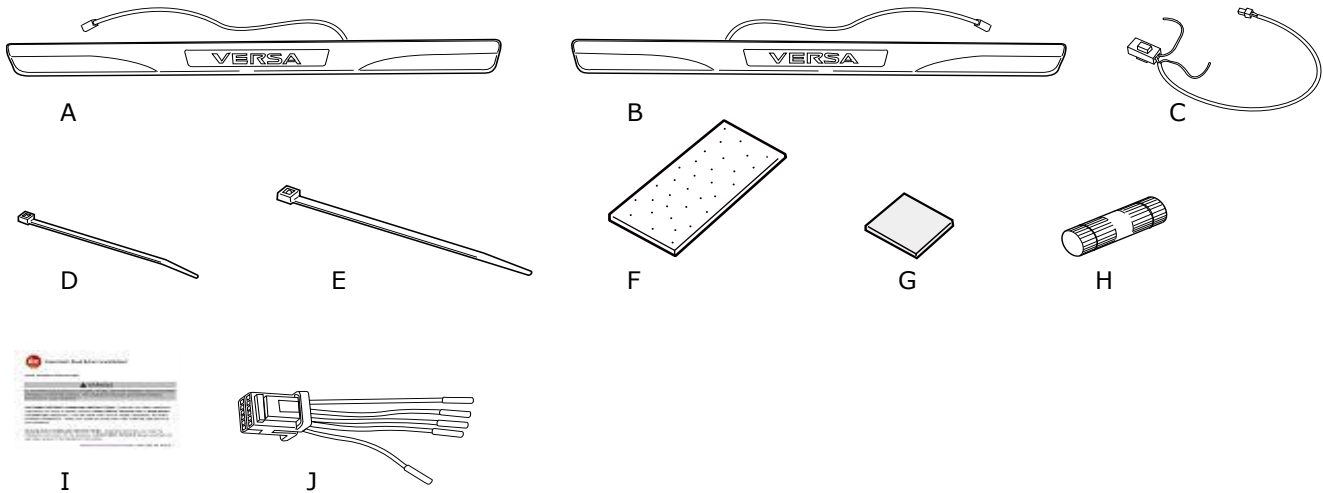

TOOLS REQUIRED:

- Nylon Removal Tool
- Masking Tape
- Ruler
- File
- Wire Cutter
- Flash Light
- Soft non Linting Towel
- Soap and Water
- 10mm Socket
- Scissors
- 50/50 alcohol & water solution

INSTALLATION PROCEDURE: PRE-INSTALLATION CAUTIONS / NOTES

⚠ CAUTION

- Dealer Installation Recommended. Instructions refer to Service Manual.
 - Please read this instruction carefully before installing this product for correct installation.
 - Please DO NOT use or install the part in ways other than what is described in this instruction manual.
 - If problem occurs during installation, please contact Nissan dealer where you purchased the product.
- 1) Apply parking brake
 - 2) Confirm the vehicle is no longer in the default shipping state (Extended Storage Switch Pulled Up and BCM in Transit Mode). Failure to confirm the vehicle has been removed from this state will result in the loss of normal vehicle operation. The confirmation requires two checks:

2a) Locate the Extended Storage Switch in the cabin fuse block. Once located, check that it is in the "Customer" position. See below for reference

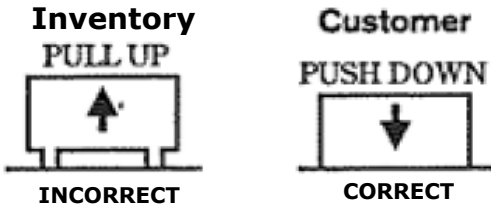

2b) To remove transit mode is by doing as follows:

1. Remove fuse cover lid
2. Push down shorting pin
3. Ign On 2 times without turn the vehicle on

To put transit mode back is by doing as follows:

1. Ign Off
2. Remove fuse cover lid
3. Pull up shorting pin
4. Assemble fuse cover lid
5. Ign On 2 times without turn the vehicle on

NOTE:

Typical vehicle condition shown above. Switch is easily identifiable by the permanent, push-pull fuse holder. Actual position on the fuse block may vary, vehicle to vehicle.

⚠ CAUTION

- Make sure the ignition is "OFF" before changing the switch position.

Condition	Switch Position	Note
Vehicle is delivered to the dealer	Inventory Condition	
Technician performs PDI	Customer Delivery	Turn switch back to Inventory position after PDI.
Customer test drives the vehicle	Customer Delivery	Turn switch back to Inventory position after test drive.
Vehicle is being stored at the dealer	Inventory Condition	
Vehicle is sold and delivered to customer	Customer Delivery	

NOTE: The Extended Storage Switch is only an aid to improve battery life during vehicle storage at the dealer. If the Extended Storage Switch fuse ever needs service after vehicle delivery, discard the Extended Storage Switch and install the correct fuse in its place.

- 3) Turn ignition switch to "ON" position
- 4) Record the customer radio presets and other presets as required

Preset	1	2	3	4	5	6		

- 5) Put shift lever in "P" position for A/T and CVT or "1st" for M/T
- 6) Turn ignition switch to "OFF" position

INSTALLATION PROCEDURE: PRE-INSTALLATION CAUTIONS / NOTES

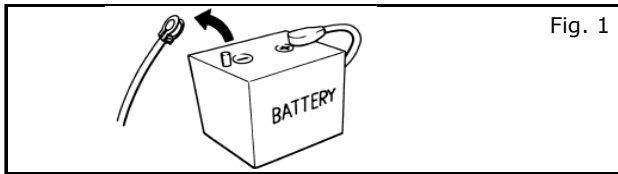

- 7) Disconnect the negative battery terminal.
- 8) Use seat and floor protection.
- 9) This part is to be installed at surface temperature of 65-100 deg.F.

INSTALLATION OVERVIEW:

CAUTION

- Take care not to scratch or damage any component during the removal or re-installation process.
- Trim pieces found to have witness marks or broken clips are not to be reinstalled.

- 1) Remove the following vehicle parts in the sequence shown below. Store these re-usable parts in a safe and protected manner.

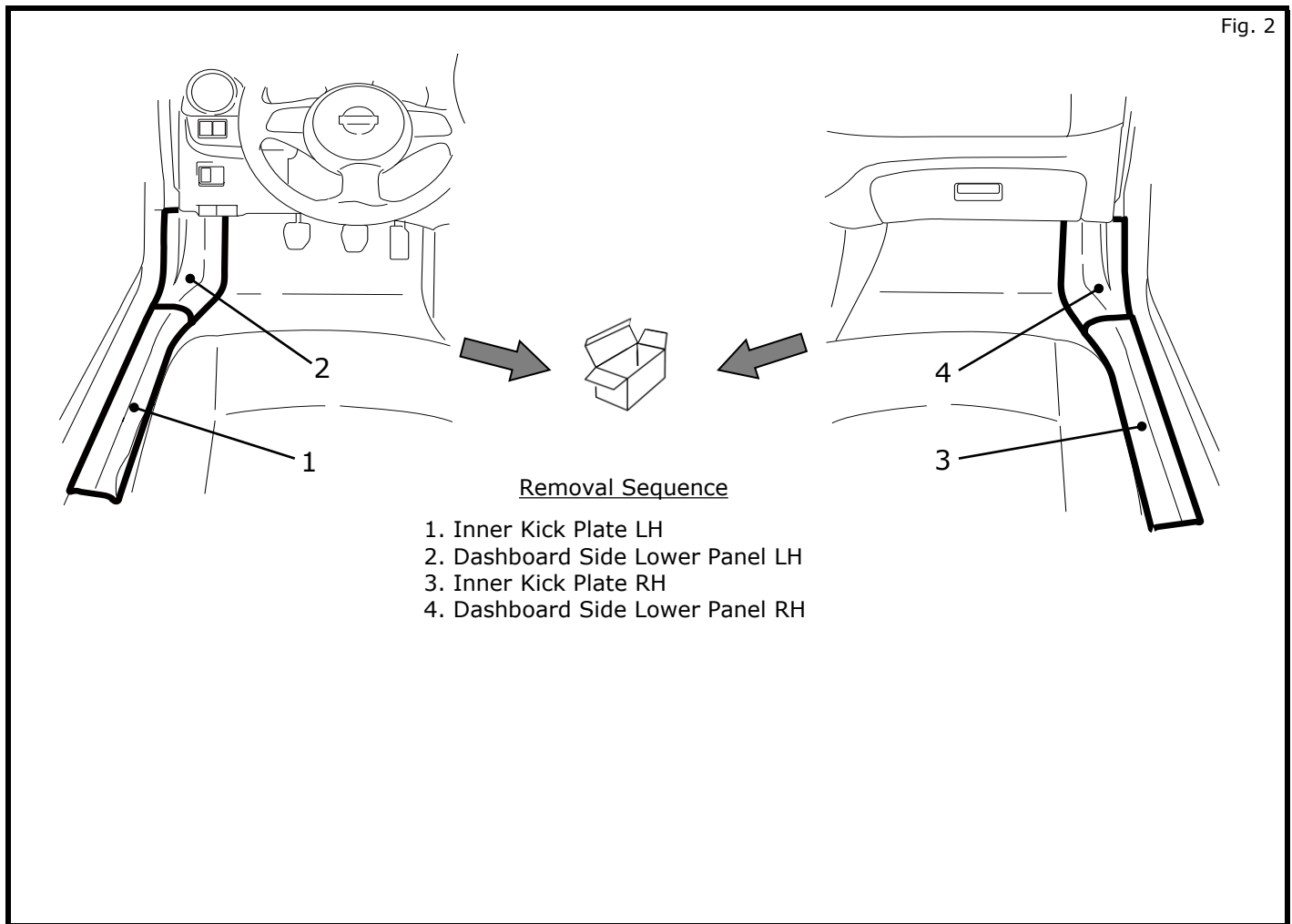

INSTALLATION OVERVIEW:

2) Installation Outline

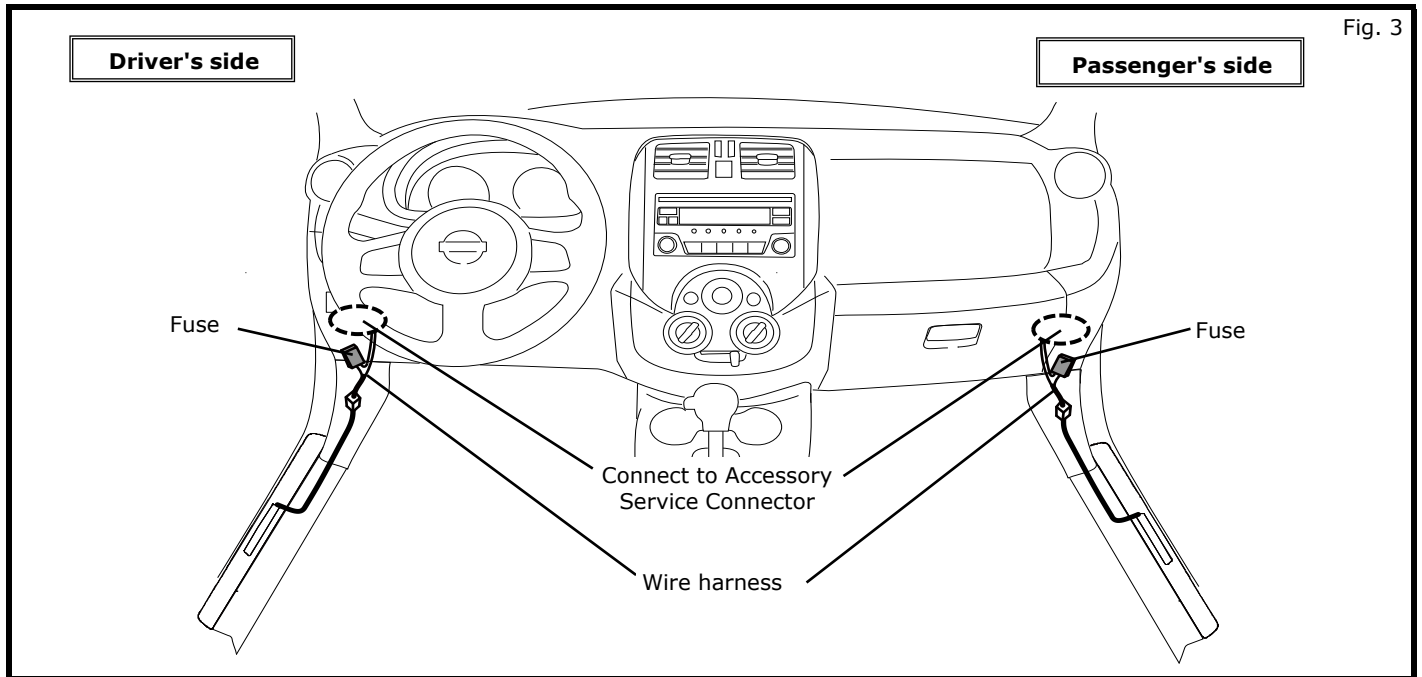

⚠ CAUTION

- Vehicle wiring color description is just for reference. Please refer to vehicle wiring diagram for details.

3) Mechanization

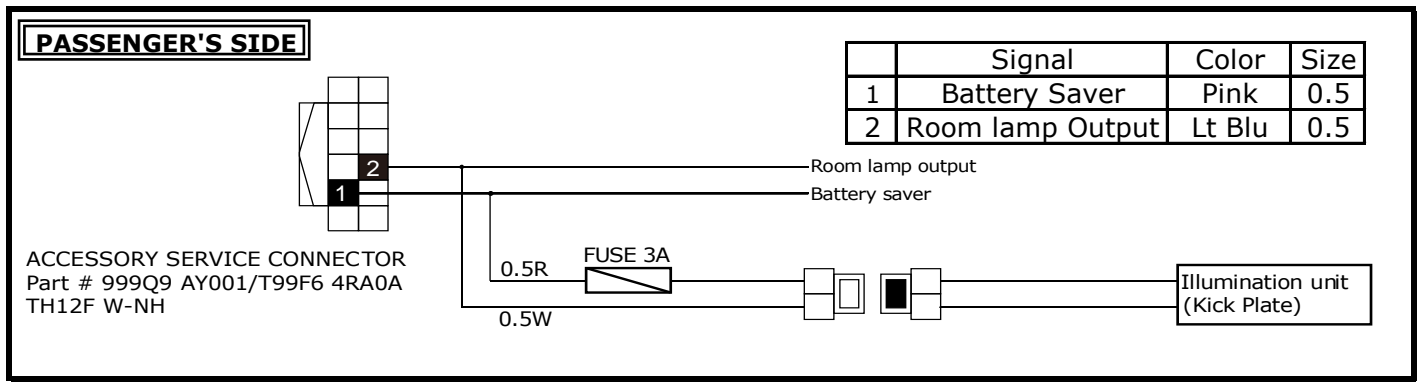
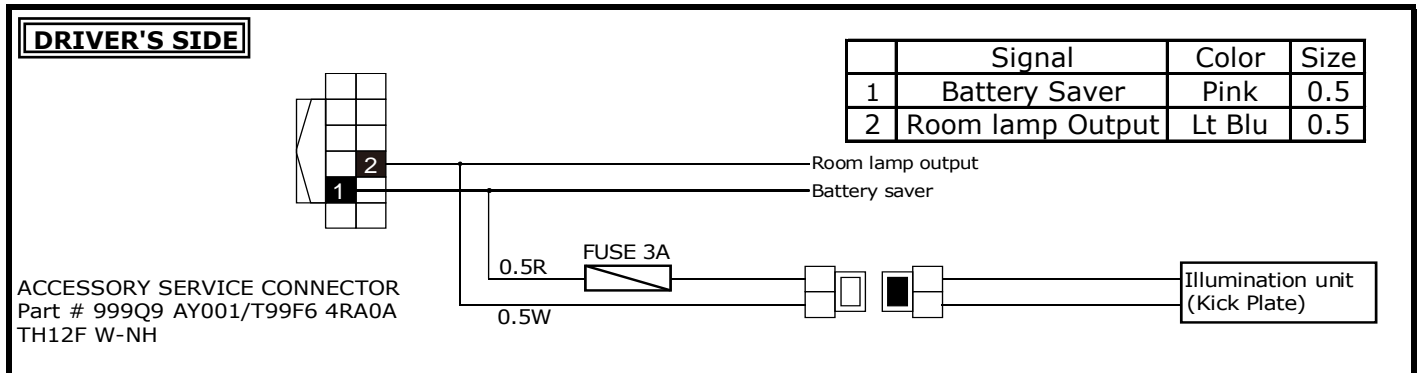

INSTALLATION PROCEDURE: VEHICLE PARTS REMOVAL

NOTE: The procedure below show the installation for LH side. Repeat procedure for RH side.

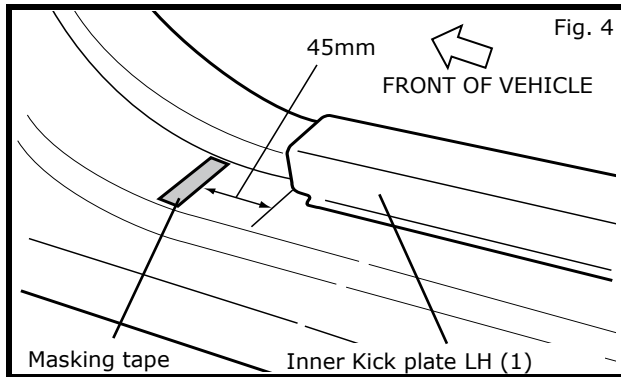

- 1) Measure 45mm from front of Inner Kick plate LH (1) and mark with masking tape as shown in Fig.4.

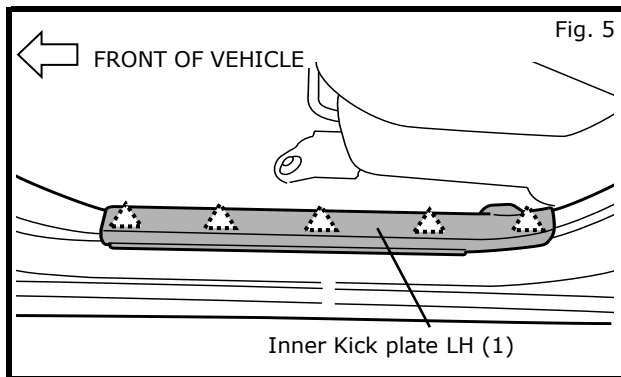

- 2) Inner Kick plate LH (1) removal
 - a) Remove Inner Kick plate LH (1) by pulling straight up to disconnect clips as shown in Fig.5.

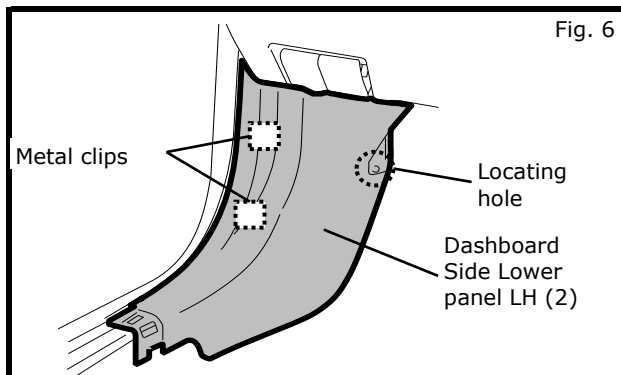

- 3) Dashboard Side Lower panel LH (2) removal
 - a) Remove Dashboard Side Lower panel LH (2) by pulling straight up to disconnect at metal clips and locating hole shown in Fig.6.

- 4) Repeat steps 1) through 3) for RH side of vehicle.
Inner Kick plate RH (3)
Dashboard Side Lower panel RH (4).

INSTALLATION PROCEDURE: WIRING HARNESS INSTALLATION

NOTE: The procedure below show the installation for LH side. Repeat procedure for RH side.

⚠ CAUTION

- Connector pull test should be less than 10kgf (22 lbs.) to confirm secure connection to vehicle Accessory Service Connector

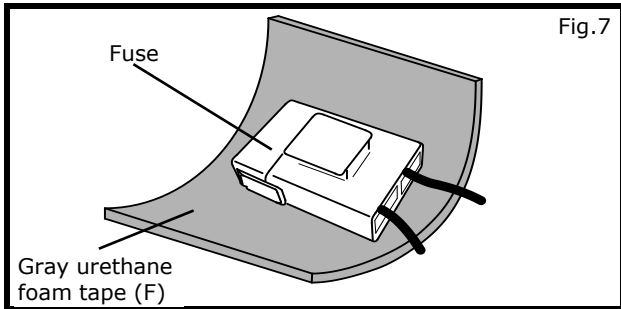

1) Wrap harness fuse (C) with Gray urethane foam tape (F) as shown in Fig.7.

2) Locate the Driver side "Accessory Service Connector (Part No. 999Q9-AY001/T99F6 4RA0A)" as shown in Fig.8.

Note: A previously installed accessory may be present. If so, carefully remove the Accessory Service Connector from the vehicle harness before Posi-tapping. It is recommended that all Posi-tapping be completed before reattaching the Accessory Service Connector to the vehicle harness.

Note: Be sure to grab the connector and not the harness when separating the plug from the foam tape.

3) Connect Wire harness (C) to "Accessory Service Connector (Part No. 999Q9-AY001/T99F6 4RA0A)" with Posi-Tap (H) as shown in below Illustration.

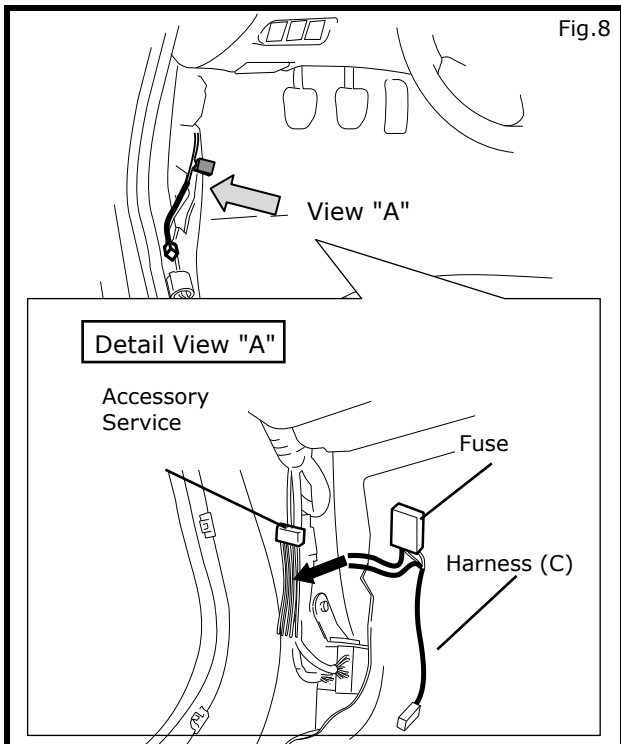

Tap position			
TH12FW-NH			
	1		
	2		
Accessory Service Connector		Wire Harness (C)	
	Signal	Color	Color
1	Battery Saver	PINK	RED
2	Room Lamp Output	Lt Blu	WHITE

Note: See next page on how to use Posi tap.

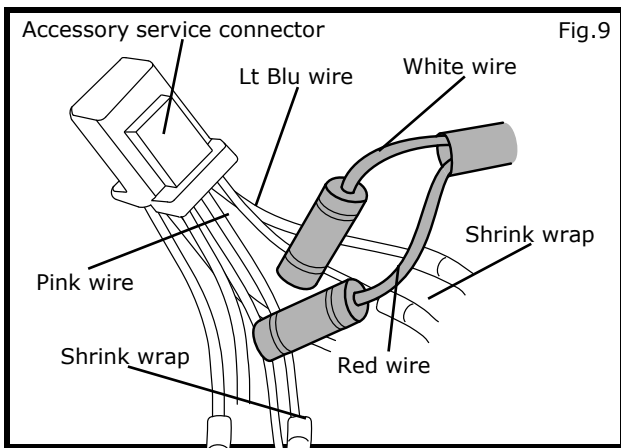

4) Using a Posi-Tap (H), connect the White wire from Wire harness (C) to the Lt Blu wire on the Accessory Service Connector as shown in Fig.9.

5) Using a Posi-Tap (H), connect the Red wire from Wire harness (C) to the Pink wire on the Accessory Service Connector as shown in Fig.9.

Note: Be sure NOT to Posi-Tap through the shrink wrap tubing.

INSTALLATION PROCEDURE:

WIRE HARNESS INSTALLTION

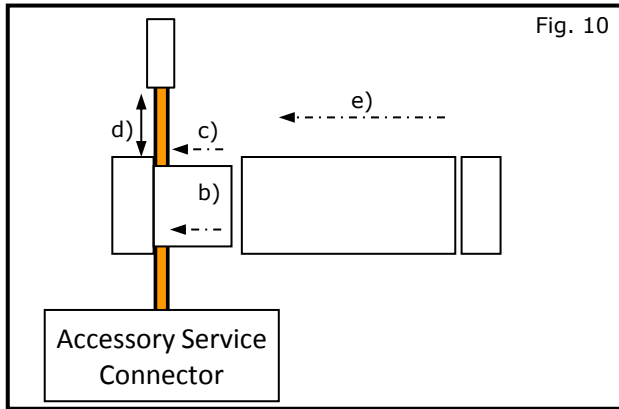

- 6) Tap vehicle wire.
 - a) Identify and confirm correct wire in the Accessory Service Connector to be tapped.
 - b) Remove cap (slot side) from tap body.
 - c) Slide cap around single accessory wire.
 - d) Position cap $\geq 0.25"$ (6.35mm) away from the heat shrink end of Accessory Service Connector.
 - e) Tighten the tap **TIGHT** with finger pressure.
 - f) Tighten by another quarter turn.

NOTE:

Figures are not to scale. Do not re-use the tap.

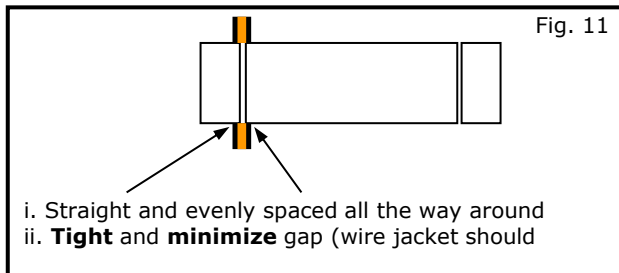

- 7) Inspect the tap to ensure correct installation.

NOTE:

Avoid putting pressure on the vehicle wire and tap for the remainder of the installation.

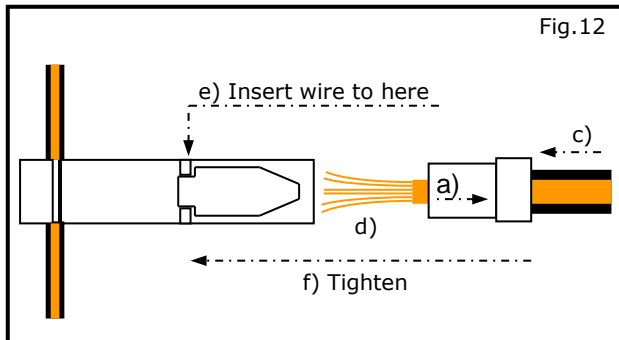

- 8) Tap accessory wire.
 - a) Remove tap (non-pierce) side from tap.
 - b) Remove the protective stub from the wire.
 - c) Insert wire through the non-pierce side opening.
 - d) Spread the individual strands into fan shape.
 - e) Insert wire into the tap body and ensure that it is all the way in.
 - f) Tighten the tap **TIGHT** with finger pressure.
 - g) Tighten by another quarter turn.

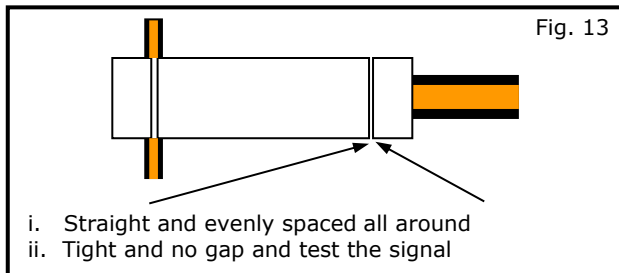

- 9) Confirm the tapped accessory wire.
 - a) Pull on the wire lightly to ensure connection.
 - b) Inspect the tap to ensure correct installation.
 - c) Test the signal to ensure that it is working properly.

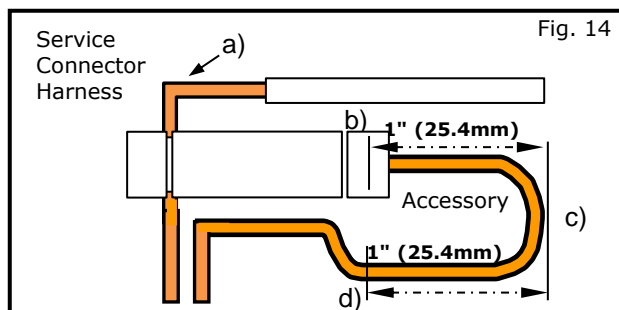

- 10) Forming strain relief loop (always required).
 - a) Gently bend the end of the pierced wire (where it exits the cap) down towards body of posi-tap.
 - b) Starting at b), measure 1" (25.4mm), then make the first bend of the loop c) up toward the body of the posi-tap, from b) measure 1" (25.4mm), then make the second bend of the loop d) in towards the posi-tap so it can be secured with electrical tape.

INSTALLATION PROCEDURE: WIRE HARNESS INSTALLTION

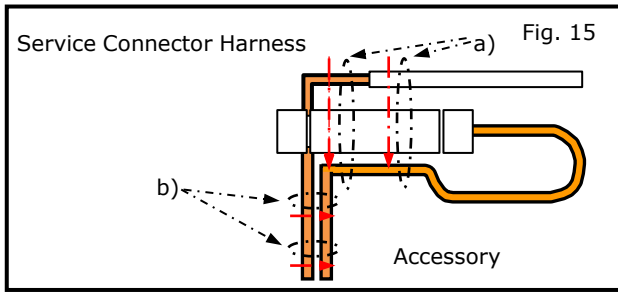

- 11) Securing the tapped accessory.
 - a) Secure the pierced wire and the tapped wire on the non-pierce side to the body of the tap with electrical tape (≥ 2 revolutions).
 - b) Secure the pierced wire and the tapped wire on the non-pierce side to each other with electrical tape (≥ 2 revolutions).

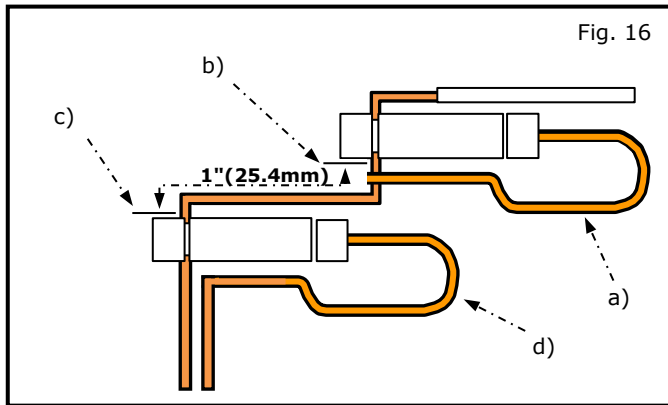

- 12) Putting a second tap on the same wire.
 - a) Tap first accessory, then form a strain relief loop as shown in Fig 1 thru 5a. Do not secure wire until additional tap has been installed
 - b) Measure 1" (25.4mm) from point b) to point c) and install the second accessory tap. Bend the wire gently to form the "staircase" shape.
 - c) After tapping the second accessory, form a strain relief loop d) as shown in Fig 5a

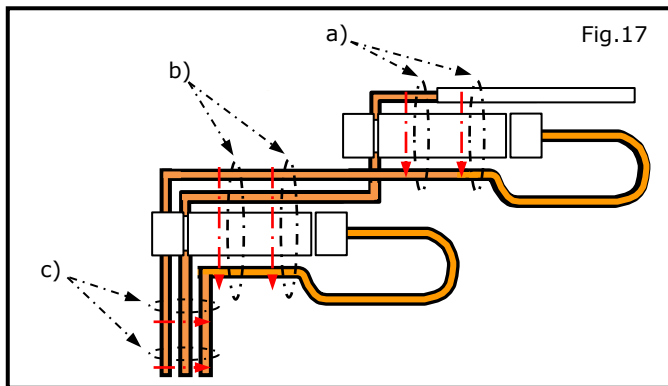

- 13) Securing multiple accessory taps.
 - a) Secure the pierced wire and the tapped wire on the non-pierce side to the body of the tap with electrical tape (≥ 2 revolutions).
 - b) Secure the pierced wire and the tapped wire on the non-pierce side from the first posi-tap to the body of the 2nd tap with electrical tape (≥ 2 revolutions).
 - c) Secure the pierced wire from the last tap and the tapped wires from the non-pierced sides of each tap to each other with electrical tape (≥ 2 revolutions).

NOTE:

The Accessory Service Connector is only for the installation of Genuine Nissan or Nissan approved accessories, Nissan shall not otherwise be liable for loss or damages due to the installation of non approved accessories.

INSTALLATION PROCEDURE: WIRING HARNESS INSTALLATION

NOTE: The procedure below show the installation for LH side. Repeat procedure for RH side.

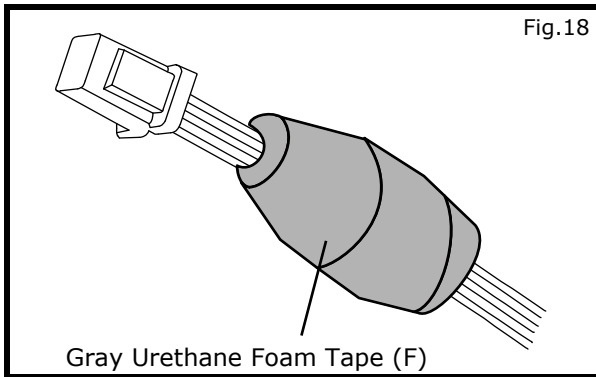

14) Cut one piece of Gray urethane foam tape (F) in half. Then, Wrap the Posi-Taps with Gray Urethane foam tape (F) to prevent rattle as shown in Fig.18. Use other half piece of Gray urethane foam tape for RH side.

15) Then plug the Accessory Service Connector into the vehicle harness on the driver side.

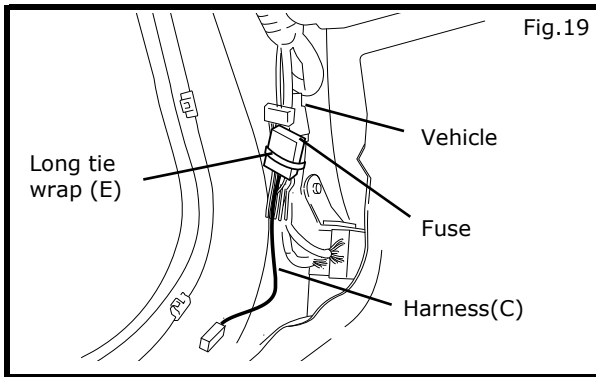

16) Attach fuse on Wire harness (C) to vehicle harness at the position as shown in Fig.19, by Long tie wrap (E). (1 place)

17) Repeat steps 1) through 16) for RH side of vehicle.

INSTALLATION PROCEDURE: WIRING HARNESS INSTALLATION

NOTE: The procedure below show the installation for LH side. Repeat procedure for RH side.

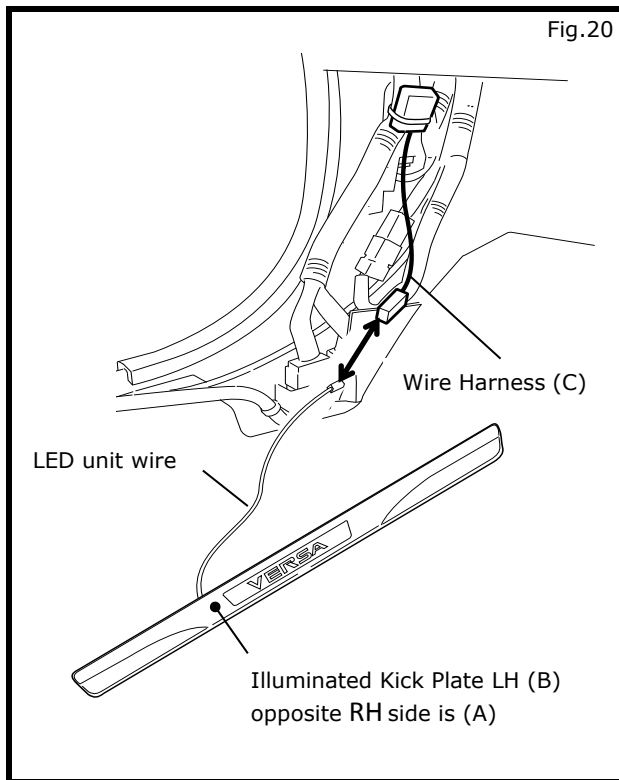

- 18) Function check
- Connect Wire harness (C) to Illuminated Kick Plate LH (B) LED unit wire as shown in Fig.20. (RH side is "A")
 - Connect battery.
 - Check function. Confirm RH/LH "VERSA" text is Illuminated when either door is in the open position. Manual engage door switch to verify Illuminated Kick Plate turns OFF when room lamp goes OFF as shown in Fig.21.
 - If OK, disconnect Wire harness (C) from the lamp unit harness of Illuminated Kick plate (B). (RH side is "A").
 - If NG, check harness routing, connections and LED unit to identify root cause. Repeat steps a) to c) until unit is properly working.
 - Disconnect battery as shown in Fig.22.

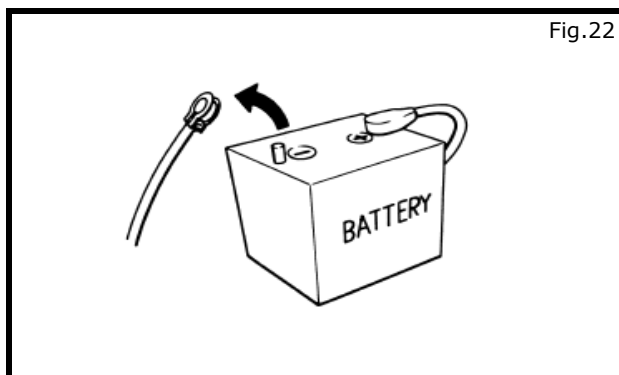
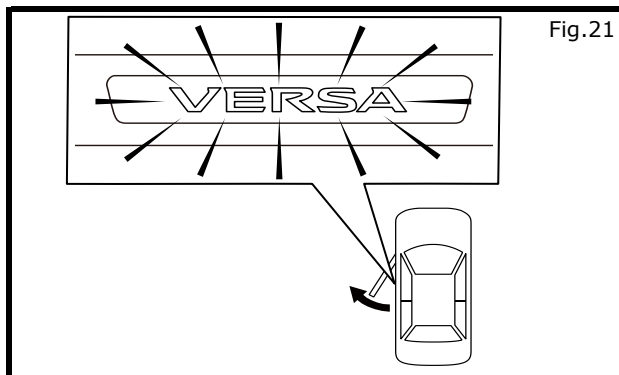

INSTALLATION PROCEDURE: ILLUMINATED KICK PLATE INSTALLATION

NOTE: The procedure below show the installation for LH side. Repeat procedure for RH side.

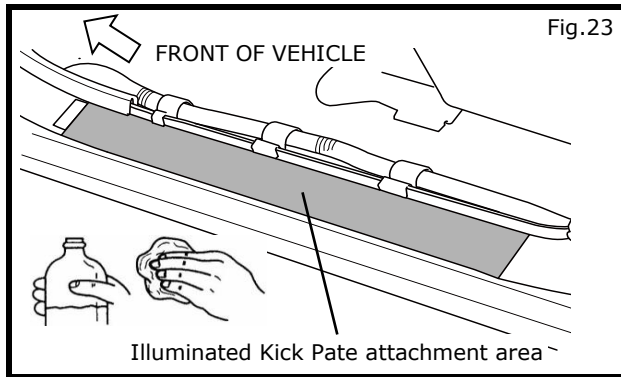

- 1) Clean the Illuminated Kick Plate attachment area as shown in Fig.23 with 50/50 alcohol & water, let dry for 30 seconds.

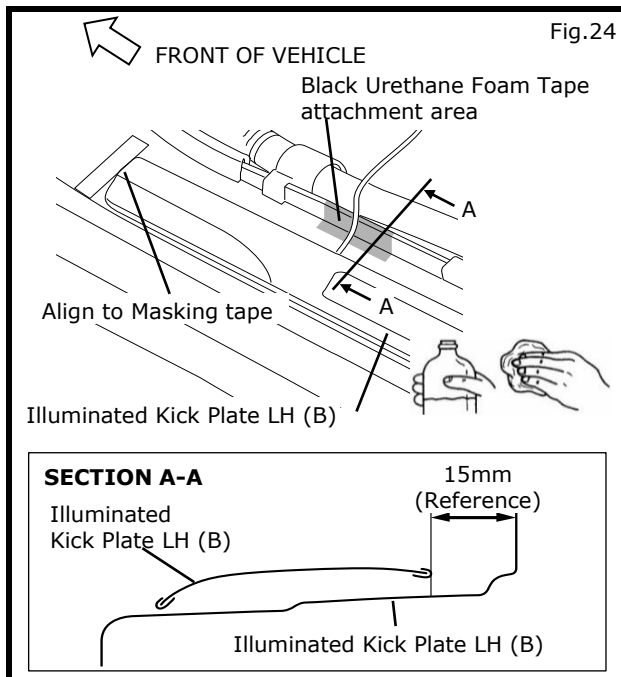

- 2) Set Illuminated Kick Plate LH (B) to body side panel as shown in Fig.24. Then confirm the position of the Black Urethane Foam Tape attachment area.
- Note: Do Not remove tape's liner of Illuminated Kick Plate LH (B) at this time.**

- 3) Remove Illuminated Kick Plate LH (B).
- 4) Clean the Black Urethane Foam Tape attachment area as shown in Fig.24 with 50/50 alcohol & water, let dry for 30 seconds.

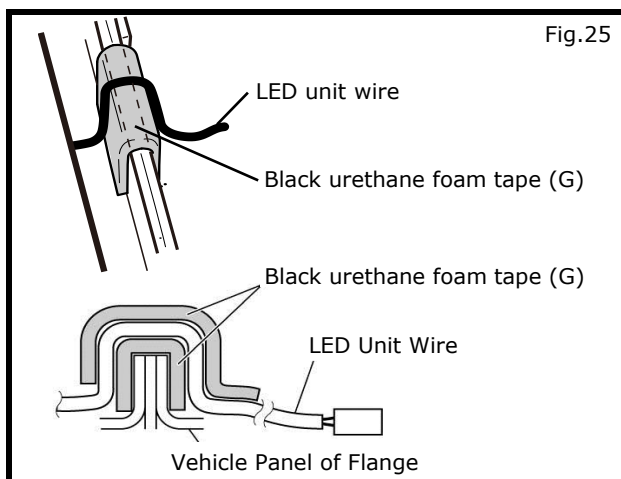

- 5) Attach the Black Urethane Foam Tape (G) to vehicle panel flange as shown in Fig.25.
 - 6) Set Illuminated Kick Plate LH (B) to body side panel as shown in Fig.24.
- Note: Do Not remove tape's liner of Illuminated Kick Plate LH (B) at this time.**
- 7) Place the LED unit harness on top of the Black Urethane Foam Tape (H), then apply another Black Urethane foam Tape (G) on top of the harness as shown in Fig.25.

INSTALLATION PROCEDURE: ILLUMINATED KICK PLATE INSTALLATION

NOTE: The procedure below show the installation for LH side. Repeat procedure for RH side.

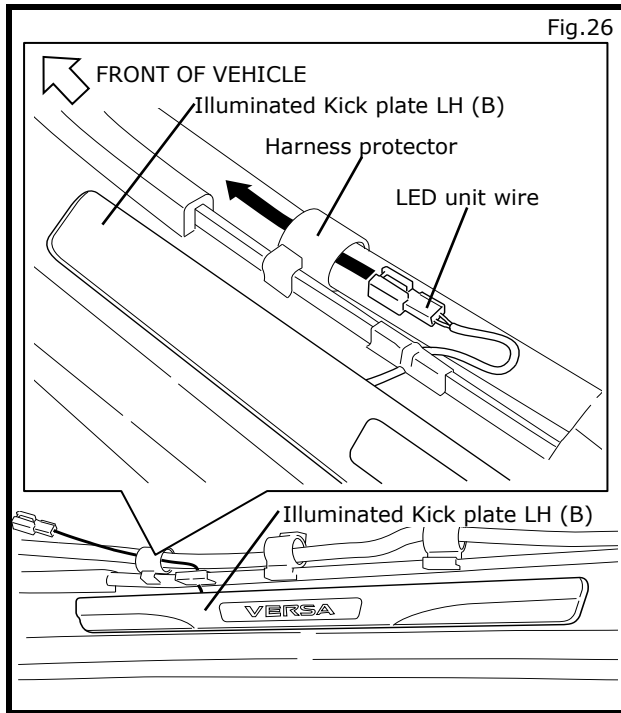

8) Route LED unit wire of Illuminated Kick plate LH (B) into harness protector as shown in Fig.26.

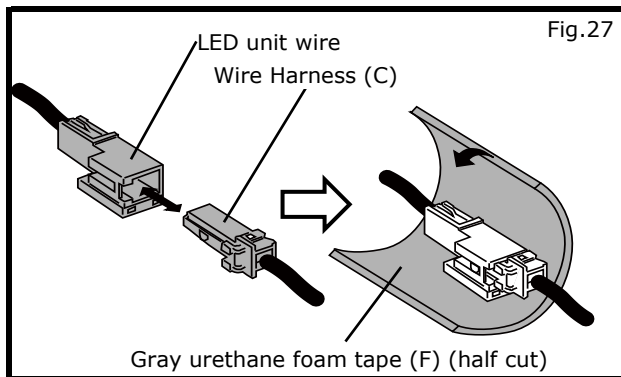

9) Connect LED unit wire (B) to Wire harness (C) then cut one piece of Gray Urethane Foam Tape (F) in half, apply one half around connecting section as shown in Fig.27. Use other half piece of Gray Urethane Foam Tape for RH side.

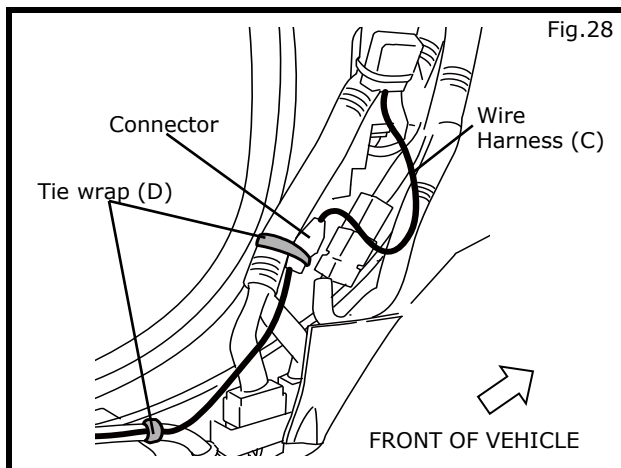

10) Secure Wire harness (C) to vehicle harness with Tie wrap (D) as shown in Fig.28. (2 place)

CAUTION

- Do not attach the harness to sharp metal edge.

INSTALLATION PROCEDURE: ILLUMINATED KICK PLATE INSTALLATION

NOTE: The procedure below show the installation for LH side. Repeat procedure for RH side.

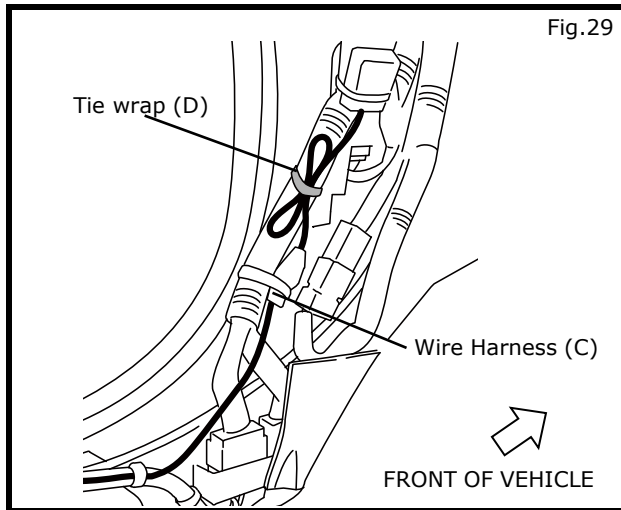

- 11) Attach excessive Wire harness (C) to the vehicle harness with Tie wrap (D) as shown in Fig.29.
(1 place)

CAUTION

- Do not attach the harness to sharp metal edge.

- 12) By using file, remove surface as shown in section B-B on edge of Inner Kick plate (1) at location of 120mm from front end as shown in Fig.30.

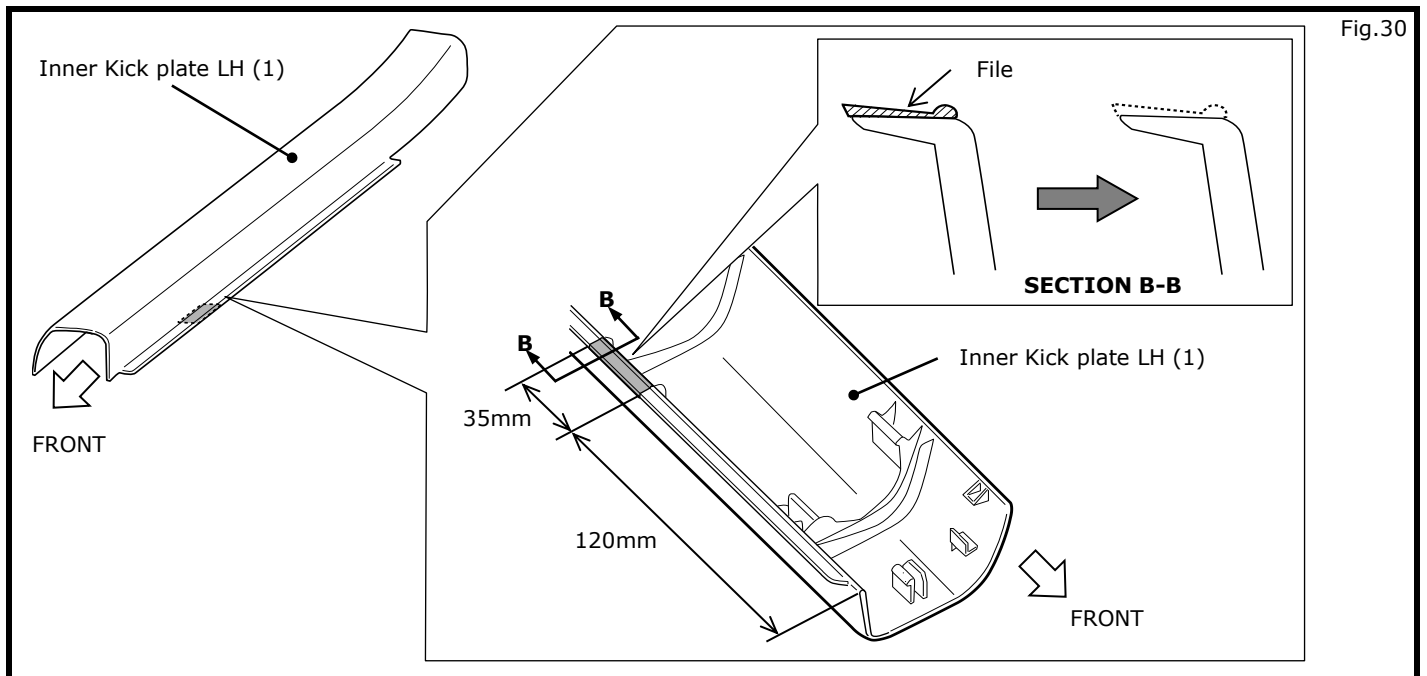

INSTALLATION PROCEDURE: ILLUMINATED KICK PLATE INSTALLATION

NOTE: The procedure below show the installation for LH side. Repeat procedure for RH side.

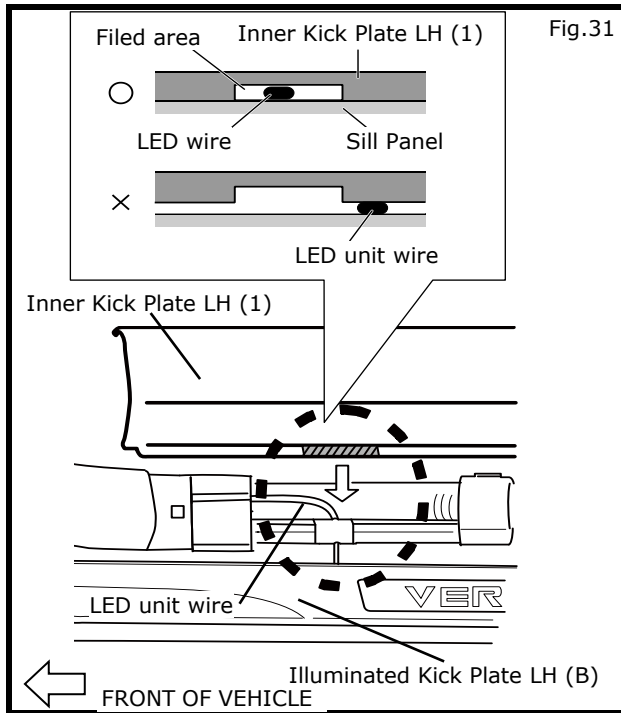

13) Reinstall Dashboard Side Lower panel LH (2)

14) Reinstall Inner Kick Plate LH (1).

At that time route the LED unit wire to filed area as shown in Fig.31.

15) Turn up Illuminated Kick Plate LH (B), then remove all tape's liners as shown in Fig.32.

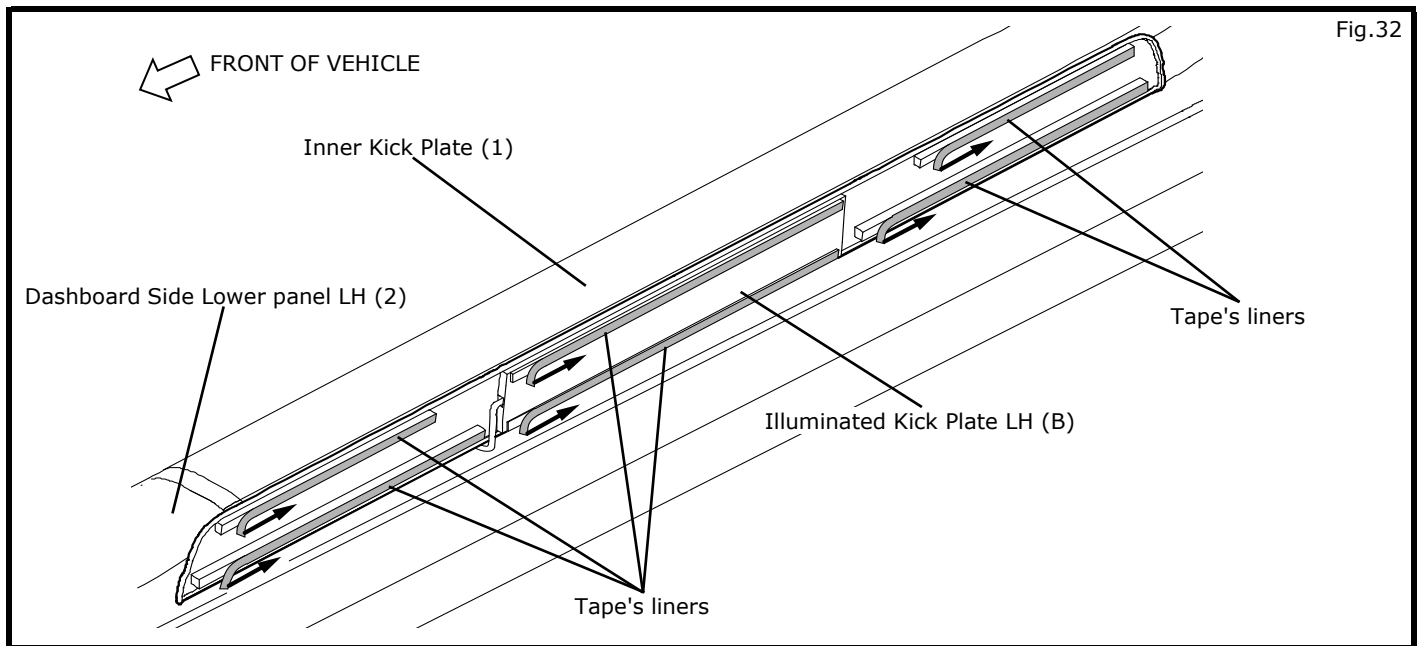

INSTALLATION PROCEDURE: ILLUMINATED KICK PLATE FRONT INSTALLATION

NOTE: The procedure below show the installation for LH side. Repeat procedure for RH side.

16) Align Illuminated Kick Plate LH (B) to masking tape and Inner Kick Plate (1) as shown in Fig.33.

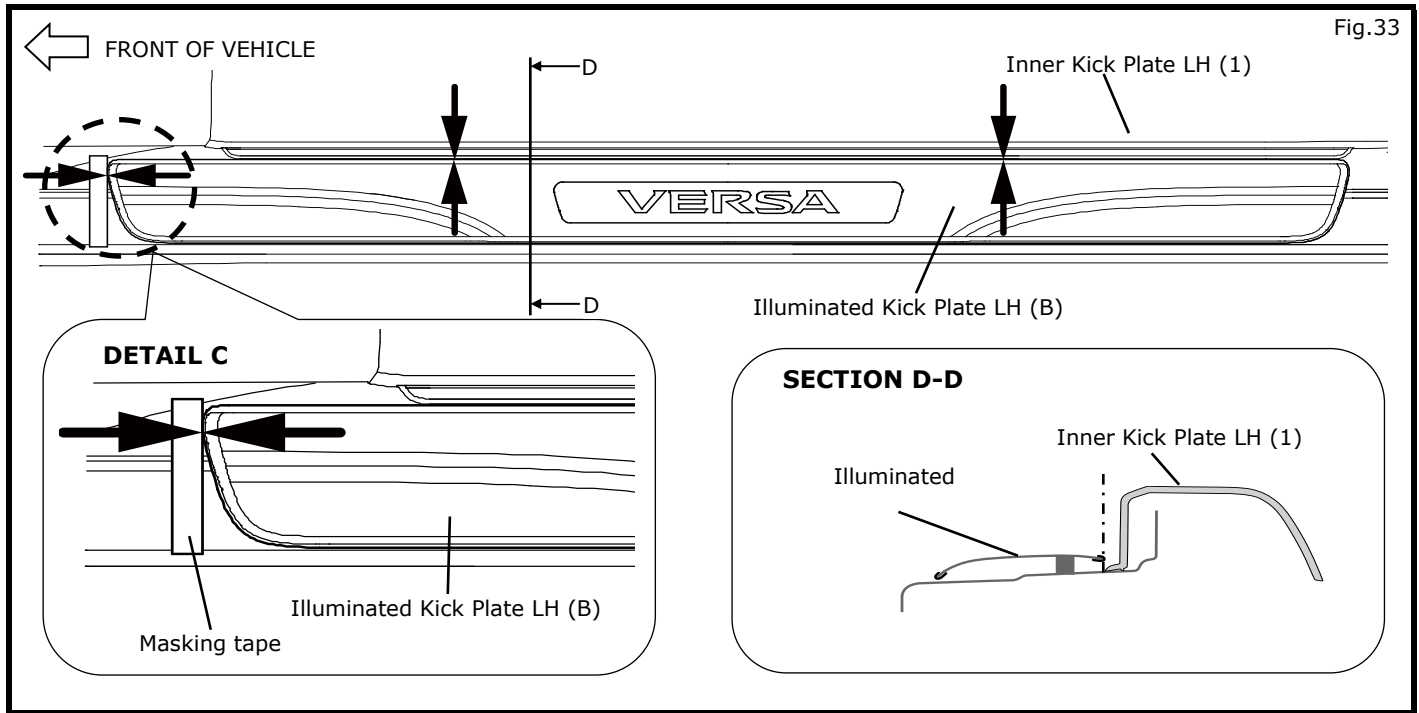

NOTE:

Make sure no visual gap between Illuminated Kick Plate (B) and Inner Kick Plate (1) plastic trim edge as shown in SECTION D-D Fig.33.

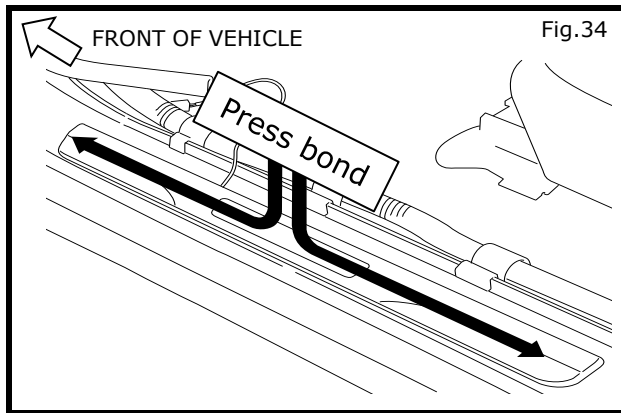

17) Apply minimum 11lb (49N) of pressure along the part to secure tape to body as shown in Fig.34.

CAUTION

- Use caution when applying pressure as the surface may dent.

ACCESSORY CHECK: (Must for any accessory that uses the vehicle battery for power)

- Connect the battery negative terminal and tighten the nut to 5.4 N-m (47.8 lb-in)
- Check all **Critical Installation Steps**.
- Check all **torque** values. (Reference related steps and figures)
- Verify all wiring is secure and not exposed.
- Trim all excess cable ties flush.
- Check function. Confirm RH/LH "VERSA" text is Illuminated when either door is in the open position. Manual engage door switch to verify Illuminated Kick plate turns OFF when room lamp goes OFF**
- Check all vehicle electrical systems that the accessory interfaces with.
 - Vehicle electrical system 1 (Must for pre-wiring, overlay harness, and Posi-Tap)
 - Vehicle electrical system 2 (Electrical system(s) that the accessory connects to)

RE-INSTALLATION OF REMOVED PARTS:

- Re-install all removed vehicle parts. Refer to the vehicle service manual as necessary.

 CAUTION

Use caution when re-installing interior components to avoid damage, scratches, or breaking of mounting clips. Refer to the vehicle service manual for more information.

- Clean interior of vehicle.

FINAL INSPECTION:

- Verify re-installed trim parts for proper flush fit (no gap, no waviness, etc.).
- Verify all clips are fully engaged and locked.
- Verify re-installed trim parts are free from cracks, scratches or stress marks.
- Verify vehicle headliner, seat, steering wheel, center console, floor carpets, etc. are not soiled.
- Verify interior and exterior is not damaged.
- Turn ignition switch to "ON" and confirm proper operation of Vehicle Systems
 - If equipped, verify all window and sunroof one touch operation and perform the reset procedure if necessary. Refer to the vehicle service manual for more details.
 - Confirm proper audio function (AM, FM, SAT, CD and AUX).
- Start engine and verify that there are no new Diagnostic Trouble Code. Turn ignition switch to "**OFF**".
- Place the Owner Manual, Quick Reference Guide, and/or other Manual in the glove box.
- If this vehicle will be returned to a dealer lot or showroom for an extended period of time, be sure the extended storage switch is placed in the "inventory" position. Refer to the Extended Storage Switch verbiage at the beginning of the 'INSTALLATION PROCEDURE' section.
- Re-program radio presets and other vehicle settings to the recorded settings. No need to do this step if the extended storage switch is placed in the "inventory" position.

CAUTION

- **Do NOT step on kick plate and wash vehicle for 24 hours after installing to prevent the double-sided tapes from peeling.**
- **When turn off the ignition switch, do NOT let the door opening for long time, or else electrical source can be used up.**

NOTE:

Posi-Tap™ is protected by patent # 5,228,875 5,695,369 5,868,589 6,692,313 Jap 2881414 Aus 708700 Tia 103534 Can 2204826 Mex 200626 Korea 477279 China Z197105562.9 & others pending.