



GENUINE PARTS

INSTALLATION INSTRUCTIONS

DESCRIPTION: Body Side Molding

APPLICATION: Altima

PART NUMBER: T99G2 6CA01

KIT CONTENTS:

Item	Qty.	Part Description	Service Part Number
A	1	Molding - LH Front Door	T99G2 6CA0B
B	1	Molding - LH Rear Door	T99G2 6CA0E
C	1	Molding - RH Front Door	T99G2 6CA0C
D	1	Molding - RH Rear Door	T99G2 6CA0D
E	1	LH Installation Template	T99G2 6CTEM01
F	1	RH Installation Template	T99G2 6CTEM01
G	1	Installation Instruction - Half Sheet	999V2 AW000

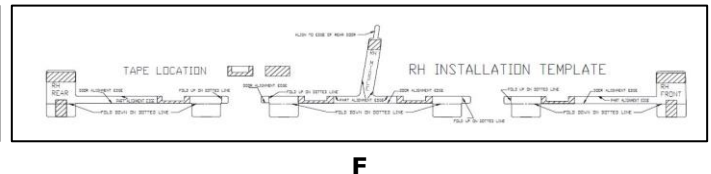
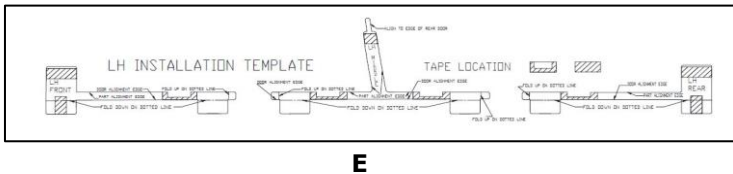
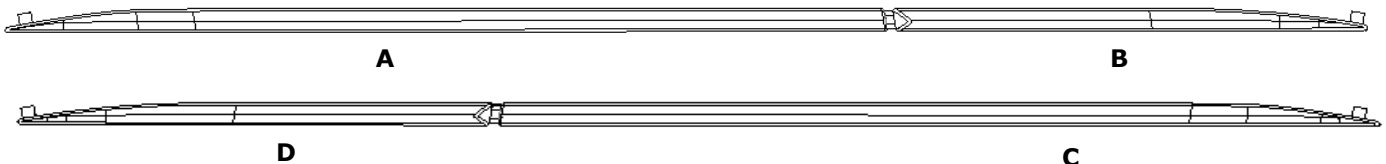

TOOLS REQUIRED:

- Clean, lint-free wiping cloth
- 90% or greater alcohol solution
- Scissors
- Masking Tape
- Roller (optional)

PRE-INSTALLATION WARNINGS, CAUTIONS, CRITICAL STEPS, and NOTES:

- Dealer installation recommended. Instructions may refer to service manual.
- Identify the kit contents before starting the installation process.
- Break the LH & RH installation template from the card stock E&F along the perforated dotted line.
- Recommended to do this body side molding installation, when the vehicle is on hoist.

CAUTION

- Failure to clean mounting surface properly may cause tape to have poor adhesion to vehicle.
- If vehicle has been recently repainted, please allow vehicle paint to dry and age 24 hours before installing body side moldings.
- Install body side moldings when ambient temperature is above 15°C (60°F).
- Do not wash or expose vehicle to a wet environment for 24 hrs after installing moldings.
- Please use proper pressure of 103kPa (15Psi) to adhere body side molding to door.
- These installation instructions are for left side of vehicle; same procedure applies to right side.
- Alignment of all body side moldings must be on flat door surfaces. Moldings can not hang over door edges and no gaps allowed. Please follow instructions very carefully for alignment of molding to door edges.

INSTALLATION PROCEDURE:

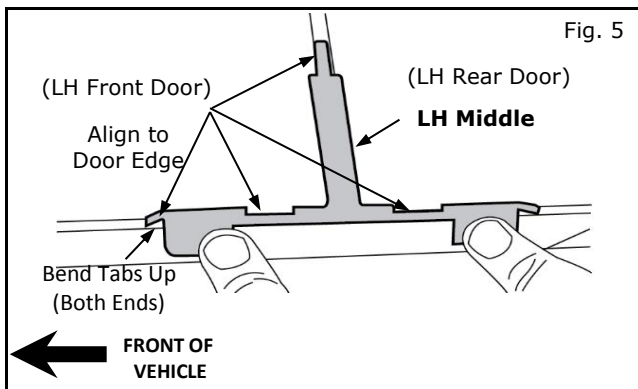
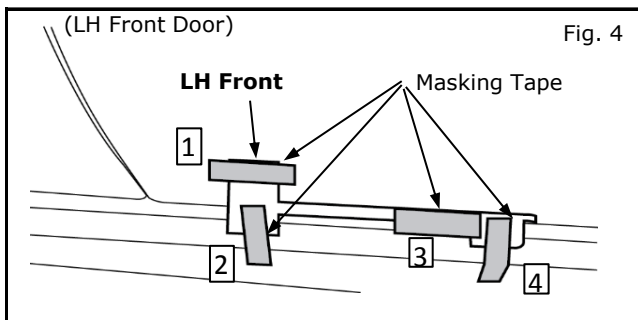
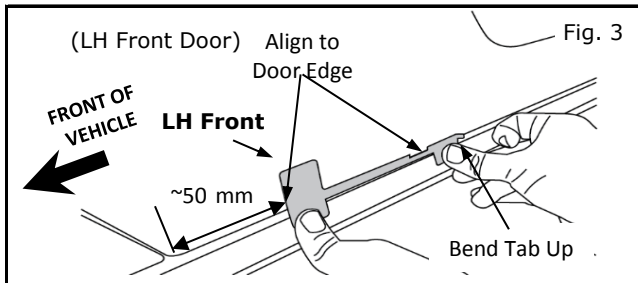
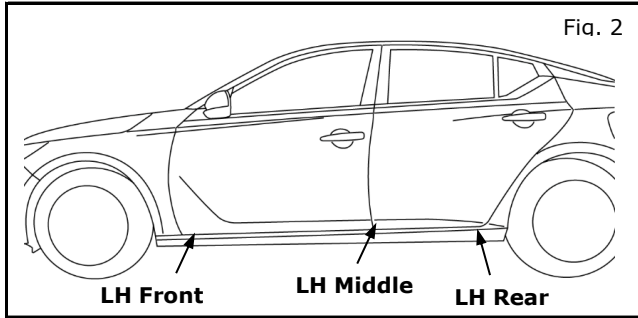
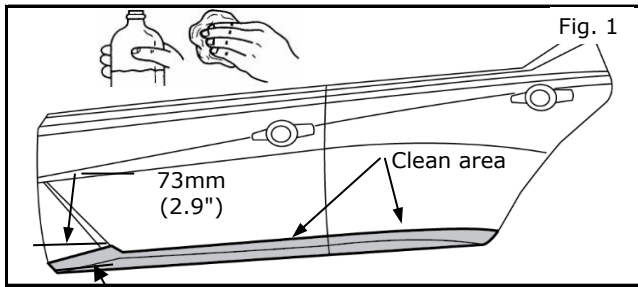

- 1) Clean driver's side vehicle area thoroughly with soap and water to remove any dirt or debris and allow to dry.
- 2) Using a clean, lint-free cloth and 90% alcohol solution, clean area on doors where part will be installed.

NOTE: Once cleaned, do not contaminate this surface by touching it with bare hands.

- 3) Overview of template locations on the vehicle door.
- 3) LH Front Template- Fold aft tab up and place template as indicated.
- 4) Align template edges as shown in Fig. 3 with front door edges.
- 5) Secure front template with 1/2" masking tape in the locations & sequence shown.
- 6) Remove LH Middle template and fold fwd/aft tabs up and place template as shown on Front/Rear door.
- 7) Align template edges as shown in Fig. 5 with the Front/Rear door edges.

INSTALLATION PROCEDURE:

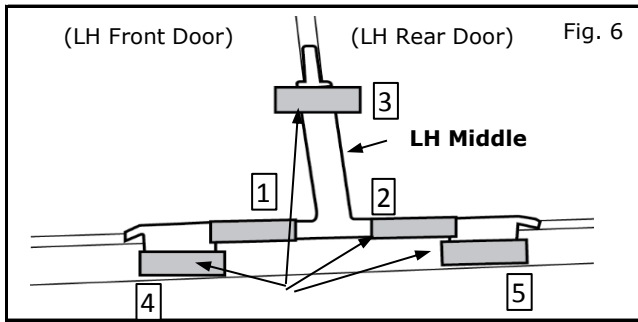

- 8) Secure middle template with 1/2" masking tape in the locations & sequence shown.

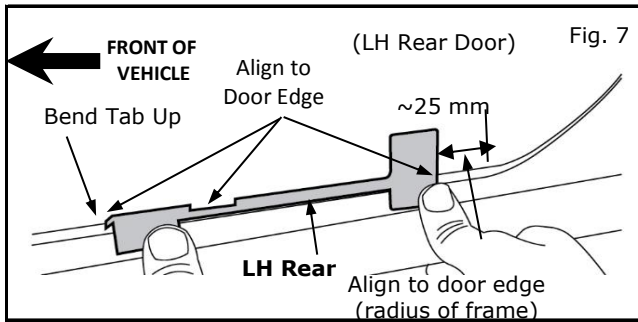

- 9) LH Rear template - Fold forward tab up and place template as indicated on rear door.
 10) Align template edges as shown with the rear door bottom edge.

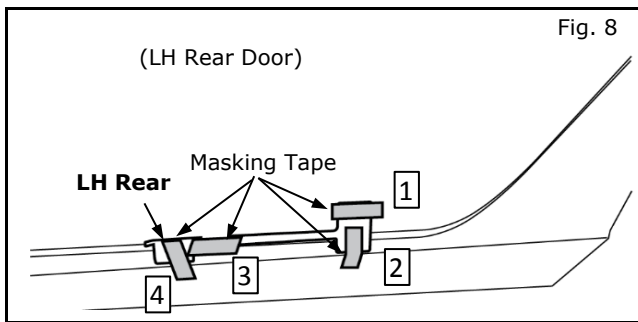

- 11) Secure Rear template with 1/2" masking tape in the locations & sequence shown.

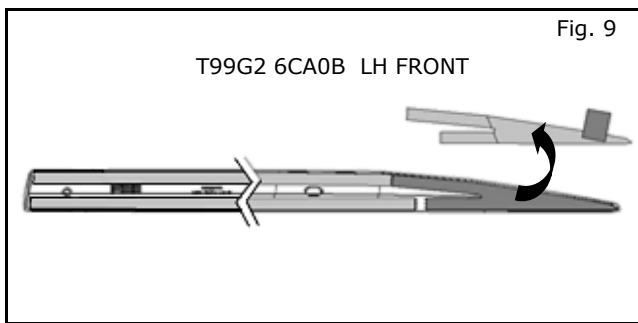

- 12) Remove die cut tape liner from front end of the Front Body Side Molding.

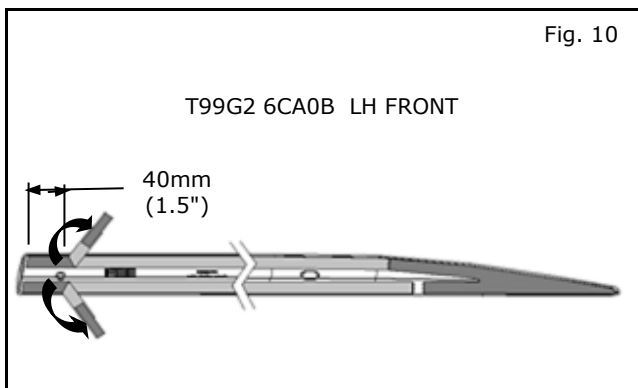

- 13) Peel back tape liner 40 mm (1.5") from rear end, as shown.

INSTALLATION PROCEDURE:

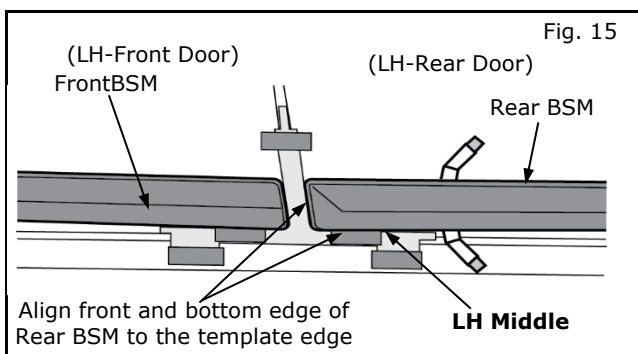
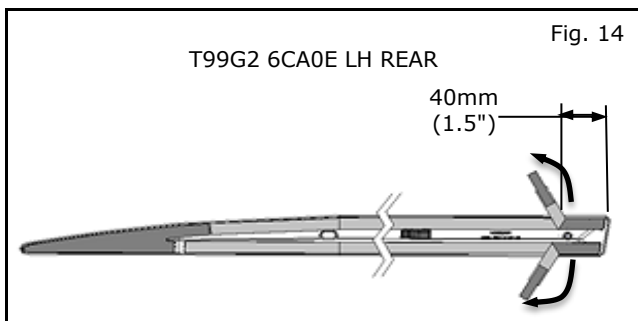
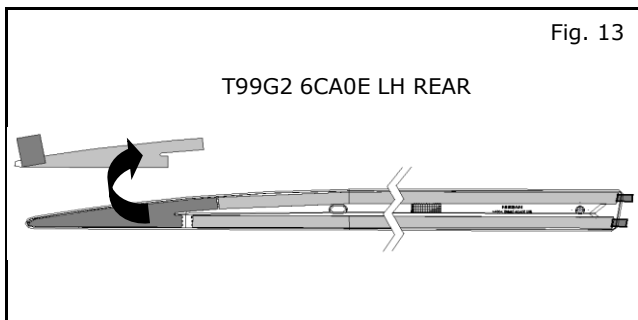
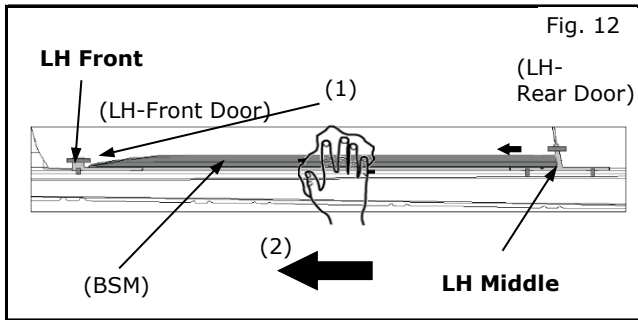
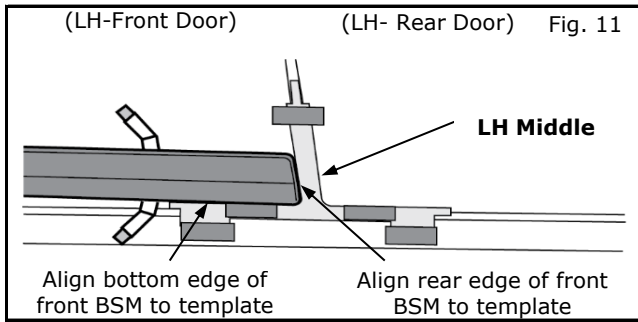

- 14) Align rear edge of Front Body Side Molding to the template edge as shown.
- 15) Align bottom edge of Front Body Side Molding to top edge of front template and press lightly into position. Slowly remove top & bottom tape liner from Body Side Molding. (See Fig. 12, Step 1)
Note: Re-grip every 3 inches when pulling liner to prevent tearing.
- 16) Apply 103kPa (15lbs) of pressure using a roller, or by hand with a clean rag from the rear, moving rear to front. (See Fig. 12, Step 2)
- 17) Remove die cut tape liner from end of Rear Body Side Molding.
- 18) Peel back tape liner 40 mm (1.5") from front end.
- 19) Align front and bottom edge of Rear Body Side Molding to the middle template edges as shown.

INSTALLATION PROCEDURE:

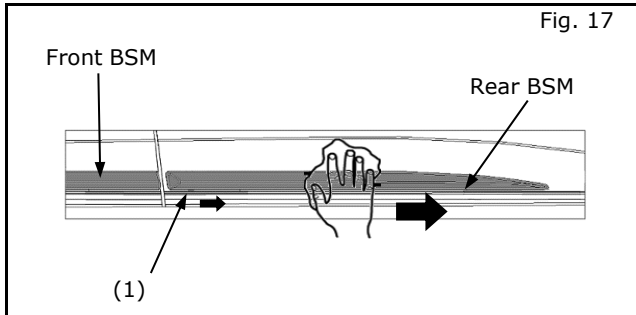
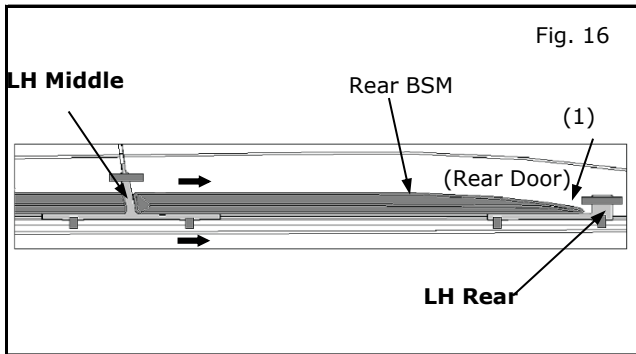

- 20) Align bottom edge of Rear Body Side Molding to top edge of rear template and press lightly into position. Slowly remove top & bottom tape liner from Body Side Molding.

Note: Re-grip every 3 inches when pulling liner to prevent tearing.

- 21) Remove and discard the templates.
- 22) Apply 103kPa (15lbs) of pressure using a roller, or by hand with a clean rag from the front, moving front to rear. (See Fig. 15, Step 2)
- 23) Repeat steps 1-22 for installation of Molding - RH Front Door & Molding- RH Rear Door on passenger side using RH installation template.