



GENUINE PARTS

INSTALLATION INSTRUCTIONS

DESCRIPTION:	Illuminated Kick Plate Kit
APPLICATION:	MAXIMA
PART NUMBER:	T99G6 4RA0A, T99G6 4RA0B - Illuminated Kick Plate Kit 999Q9 AY001 - Accessory Service Connector

KIT CONTENTS:

Item	Qty.	Part Description	Service Part Number
A	1	Illuminated Kick Plate, FR LH	Not Serviceable- Part of Kit T99G6 4RA0x
B	1	Illuminated Kick Plate, FR RH	
C	1	Kick Plate, RR LH	
D	1	Kick Plate, RR RH	
E	12	Cable Tie	
F	4	Foam Tape (Black)	
G	8	Foam Tape (Gray)	
H	4	Posi Tap	
I	1	Internet Website Address, paper, 999V2 AW000	
ITEMS NOT IN KIT THAT MAY BE REQUIRED			
J	2	Accessory Service Connector	999Q9 AY001

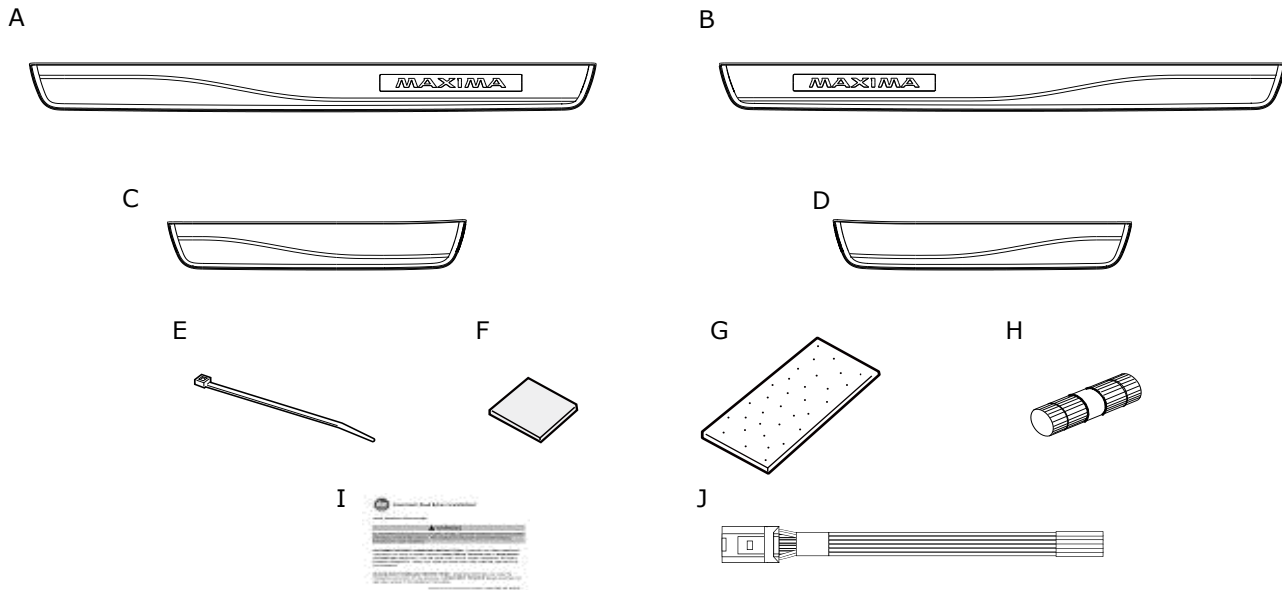

TOOLS REQUIRED:

- Nylon Trim Removal Tool
- Wire Cutter
- Flash Light
- Electrical Tape
- 50/50 Alcohol & Water Solution
- Soft Non-Linting Towel

Vehicle Preparation:

⚠ CAUTION

• Always confirm the ignition is in the "OFF" position before changing the switch condition.

- 1) Apply parking brake
- 2) Confirm vehicle is not in the default shipping state or "Inventory position" as shown below. Failure to confirm vehicle has been removed from this state will result in loss of normal vehicle operation.
- 3) Locate Extended Storage Switch in cabin fuse block. Confirm it is in the "Customer" position. See below for reference.
 - a) To remove transit mode (Fuse Block):
 1. Remove fuse cover lid.
 2. Push down shorting pin.
 3. Ign On 2 times without starting the vehicle.
 - b) To remove transit mode (BCM):
 1. Confirm ignition switch is in "OFF" position.
 2. Simultaneously push the signal and wiper switch fully down for two (2) seconds.

NOTE: While in BCM Transit Mode, turn signal indicators will remain illuminated for one minute.

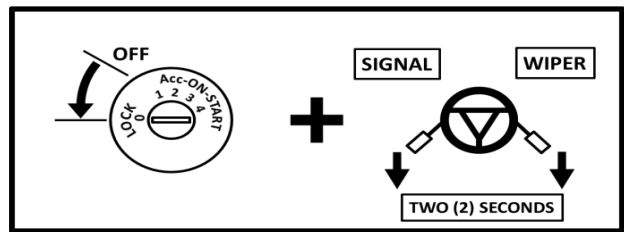
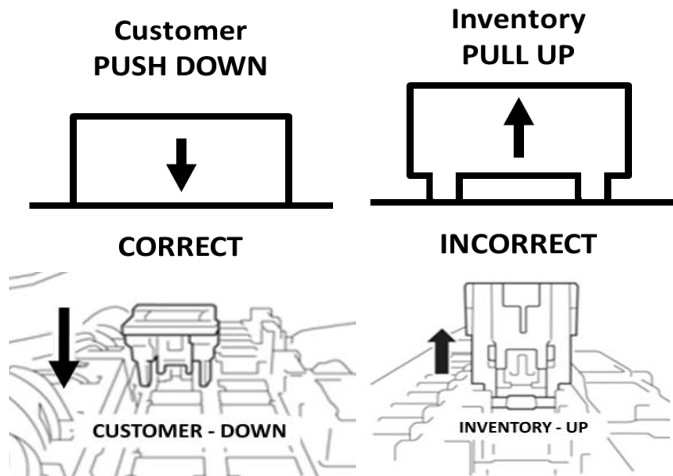

- c) To return to transit mode for storage:
 1. Ign Off.
 2. Remove fuse cover lid.
 3. Pull up shorting pin.
 4. Assemble fuse cover lid.
 5. Ign On 2 times without turn the vehicle on.
 6. Confirm transit mode condition on meter

NOTE: Typical vehicle condition shown above. Switch is easily identifiable by the permanent, push-pull fuse holder. Actual position on the fuse block may vary, vehicle to vehicle.

Condition	Switch Position	Note
Vehicle is delivered to the dealer	Inventory Condition	
Technician performs PDI	Customer Delivery	Return to Inventory position after PDI.
Customer test drives the vehicle	Customer Delivery	Return to Inventory position after test drive.
Vehicle is being stored at the dealer	Inventory Condition	
Vehicle is delivered to customer	Customer Delivery	

NOTE: The Extended Storage Switch is only an aid to improve battery life during vehicle storage at the dealer. If the Extended Storage Switch fuse ever needs service after vehicle delivery, discard the Extended Storage Switch and install the correct fuse in its place.

- 4) Turn ignition switch to "ON" position
- 5) Record the customer radio presets and other presets as required.

Preset	1	2	3	4	5	6		

- 6) Put shift lever in "P" position for A/T and CVT or "1st" for M/T
- 7) Turn ignition switch to "OFF" position
- 8) Use seat and floor protection.

INSTALLATION PROCEDURE: PRE-INSTALLATION CAUTIONS / NOTES

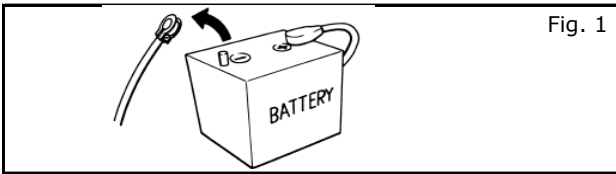

- 7) Disconnect the negative battery terminal.
- 8) Use seat and floor protection.
- 9) This part is to be installed at surface temperature of 65-100°F.

INSTALLATION OVERVIEW:

⚠ CAUTION

- Take care not to scratch or damage any component during the removal or re-installation process.
- Trim pieces found to have witness marks or broken clips are not to be reinstalled.

- 1) Remove the following vehicle parts in the sequence shown below. Store these re-usable parts in a safe and protected manner.

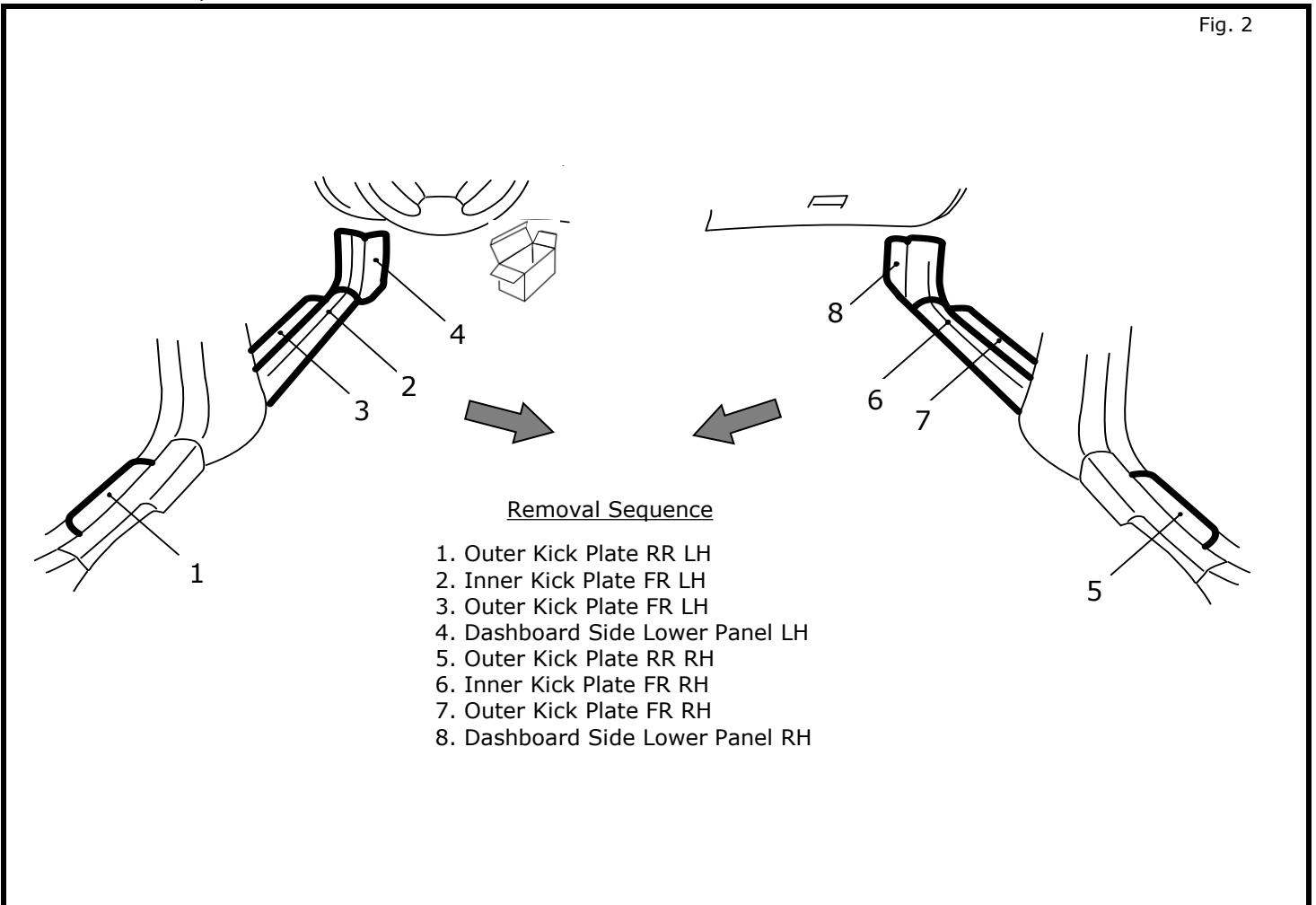

INSTALLATION OVERVIEW:

2) Installation Outline

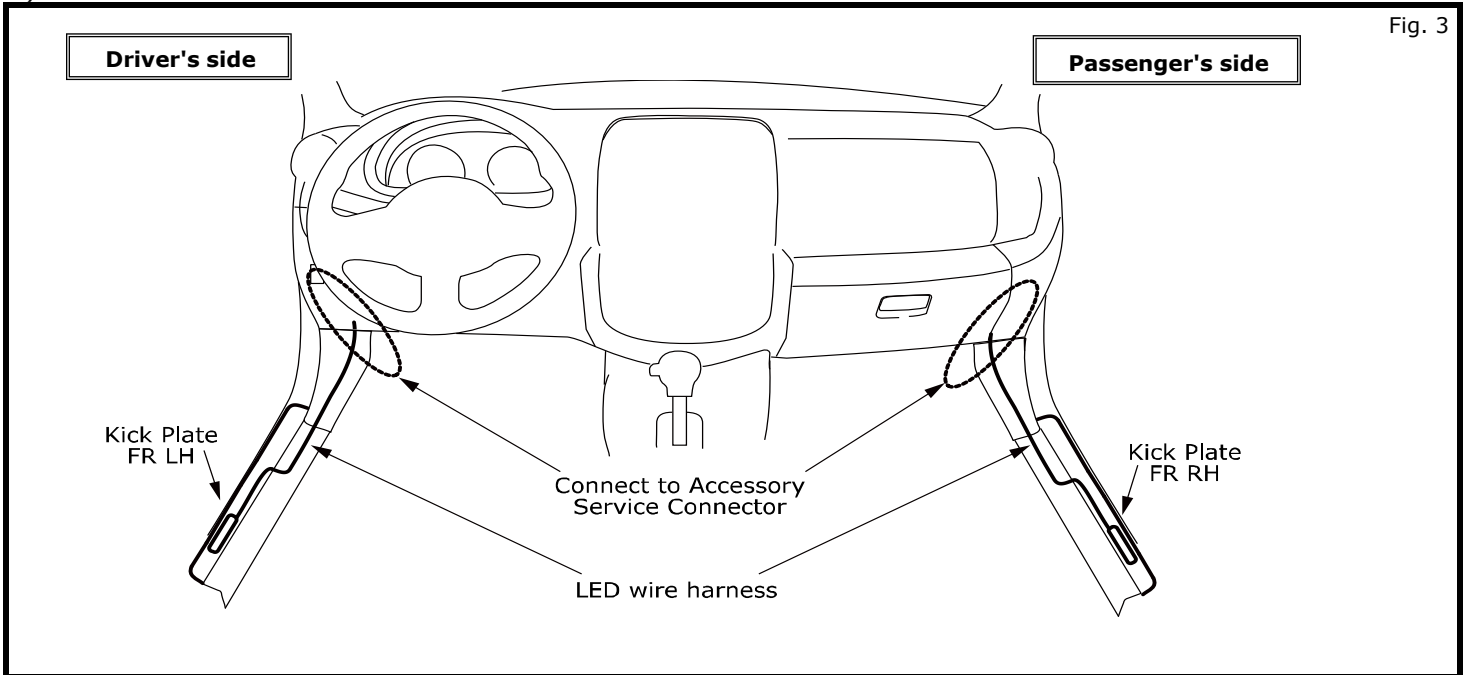

⚠ CAUTION

- Vehicle wiring color description is just for reference. Please refer to vehicle wiring diagram for details.

3) Kick Plate layout overview

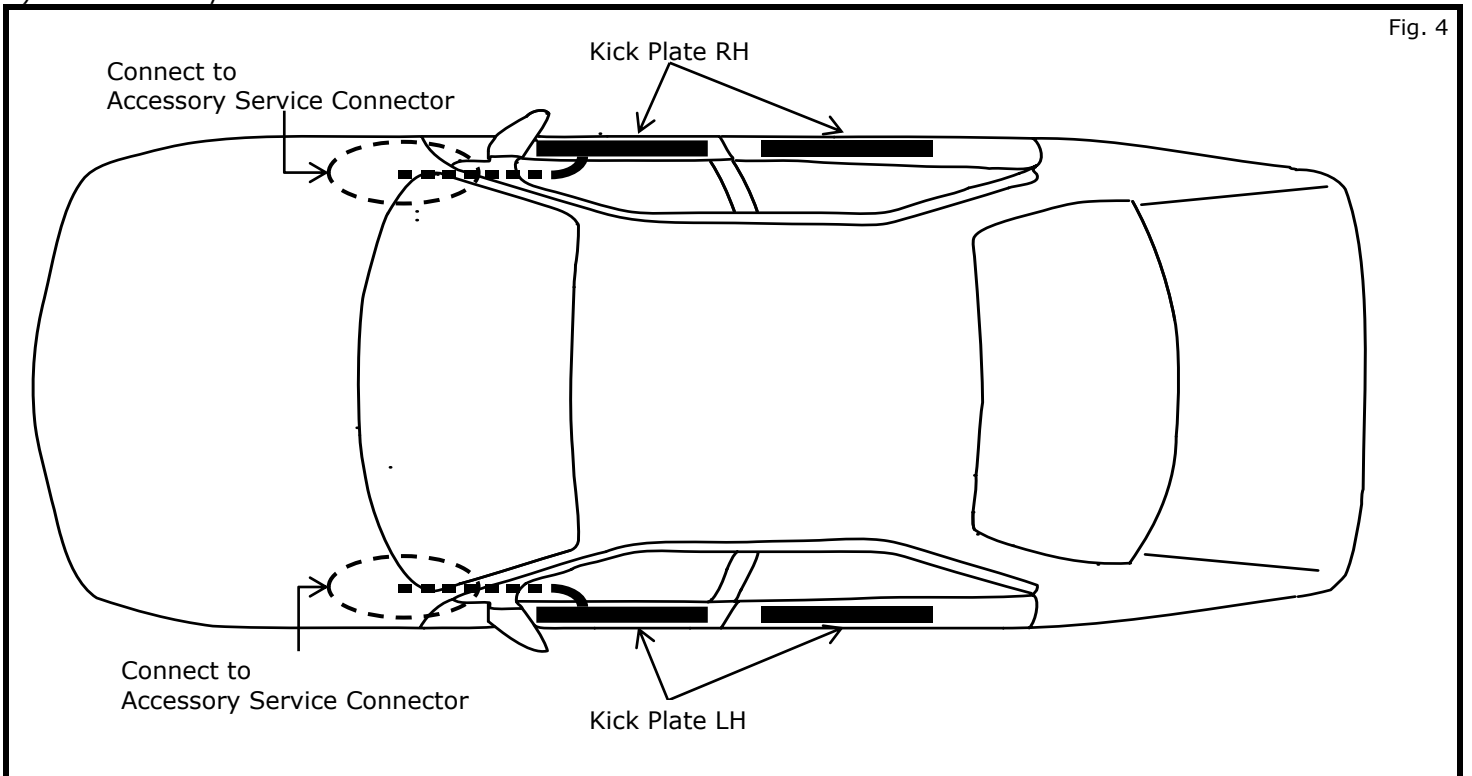

INSTALLATION PROCEDURE: VEHICLE PARTS REMOVAL

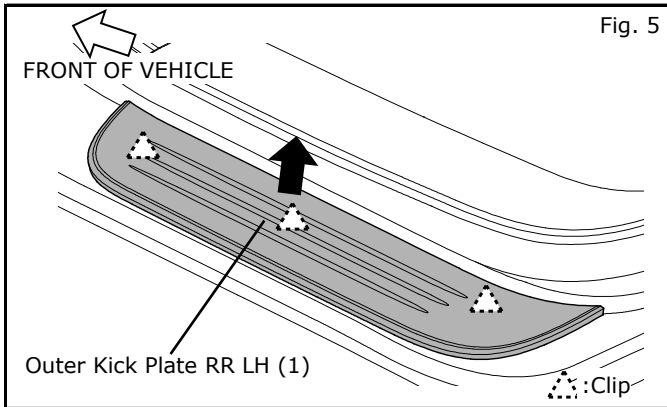

- 1) Outer Kick Plate RR LH (1) removal.
 - a) Remove Outer Kick Plate RR LH (1) by pulling straight up to disconnect clips as shown in Fig.5.

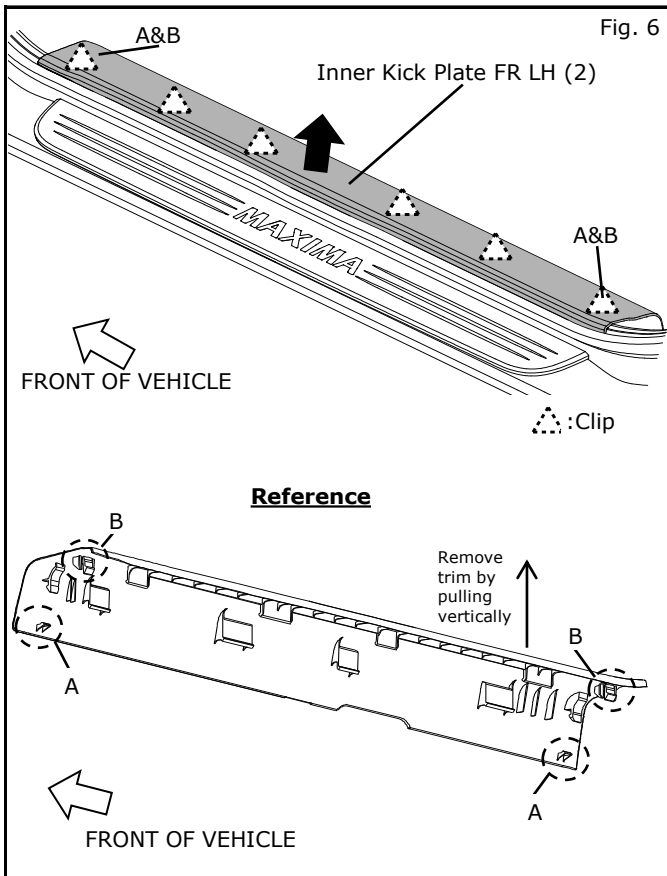

- 2) Inner Kick Plate FR LH (2) removal.
 - a) Remove Inner Kick Plate FR LH (2) by pulling straight up to disconnect clips as shown in Fig.6.

NOTE:

Place fingers at clip A which is located at inner rotating motion until clip A is popped loose then pull up to remove door sill trim panel.

NOTE:

Clips are located at locations labeled; A and B in Fig.6.

NOTE:

**Locations and orientations to avoid damage.
-PULL CAREFULLY-**

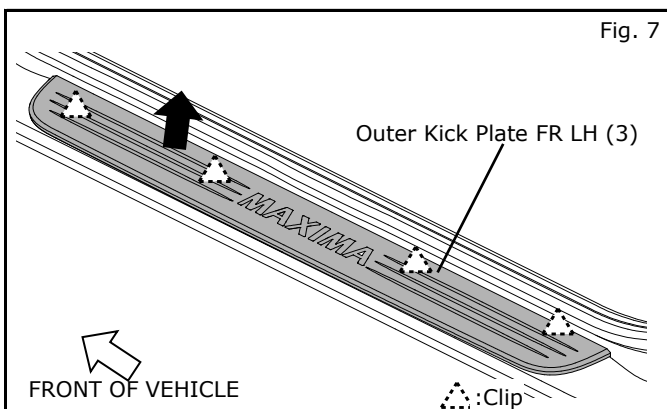

- 3) Outer Kick Plate FR LH (3) removal.
 - a) Remove Outer Kick Plate FR LH (3) by pulling straight up to disconnect clips as shown in Fig.7.

INSTALLATION PROCEDURE: VEHICLE PARTS REMOVAL

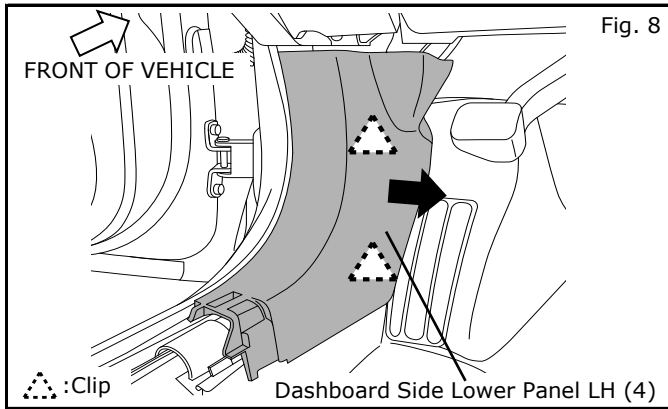

4) Dashboard Side Lower Panel LH (4) removal.

- a) Remove Dashboard Side Lower Panel LH (4) by pulling straight to disconnect clips as shown in Fig. 8.

5) Repeat steps 1 - 4 for right side parts of vehicle.

- Outer Kick Plate RR RH (5)
- Inner Kick Plate FR RH (6)
- Outer Kick Plate FR RH (7)
- Dashboard Side Lower Panel RH (8)

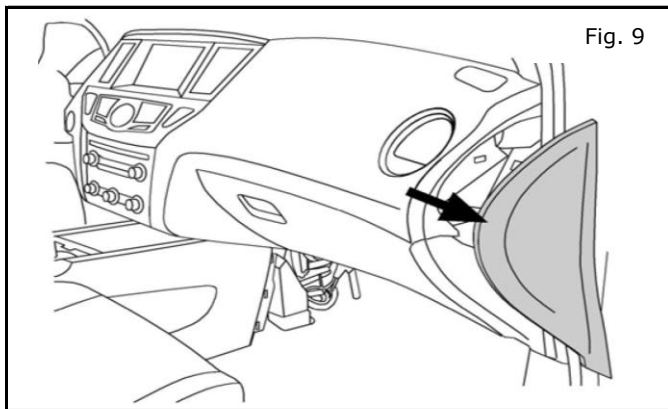

6) Passenger side dash mask removal.

- a) Carefully pry off passenger side dash mask as shown in Fig. 9.

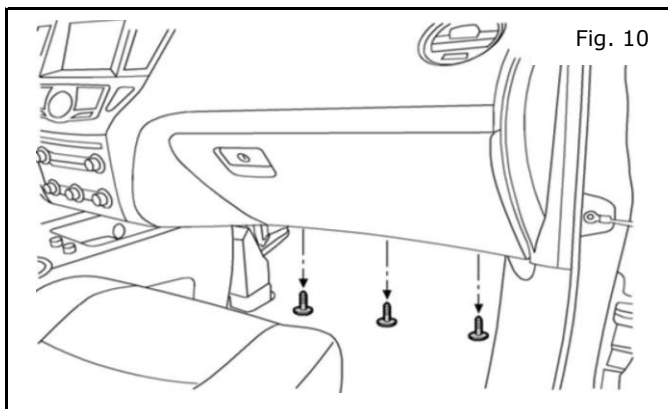

7) Glove box removal.

- b) Remove three (3) Phillips head screws from underside of glovebox as shown in Fig. 10.

INSTALLATION PROCEDURE: VEHICLE PARTS REMOVAL

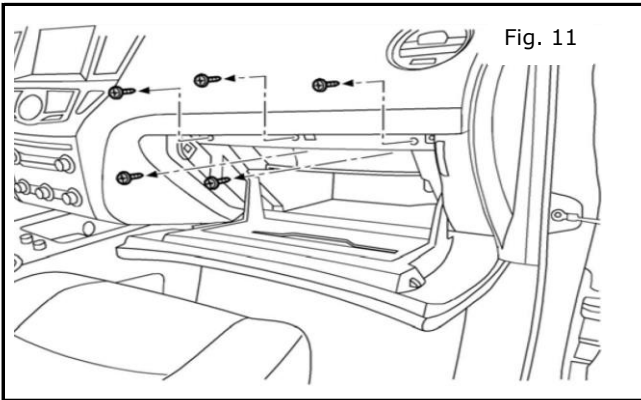

- b) Open glovebox door and remove five (5) phillips head screws from inside glovebox compartment as shown in Fig. 11.

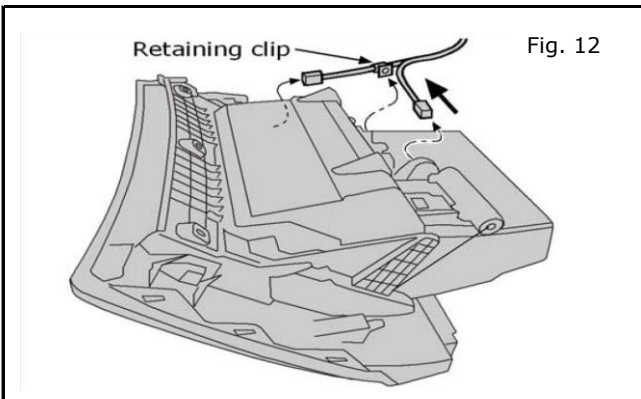

- c) Carefully pull glovebox assembly partially out, then gently detach clip and disconnect glovebox lamp as shown in Fig. 12. Once fully removed, set glovebox assembly aside.

INSTALLATION PROCEDURE: ILLUMINATED KICK PLATE INSTALLATION

NOTE: The procedure below shows the installation for LH side. Repeat procedure for RH side.

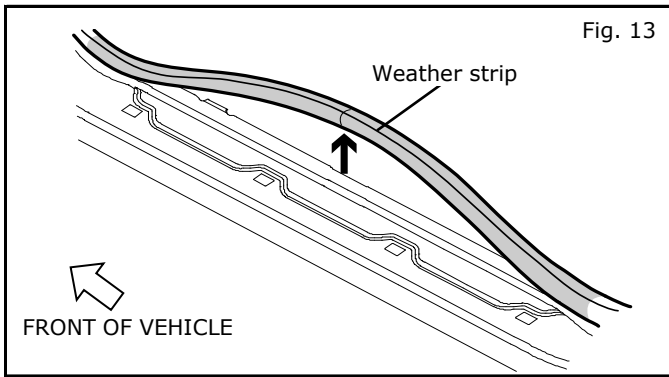

8) Remove vehicle weather strip as shown in Fig.13.

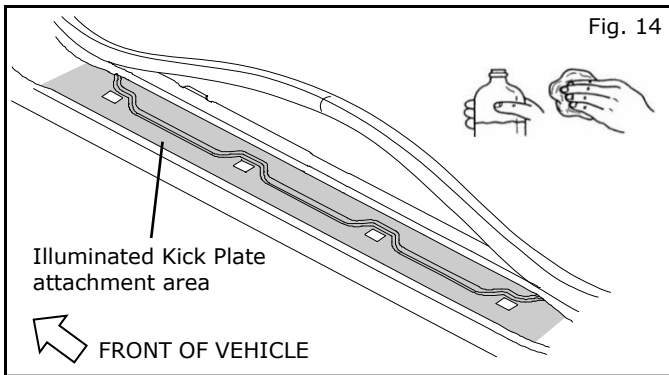

9) Clean Illuminated Kick Plate attachment area as shown in Fig.14 with 50/50 alcohol & water, let dry for 30 seconds.

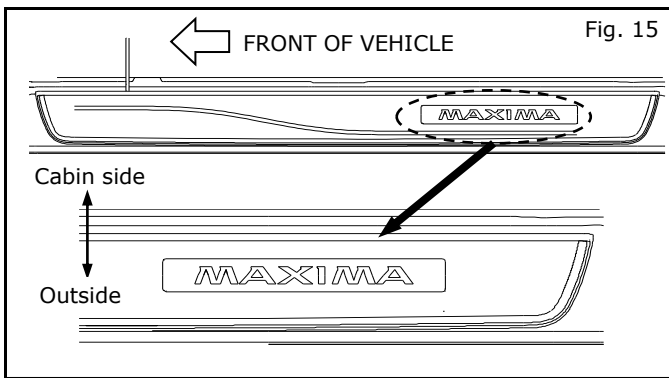

10) Logo should be readable from standing outside vehicle.

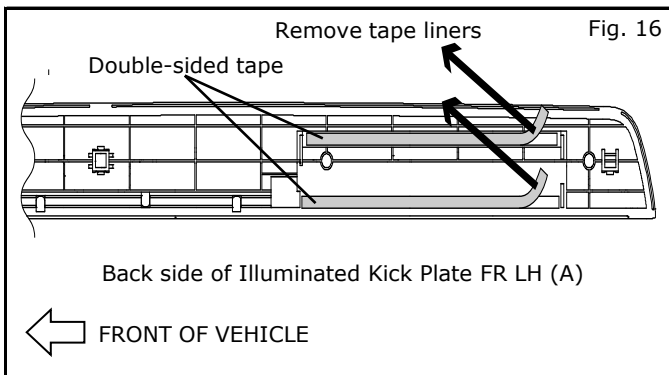

11) Remove tape liners of double-sided tape on backside of Illuminated Kick Plate FR LH (A) as shown in Fig.16.

INSTALLATION PROCEDURE: ILLUMINATED KICK PLATE INSTALLATION

NOTE: The procedure below shows the installation for LH side. Repeat procedure for RH side.

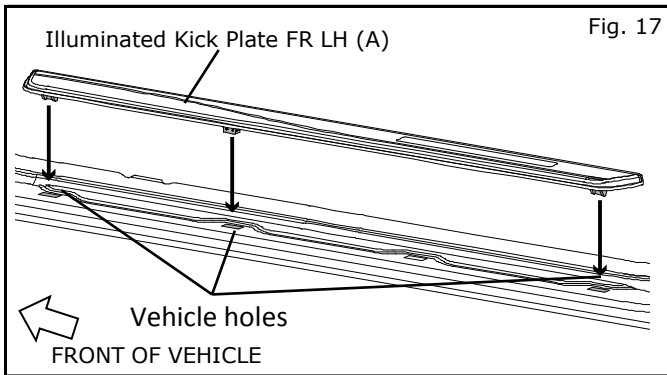

12) Align Location clips integrated on backside of Illuminated Kick Plate FR LH (A) to vehicle holes (first, second & fourth) as shown in Fig.17.

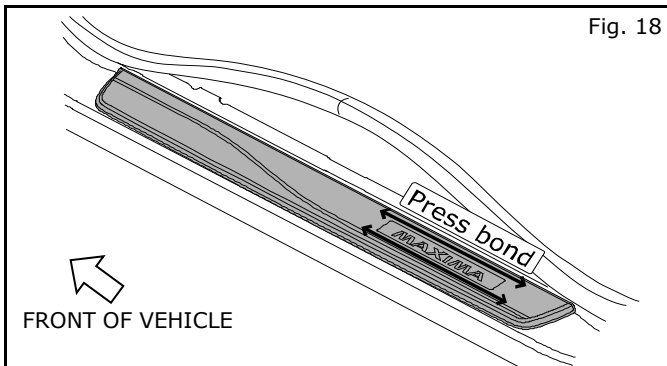

13) Insert clips to vehicle holes and push down to lock clips.

14) Apply minimum 11lb (49N) of pressure along the part to attach tape to body shown in Fig.18.

WARNING

- Use caution when applying pressure as the surface may dent.
- During installation, be careful not to allow the harness to get stuck between the vehicle and the kick plate.

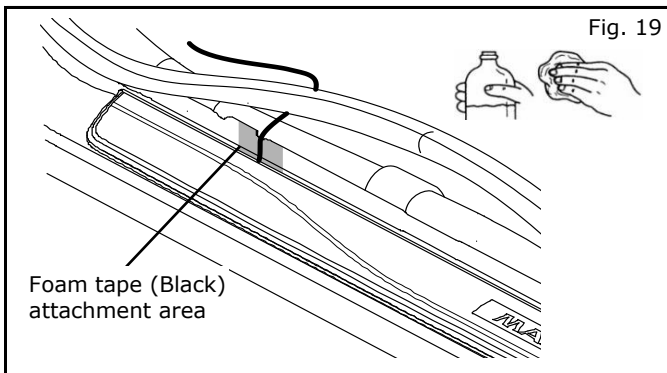

15) Clean both sides of attachment area for foamTape (Black) (F) with 50/50 alcohol & water, let dry for 30 seconds as shown in Fig. 19.

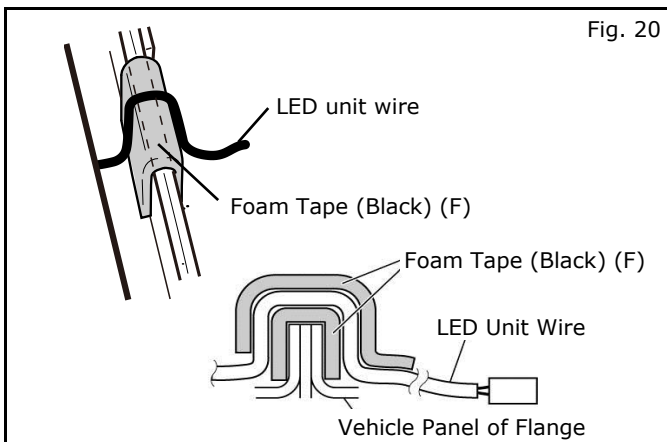

16) Paste a Foam Tape (Black) (F) over flange, making sure that it will not be visible once weathrestripping is replaced.

Then place LED unit wire on top of Foam Tape (Black) (F) as shown in Fig. 20.

Apply second Foam Tape (Black) (F) on top of LED unit wire as shown in Fig. 20.

INSTALLATION PROCEDURE: ILLUMINATED KICK PLATE INSTALLATION

NOTE: The procedure below shows the installation for LH side. Repeat procedure for RH side.

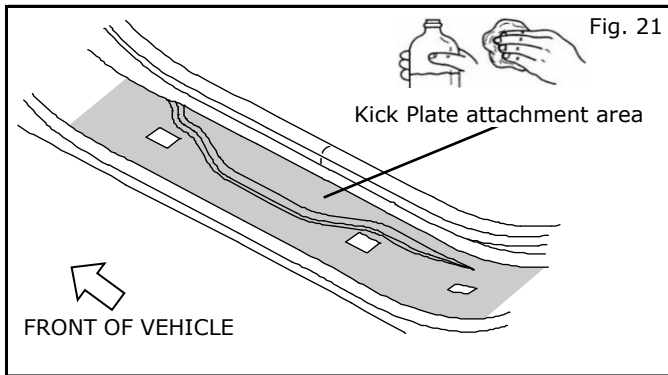

17) Clean Kick Plate attachment area as shown. with 50/50 alcohol & water, let dry for 30 seconds.

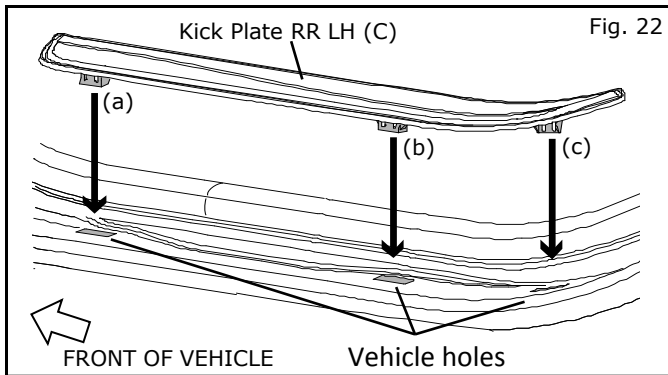

18) Align Location clips integrated on backside of Kick Plate RR LH (C) to vehicle holes as shown in Fig. 22.

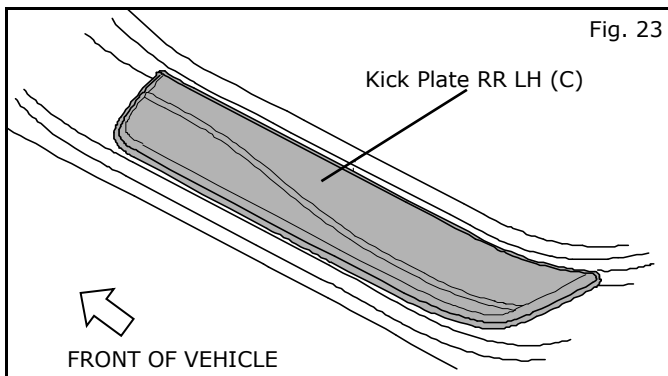

19) Insert clips to vehicle holes and push down to lock clips in order from (a) to (c) as shown in Fig. 22 & Fig. 23.

INSTALLATION PROCEDURE: LED UNIT WIRE INSTALLATION

NOTE: The procedure below shows the installation for LH side. Repeat procedure for RH side.

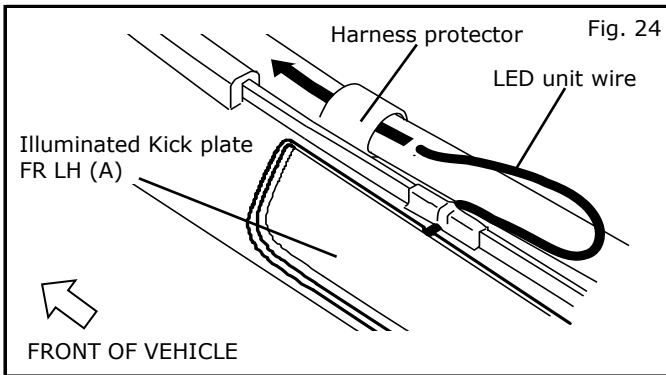

20) Route LED unit wire of Illuminated Kick plate FR LH (A) into harness protector as shown in Fig.24.

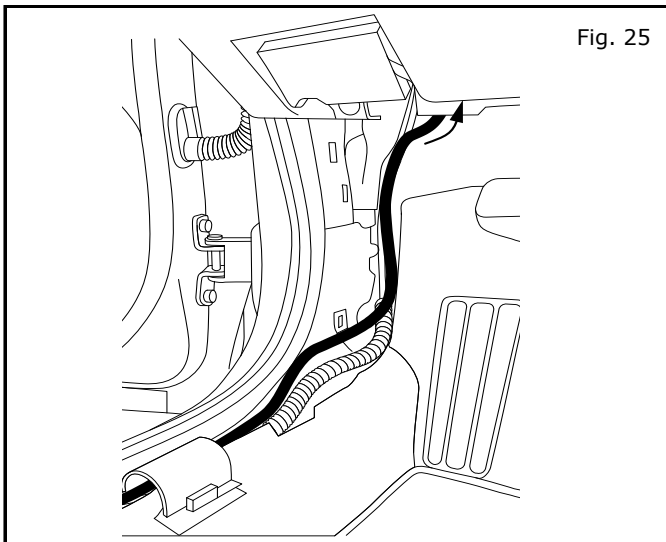

21) Route the LED unit wire of Illuminated Kick plate FR LH (A) to near the Accessory Service Connector as shown in Fig.25.

22) As shown in Fig. 26a; LH (ASC) is taped to harness as shown in Fig. 26b. RH (ASC) is taped as shown in Fig. 26c.

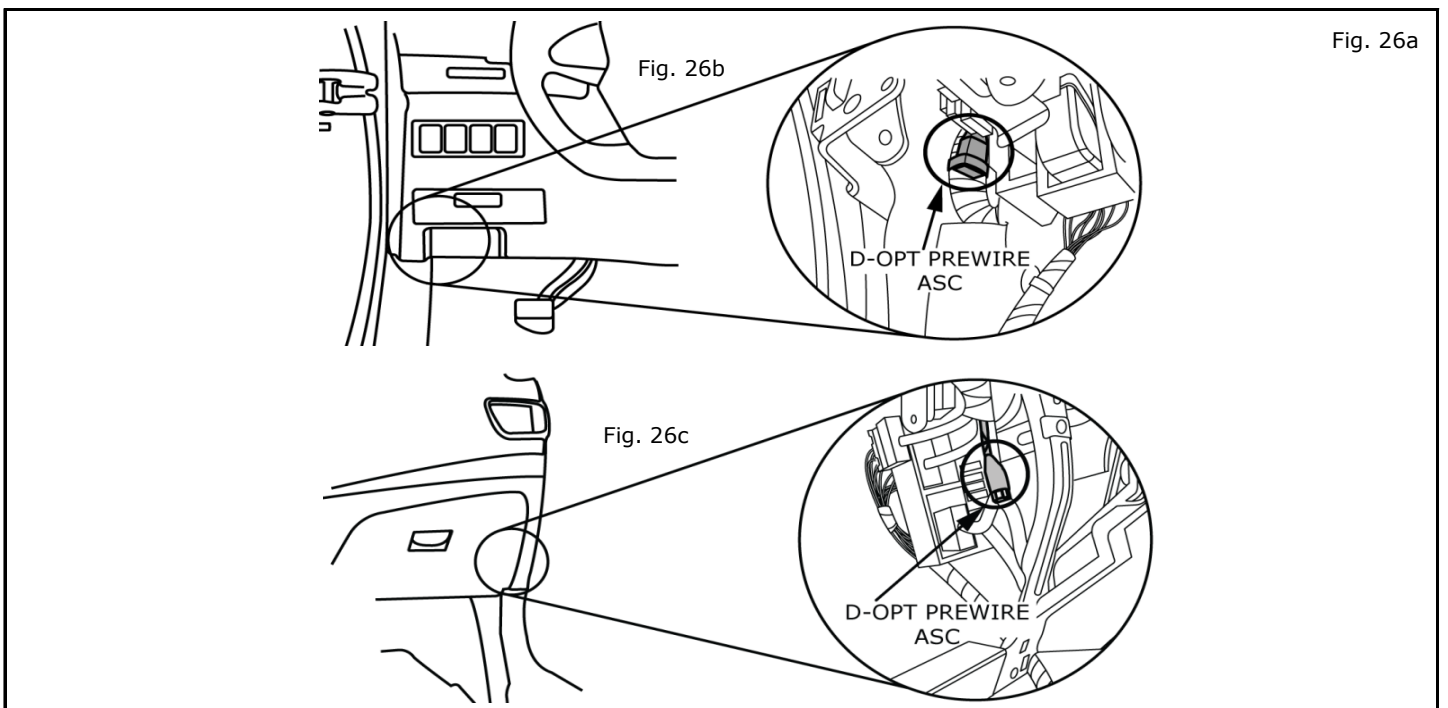

INSTALLATION PROCEDURE: LED UNIT WIRE INSTALLATION

CAUTION

This Accessory Service Connector is for use only with Genuine Nissan (or Infiniti) or Nissan (or Infiniti) approved accessories. Use of this connector with non Genuine Nissan (or Infiniti) or Nissan (or Infiniti) approved accessories or failure to follow the installation instructions for said connector being mentioned herein may result in damage to the accessory and/or your vehicle. Nissan (or Infiniti) is not liable for loss or damage due to improper installation or the installation of non Genuine or non approved accessories.

Fig. 27

Connecting side of ASC

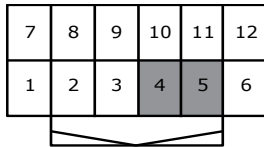

Pin location is referenced looking into face of connector. Refer to Mechanical Drawing on page 20.

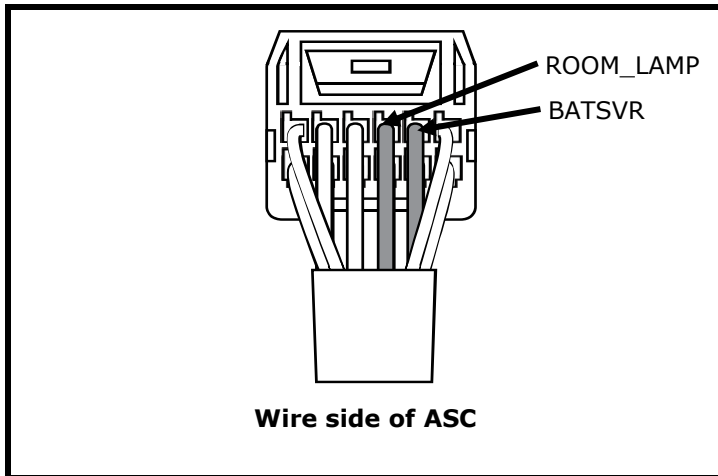

999Q9 AY001		
Pin	Label	Color
1	IGN	WHITE
2	BAT	RED
3	TL_LMP	PURPLE
4	RM_LMP	YELLOW
5	BATSVR	PINK
6	FR_DR_SW_RH	GRN
7	FR_DR_SW_LH	LT GRN
8	THRU_SIGNAL_1	GREY
9	RR_DR_SW_RH	BLU
10	RR_DR_SW_LH	LT BLU
11	ACC	ORANGE
12	GND	BLACK

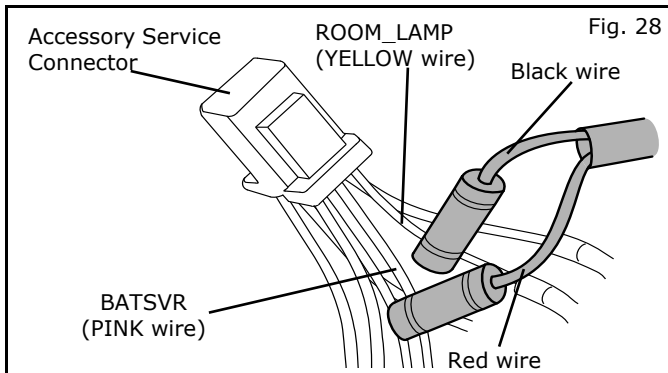

23) Using a Posi-Tap (H), connect the black wire of LED unit wire to the "ROOM_LAMP" (YELLOW wire) of the Accessory Service Connector as shown in Fig.28.

24) Using a Posi-Tap (H), connect the red wire LED unit wire to the "BATSVR" (PINK wire) of the Accessory Service Connector as shown in Fig. 28.

Note: Please refer to the next page for detailed information on Accessory Service Connector.

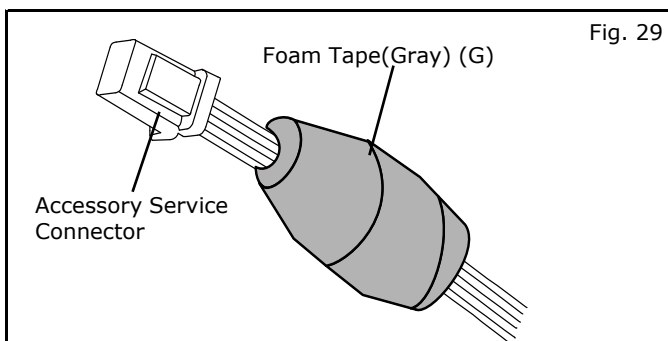

25) Wrap each Posi-Tap (H) with Foam Tape(Gray) (G) to prevent rattle.

26) Bundle the wrapped posi-taps with Foam Tape (Gray) (G) as shown in Fig 29.

27) Then plug the Accessory Service Connector into the vehicle harness.

POSI-TAP for the Accessory Service Connector ONLY.

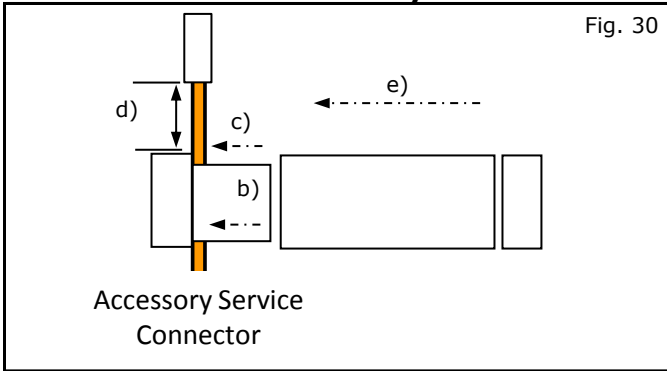

- 28) Tap Accessory service wire.
- Identify and confirm correct wire in the Accessory Service Connector to be tapped.
 - Remove cap (slot side) from tap body.
 - Slide cap around single accessory wire.
 - Position cap $\geq 6.35\text{mm}(0.25\text{in})$ away from the heat shrink end of Accessory Service Connector. (Measurement for first posi-tap installed on the circuit.)
 - Tighten the tap **TIGHT** with finger pressure.
 - Tighten by another quarter turn.

NOTE: Figures are not to scale.

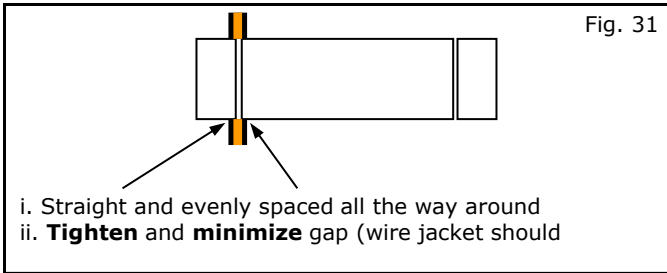

- 29) Inspect the tap to ensure correct installation.
- Pull on the wire lightly to ensure connection.
 - Inspect the tap to ensure correct installation.
 - Test the signal to ensure that it is working properly.

NOTE: Avoid putting pressure on the vehicle wire and tap for the remainder of the installation.

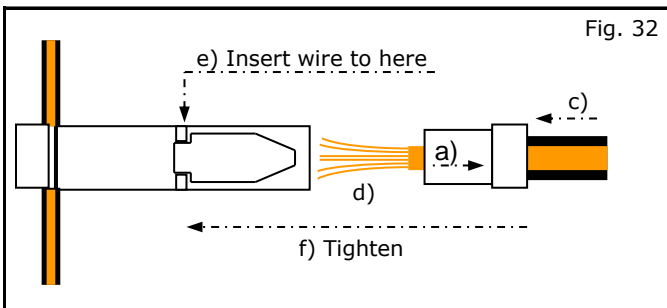

- 30) Tap accessory wire.
- Remove tap (non-pierce) side from tap.
 - Remove the protective stub from the wire.
 - Insert wire through the non-pierce side opening.
 - Spread the individual strands into fan shape.
 - Insert wire into the tap body and ensure that it is all the way in.
 - Tighten the tap **TIGHT** with finger pressure.
 - Tighten by another quarter turn.

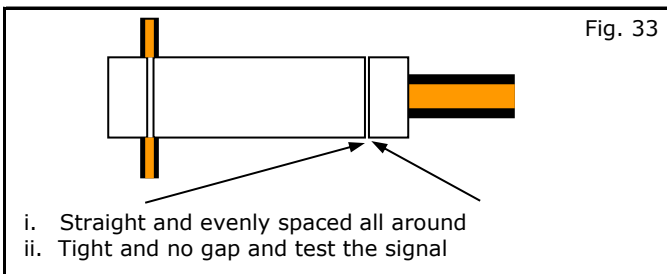

- 31) Confirm the tapped accessory wire.
- Pull on the wire lightly to ensure connection.
 - Inspect the tap to ensure correct installation.
 - Test the signal to ensure that it is working.

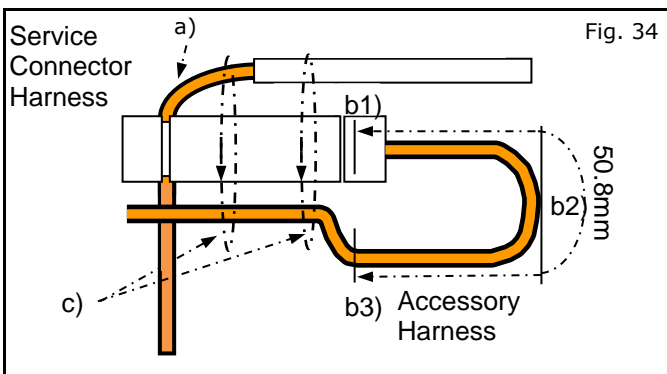

- 32) Forming strain relief loop (always required)
- Gently bend the end of the pierced wire (where it exits the cap) down towards body of Posi-tap.
 - On the tapped wire of the non-pierce side; starting at point b1), measure 50.8mm (2in) to point b3). Make the first bend of the loop b2), half the distance measured 25.1mm (1in), and up towards the body of the posi-tap, make the second bend of the loop b3) in towards the posi-tap so it can be secured with electrical tape.
 - Secure the pierced wire on the heat shrink side and the tapped wire on the non pierce side to the body of the tap with electrical tape (≥ 2 revolutions).

IF securing multiple posi-taps on a single circuit.

NOTE: If securing multiple taps to single circuit continue to Step 6, if tapping different circuits repeat steps 1-5 as required, then proceed to step 10.

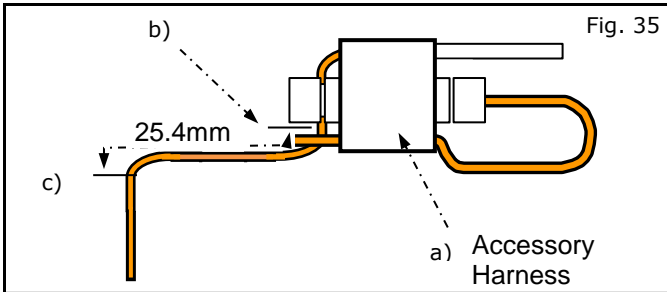

- 33) Multiple posi-taps on the same wire; first tap
- a) The first accessory is tapped, relieved and secured as shown in Fig 25 thru 29. (these steps are always the same)
 - b) Measure 25.4mm(1in) from point b) to point c) on the pierced wire.
 - c) At points b) & c), bend the pierced wire gently to form the "staircase" shape.

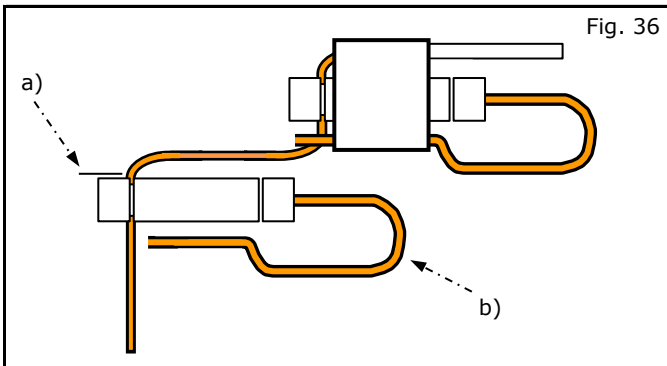

- 34) Multiple posi-taps; second accessory.
- a) Tap second accessory at point b), making sure to preserve "staircase shape".
 - b) After tapping second accessory, form a strain relief loop for the tapped wire on the non-pierce side as shown in Fig c) and detailed in step 5b.

NOTE: Do not secure before reading step 8. Repeat as necessary.

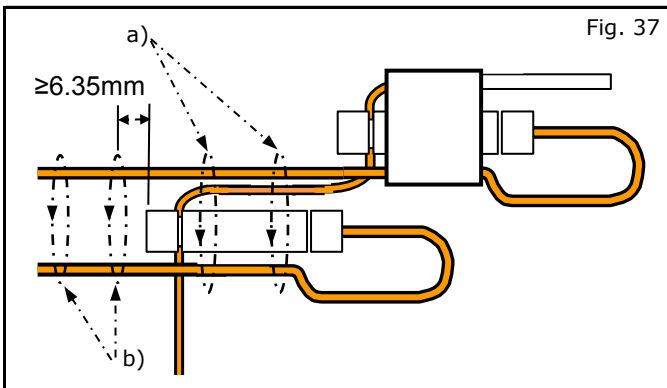

- 35) Securing multiple posi-taps on the same circuit
- a) Secure the pierced and tapped wires from the first posi-tap, along with the tapped wire from the non pierce side of the 2nd posi-tap to the body of the 2nd tap with electrical tape (≥ 2 revolutions).
 - b) Secure the tapped wires from the non-pierced sides of each tap to each other with electrical tape (≥ 2 revolutions) at a distance of $\geq 6.35\text{mm}$ (0.25in) from the head of last posi-tap shown in Fig b).

NOTE: Repeat as required.

NOTE: No single wire should be posi-tapped more than 4 times to maintain integrity.

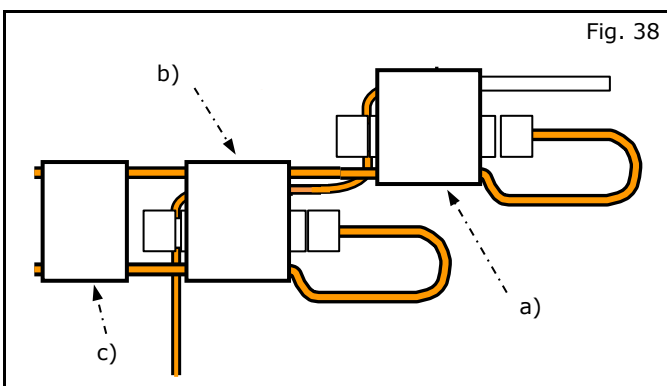

- 36) Multiple accessory taps on the same circuit secured.
- a) The first accessory is tapped, relieved and has the pierced wire on the heat shrink side and the tapped wire on the non-pierce side secured to the first tap as shown in Fig a).
 - b) The second accessory is tapped, relieved and has the pierced wire, the tapped wire on the non-pierce side and the tapped wire from the non-pierce side of the first posi-tap secured to the second tap as shown in Fig b).
 - c) Finally the tapped wires on the non-pierce side of the first and subsequent posi-taps are secured to each other as shown in Fig c).

Securing multiple tapped wires together.

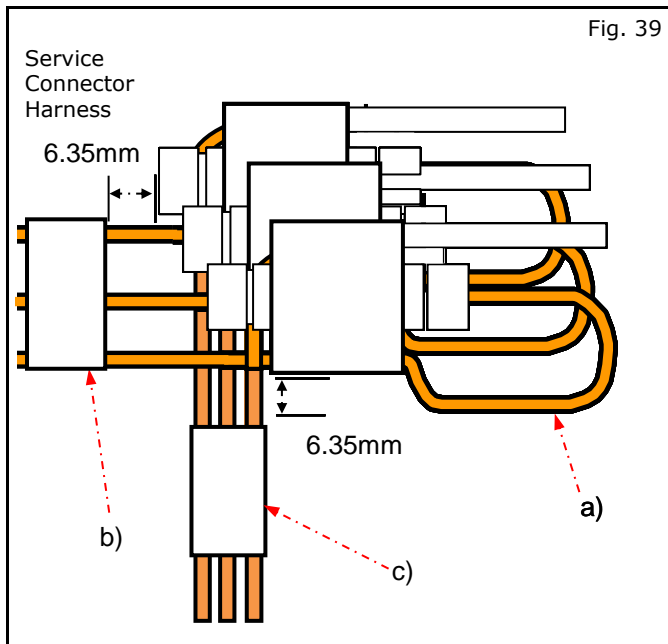

37) Multiple accessory taps on different circuits secured together.

- The tapped accessories (with wires already secured to tap bodies) are stacked slightly staggered on top of each other as shown in Fig a).
- The tapped wires on the non-pierce side of all the posi-taps are secured to each other with electrical tape (≥ 2 revolutions) at a distance of $\geq 6.35\text{mm}$ (0.25in) as shown in Fig b).
- The pierced wires of the first and subsequent posi-taps are secured to each other with electrical tape (≥ 2 revolutions) at a distance of $\geq 6.35\text{mm}$ (0.25in) as shown in Fig c).

INSTALLATION PROCEDURE: LED UNIT WIRE INSTALLATION

NOTE: The procedure below shows the installation for LH side. Repeat procedure for RH side.

Fig. 40

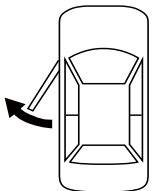
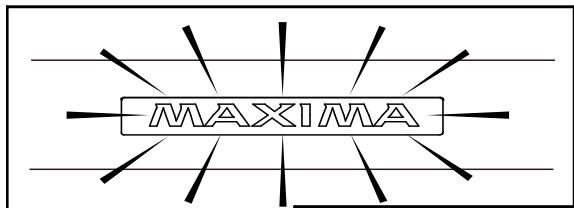

38) Function check

a) Connect battery.

b) Check function. Confirm LH/RH "MAXIMA" text is illuminated when LH/RH door is in open position. Manually engage door switch to verify Illuminated Kick Plate turns OFF as shown in Fig. 40.

c) If NG, check LED unit wire routing, connections to Accessory Service Connector and LED unit to identify root cause.

INSTALLATION PROCEDURE: LED UNIT WIRE INSTALLATION

NOTE: The procedure below shows the installation for LH side. Repeat procedure for RH side.

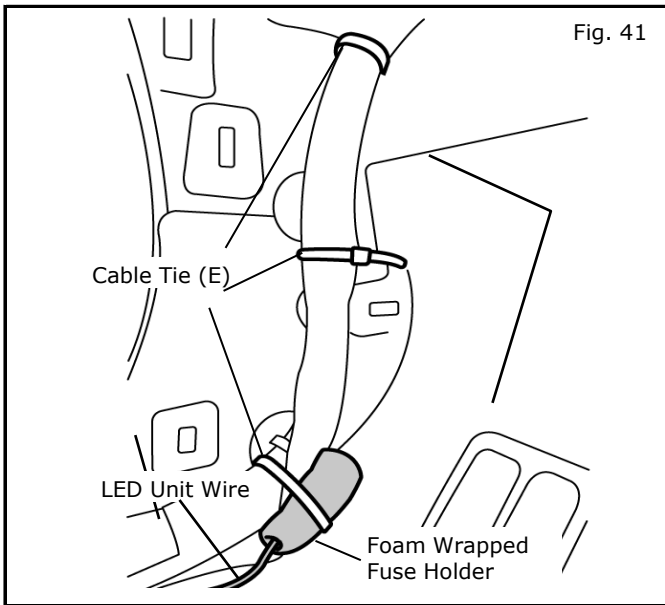

⚠ CAUTION

- Do not attach the harness to sharp metal edge.

- 39) Secure posi-tap bundle to vehicle harness with 1 Cable Tie .
- 40) Wrap fuse holder with Foam Tape(Gray) to prevent rattle as shown in Fig.41.
- 41) Secure LED unit wire to vehicle harness with 3 Cable Ties as shown in Fig.41. One cable tie should wrap around fuse holder.
- 42) Secure excess LED unit wire to vehicle harness with 2 Cable Ties as shown in Fig.42

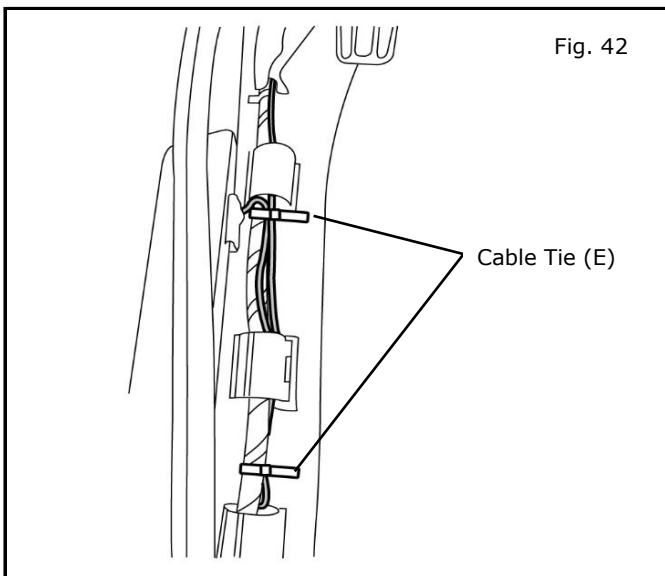

ACCESSORY CHECK: (Must for any accessory that uses the vehicle battery for power)

- Connect the battery negative terminal and tighten the nut to 5.4 N-m (47.8 lb-in)
- Check all Critical Installation Steps.
- Check all torque values. (Reference related steps and figures)
- Verify all wiring is secure and not exposed.
- Trim all excess cable ties flush.

RE-INSTALLATION OF REMOVED PARTS:

- Re-install all removed vehicle parts. Refer to the vehicle service manual as necessary.
 - Reinstall glove box and passenger side dash mask.
 - Reinstall the Dashboard Side Lower Panel LH and RH. Be very careful not to damage the clips while inserting in the A-Pillar. (See Fig.A)
 - Reinstall both the Sill Kick Trim being very careful that the vertical oriented tabs are aligned with the clips on the wire harness retainers. (See Fig.B & Fig.6, page5.)

⚠ CAUTION

Use caution when re-installing interior components to avoid damage, scratches, or breaking of mounting clips. Refer to the vehicle service manual for more information.

- Clean interior of vehicle.

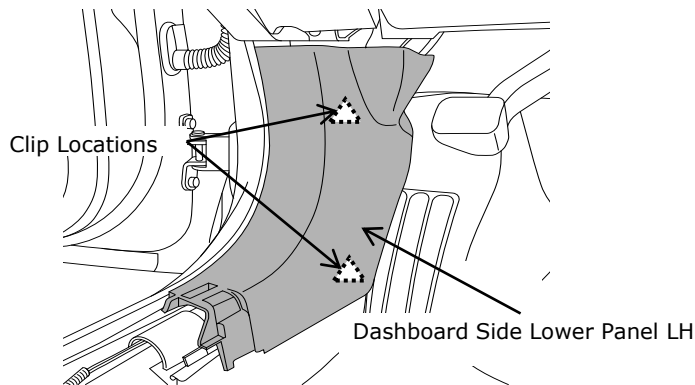

Fig. A

FINAL INSPECTION:

- Verify re-installed trim parts for proper flush fit (no gap, no waviness, etc.).
- Verify re-installed weather stripping for proper flush fit (no waviness, etc.).
- Verify all clips are fully engaged and locked.
- Verify re-installed trim parts are free from cracks, scratches or stress marks.
- Verify vehicle headliner, seat, steering wheel, center console, floor carpets, etc. are not soiled.
- Verify interior and exterior is not damaged.
- Start engine and verify that there are no new Diagnostic Trouble Codes. Turn ignition switch to "OFF".
- If this vehicle will be returned to a dealer lot or showroom, always place the extended storage switch in the "inventory" position. Refer to the Extended Storage Switch verbiage at the beginning of the 'INSTALLATION PROCEDURE' section.**
- Re-program radio presets and other vehicle settings to the recorded settings. No need to do this step if the extended storage switch is placed in the "inventory" position.

CAUTION

- Do NOT step on kick plate or wash vehicle for 24 hours after installing to prevent the double-sided tape from peeling.
- When turn off the ignition switch, do NOT let the door opening for long time, or else electrical source can be used up.

NOTE:

Posi-Tap™ is protected by patent # 5,228,875 5,695,369 5,868,589 6,692,313 Jap 2881414 Aus 708700 Tia 103534 Can 2204826 Mex 200626 Korea 477279 China Z197105562.9 & others pending.

ILLUMINATED KICK PLATE

ACCY_SER_CONN

IGN	1
BAT	2
TAIL_LAMP	3
ROOM_LAMP	4
BAT_SAVER	5
FR_DOOR_SW_RH	6
FR_DOOR_SW_LH	7
THRU_SIGNAL_1	8
RR_DOOR_RH	9
RR_DOOR_LH	10
ACC	11
GND	12

White

Red

Purple

Yellow

Pink

Green

LT Green

Gray

Blue

LT Blue

Orange

Black

TH12FW-NH

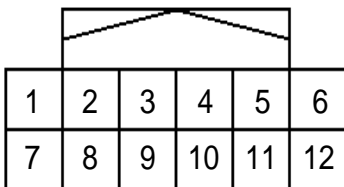

Note: Pin location is referenced looking into wire side of connector.

ILLUMINATED KICK PLATE

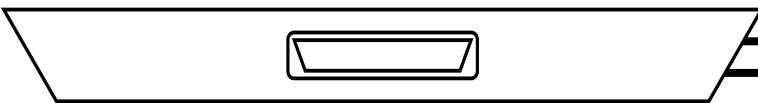

Red

Black

Legend

Posi tap

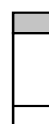

Gray

Red