



GENUINE PARTS

INSTALLATION INSTRUCTIONS

1. DESCRIPTION: SIDE WINDOW DEFLECTOR

2. APPLICATION: FRONTIER KING CAB/CREW CAB

3. PART NUMBER: 999D3 BT000KC, 999D3 BT001CC

4. KIT CONTENTS

Item No.	Qty		Description
	KING CAB 999D3 BT000KC	CREW CAB 999D3 BT001CC	
1)	1	1	Side window deflector, front, driver side
2)	1	1	Side window deflector, front, passenger side
3)		1	Side window deflector, rear, driver side
4)		1	Side window deflector, rear, passenger side
5)	2	2	Bracket A (Stamped "A")
6)	2	2	Bracket B (Stamped "B")
7)	2	2	Bracket C (Stamped "C")
8)		4	Bracket D (Stamped "D")
9)	6	10	Plastic rivet
10)	2	4	Isopropyl alcohol pads
11)	1	1	Paper template

5. TOOLS REQUIRED:

- masking tape
- scissors
- soap/water
- clean towel
- Hot Air Blower

6. INSTALLATION PRECAUTIONS / NOTES:

- The deflectors are mounted on the OUTSIDE surface of the door frame.
- The ideal ambient temperature for installation is above 60°F (15°C).
- Do not drive vehicle for one hour after installation.
- Avoid contact with moisture and washing vehicle for 24 hours after installation.
- Once the Side window deflector has been attached to the vehicle with the double-sided tape, do not peel it off again. Doing so will weaken the adhesive, lowering its intended bonding strength. Make sure that the Side window deflector is positioned properly before attaching it so that you will not have to make adjustment later.

INSTALLATION INSTRUCTIONS - SIDE WINDOW DEFLECTOR

7. INSTALLATION PROCEDURE

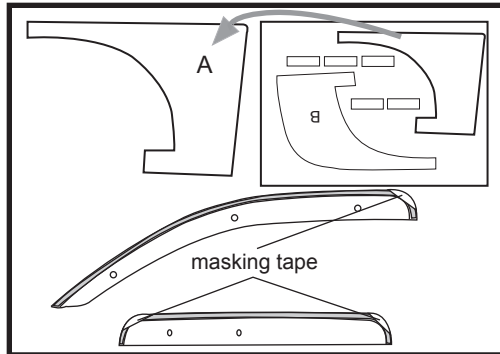

- 1) Cut out all templates.
- 2) Carefully remove masking tape from corners of deflector.
Note: DO NOT REMOVE TAPE LINERS.
- 3) Open window.

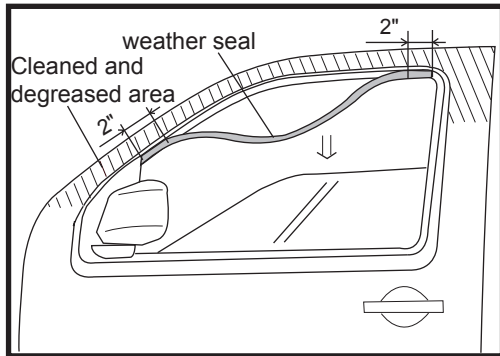

- 4) Remove weather seal except for section 2" from corners (see illustration).
- 5) Using soap and water, clean the surface where the deflector will be mounted. Once the surface is dry, wipe down with an alcohol pad.

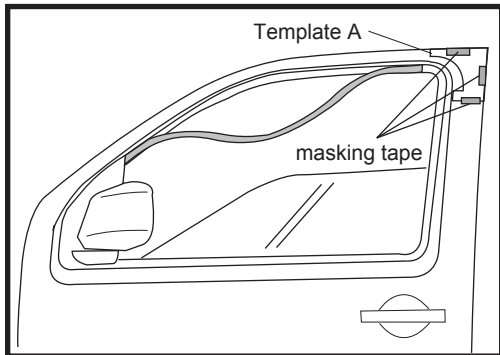

- 6) Align edges of template A with door panel edges as shown in illustration and secure with masking tape.

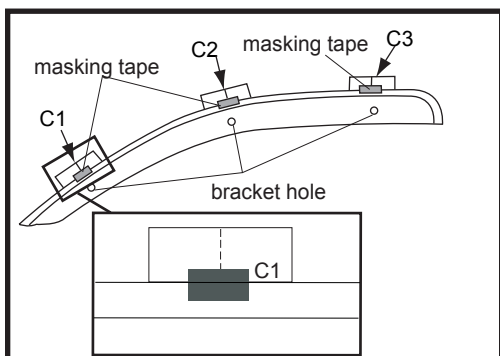

- 7) Align centerline of templates C1, C2 and C3 to the three bracket holes and tape them flush to the deflector (see illustration).

INSTALLATION INSTRUCTIONS - SIDE WINDOW DEFLECTOR

7. INSTALLATION PROCEDURE

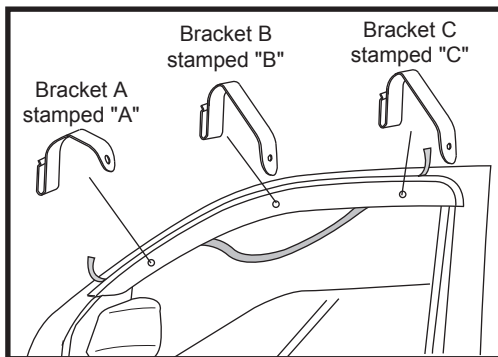
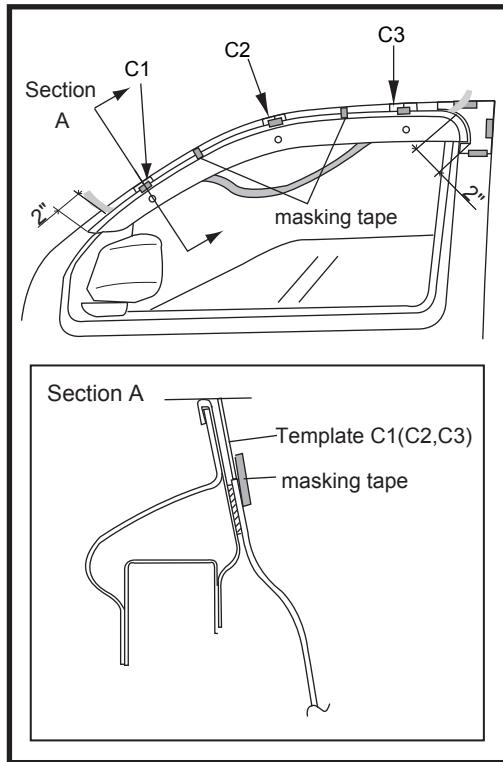

8) The surface temperature where the deflector will be mounted should be at least 60° F or 15° C for proper start-up adhesion of the tape. Use a hot air blower if the temperature is below 60° F.

9) Peel off 2" of tape liner from the front and rear ends of flange.

10) Align deflector to template A and align edge of templates C1,C2, and C3 to edge of door frame (see section A).

11) Temporarily fix the deflector to the door using masking tape.

12) Lightly press the exposed areas of tape to secure and verify position.

13) Install bracket A,B, and C onto door flange aligned with the deflector holes.

INSTALLATION INSTRUCTIONS - SIDE WINDOW DEFLECTOR

7. INSTALLATION PROCEDURE

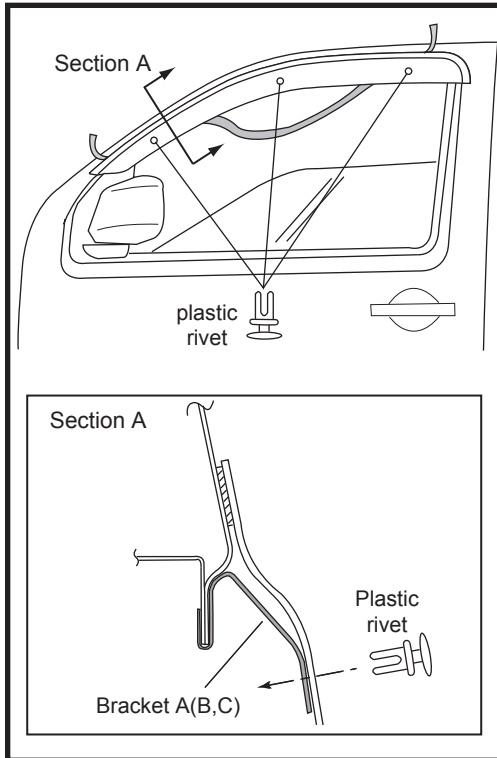

14) Fasten the deflector to brackets using plastic rivets.

15) Carefully remove all templates.

IMPORTANT
DO NOT TEAR OR DAMAGE THE TEMPLATES. ALL TEMPLATES ARE REUSED FOR PASSENGER SIDE INSTALLATION.

16) Remove and discard the remaining strips of masking tape.

17) Remove the remaining tape liner by pulling on the free end from front to rear.

18) Apply by hand a minimum of 15 lbs. of pressure on the deflector flange along the length of the tape.

19) Reinstall weatherseal to the original position.

20) Operate door window open / close to confirm its operation.

Repeat steps 1 - 20 for passenger side.

INSTALLATION INSTRUCTIONS - SIDE WINDOW DEFLECTOR

7. INSTALLATION PROCEDURE

Important

**Driver and passenger rear deflector identification:
Holes are located nearer to the front edge.**

Steps are for CREW CAB only.
Rear deflector preparation:

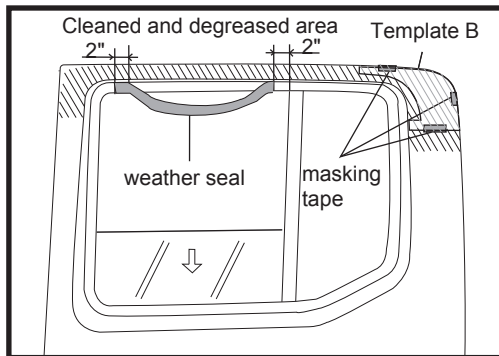

- 1) Open window.
- 2) Remove weather seal except for section 2" from corners (see illustration).
- 3) Using soap and water, clean the surface where the deflector will be mounted. Once the surface is dry, wipe down with an alcohol pad.
- 4) Align edges of template B with door panel edges as shown in illustration, and secure with masking tape.

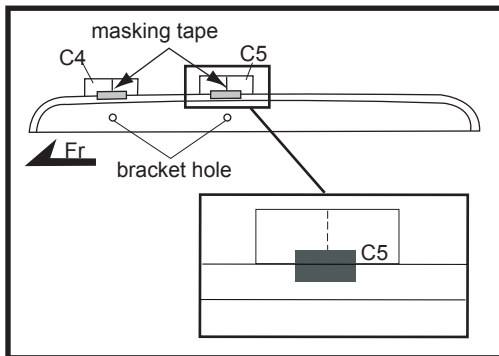

- 5) Align centerline of template C4 and C5 to each of the two bracket holes of the rear deflector and tape them flush to the deflector (see illustration).

INSTALLATION INSTRUCTIONS - SIDE WINDOW DEFLECTOR

7. INSTALLATION PROCEDURE

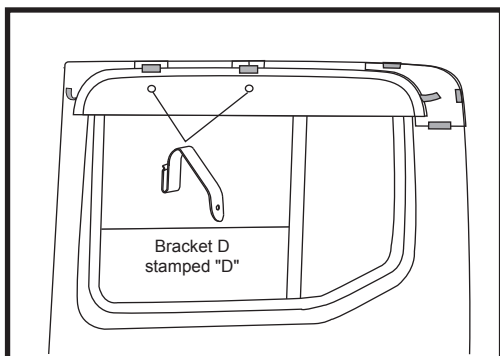
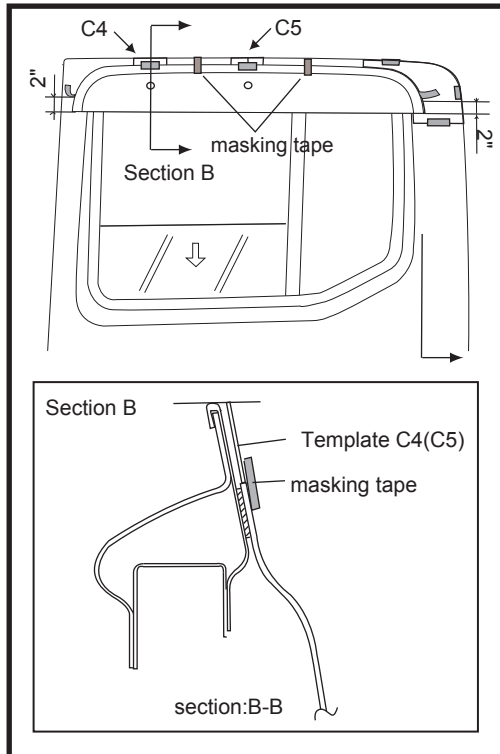

6) The surface temperature where the deflector will be mounted should be at least 60° F or 15° C for proper start-up adhesion of the tape. Use a hot air blower if the temperature is below 60° F.

7) Peel off 2" of tape liner from the front and rear ends of the flange.

8) Align the deflector to template B and position the deflector evenly from the door panel edge using the top edge of templates C4 and C5 as a guide (see Section B).

9) Temporarily fix it to the door with masking tape.

10) Lightly press the exposed areas of tape to secure and verify position.

11) Install two pieces of bracket D onto door flange aligned with the deflector holes.

INSTALLATION INSTRUCTIONS - SIDE WINDOW DEFLECTOR

7. INSTALLATION PROCEDURE

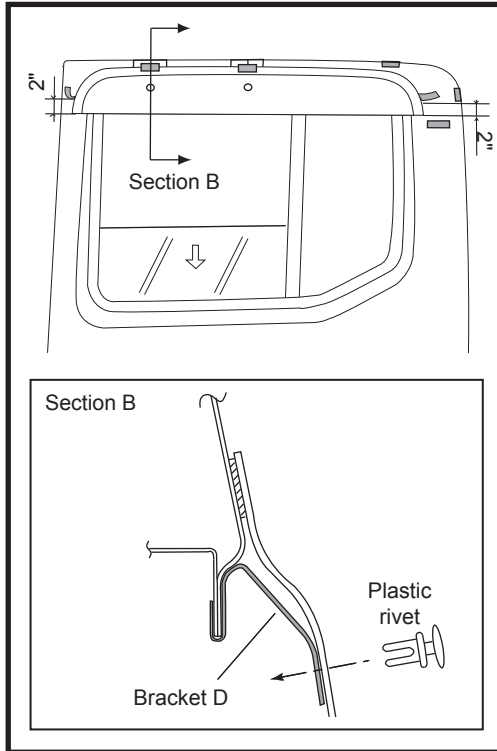

12) Fasten the deflector to bracket D using plastic rivets.

13) Carefully remove all templates.

IMPORTANT
DO NOT TEAR OR DAMAGE THE TEMPLATES. ALL TEMPLATES ARE REUSED FOR PASSENGER SIDE INSTALLATION.

14) Remove and discard the remaining strips of masking tape.

15) Remove the remaining tape liner by pulling on the free end from front to rear.

16) Apply by hand a minimum of 15 lbs. of pressure on the deflector flange along the length of the tape.

17) Reinstall the weather seal to the original position.

18) Operate door window open / close to confirm its operation.

Repeat steps 1 - 18 for passenger side.