



GENUINE PARTS

INSTALLATION INSTRUCTIONS

DESCRIPTION: Rear Underbody Protector
APPLICATION: JUKE (2011)
PART NUMBER: Rear Underbody Protector (H5901 1KA0A)

KIT CONTENTS:

Item	Qty.	Part Description	Service Part Number
A	1	Rear Underbody Protector	---
B	7	M6 Square Head-Bolt	---
C	8	M6 Nut	---
D	8	Rubber Washer	85274-AC015
E	2	J-Nut	---
F	2	Tapping-Screw	---
G	2	Washer	---
H	2	Spacer	---
I	1	Paper-Template	---
J	1	Paper-Template	---
K	1	Paper-Template	---
L	1	Installation Instruction Replacement Template	---



A



B



C



D



E



F



G



H



I

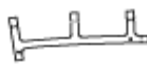

J



K



L

TOOLS REQUIRED:

- Center Punch
- Clip Remover
- Protective Eyewear
- Drill
- Box Driver(10mm)
- Ultrasonic Cutter or Scissors
- Cutter or Knife
- Phillips Head Screwdriver
- Saw
- Masking Tape
- Drill Bit(3mm, 6mm, 8mm, 10mm)
(1/8", 1/4", 5/16", 25/64")

PRE-INSTALLATION NOTES:

- These instructions are for the left side of the vehicle; the same procedure applies to the right side.
- For the right side installation, use the template with the text facing the vehicle.

INSTALLATION PROCEDURE:

Fig. 1

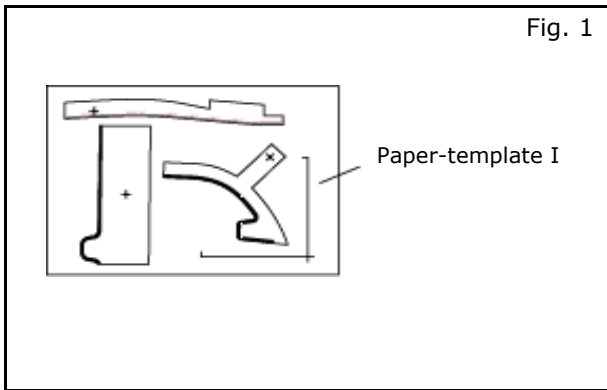

- 1) Cut off the paper-template I.

NOTE;

FOR THE RIGHT SIDE INSTALLATION, USE THE PAPER-TEMPLATE WITH THE TEXT FACING THE VEHICLE.

Fig. 2

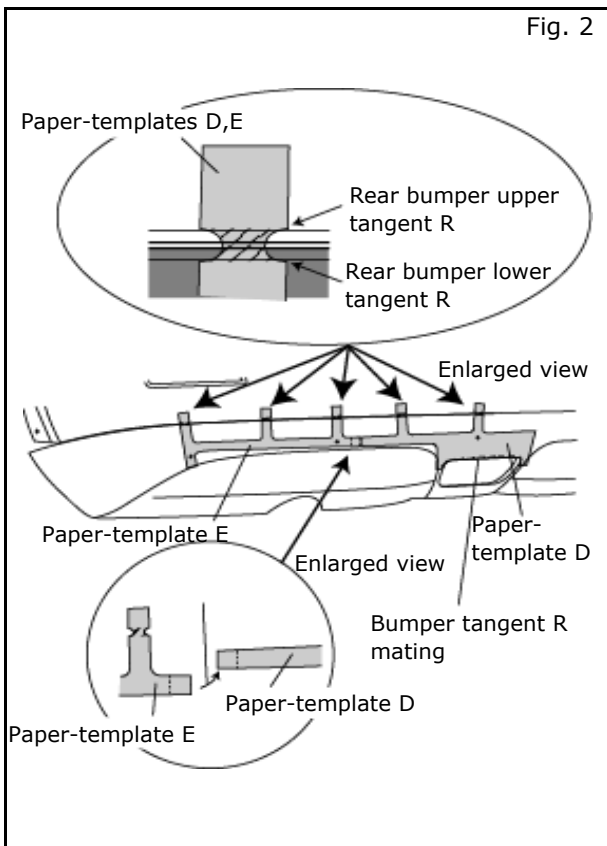

- 2) Apply the paper-template D to the rear bumper with the masking tape, aligning the paper-template D to the bumper tangent R. See Fig. 2.
- 3) Apply the paper-template E to the rear bumper with the masking tape, overlapping it at the joint part of the paper-template D and aligning on the boundary line between the bumper upper and lower on the top. See Fig. 2.
- 4) Make marks by using center punch at the hole positions.

NOTE:

TAKE CARE NOT TO TEAR THE PAPER-TEMPLATES D AND E, WHICH WILL BE REUSED FOR MAKING ON THE RIGHT SIDE.

- 5) Remove the paper-templates D and E slowly.

Fig. 3

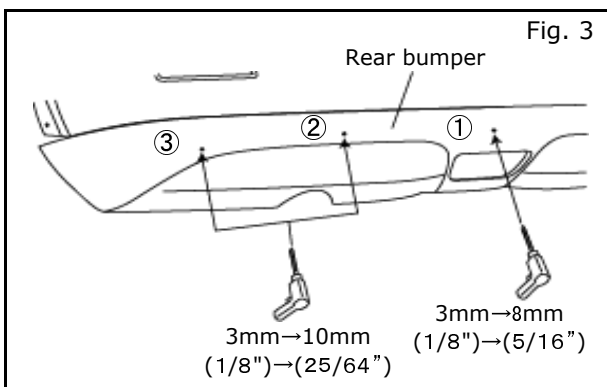

- 6) Make holes at the hole positions marked in the procedure 4) above, by 3mm(1/8") hole then 8mm(5/16") for hole①. See Fig. 3.
- 7) Make holes at the hole positions marked in the procedure 4) above, by 3mm(1/8") hole then 10mm(25/64") for hole② and ③. See Fig. 3.

INSTALLATION PROCEDURE:

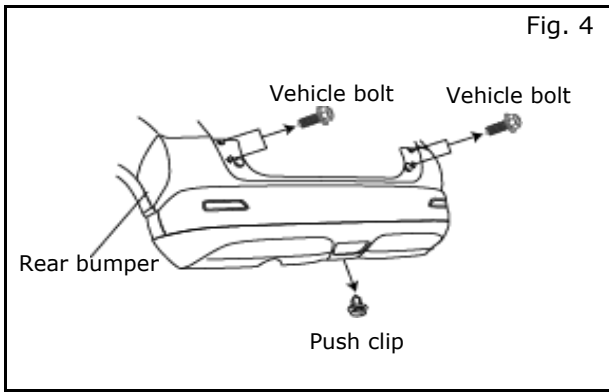

- 8) Open the vehicle back door. Remove the push clip on the lower surface. See Fig. 4.
- 9) Remove the vehicle bolts. See Fig. 4.

NOTE:
TAKE CARE NOT TO LOSE THE REMOVED VEHICLE BOLTS AND PUSH CLIP, WHICH WILL BE REUSED.

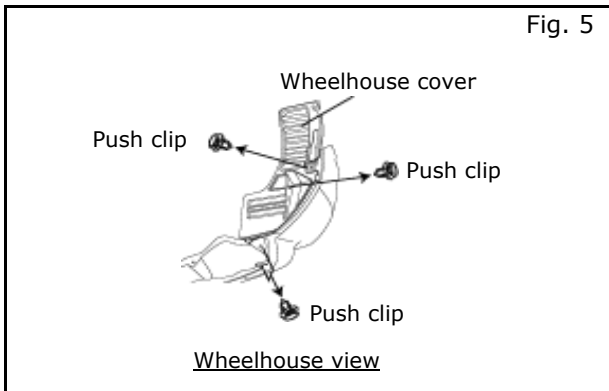

- 10) Remove the push clips, then the wheelhouse covers. See Fig. 5.

NOTE:
TAKE CARE NOT TO LOSE THE REMOVED VEHICLE BOLTS AND PUSH CLIPS, WHICH WILL BE REUSED.

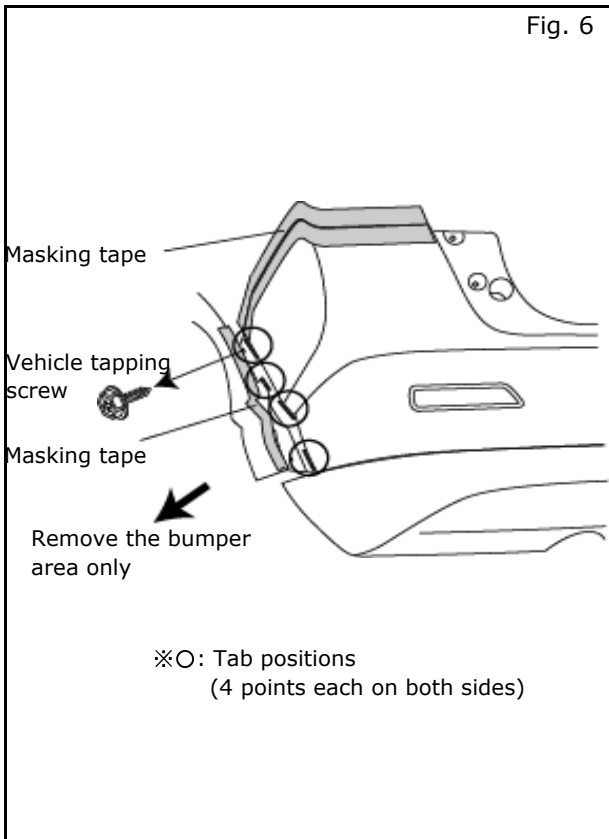

- 11) Remove the vehicle over fender the bumper area only. See Fig. 6.

NOTE:
TAKE CARE NOT TO DAMEGE THE REMOVED TABS, WHICH WILL BE REUSED.

- 12) Apply masking tape to protect the vehicle parts. See Fig. 6.
- 13) Remove the vehicle tapping screw. See Fig. 6.

NOTE:
TAKE CARE NOT TO LOSE THE REMOVED TAPPING SCREW, WHICH WILL BE REUSED.

- 14) Remove the rear bumper.

INSTALLATION PROCEDURE:

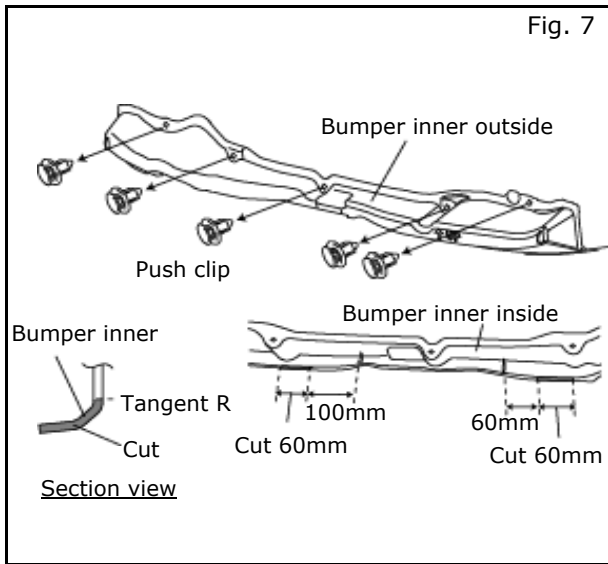

- 15) Remove the push clips fixing the bumper inner, then remove the bumper inner. See Fig. 7.

NOTE:

TAKE CARE NOT TO LOSE THE REMOVED VEHICLE PUSH CLIPS, WHICH WILL BE REUSED.

- 16) Cut off the bumper inner by using the ultrasonic cutter or scissors. See Fig. 7.

CAUTION:

TAKE CARE NOT TO BE INJURED WHILE USING THE ULTRASONIC CUTTER.

- 17) Install the bumper inner with the push clips removed in the procedure 15). See Fig. 7.

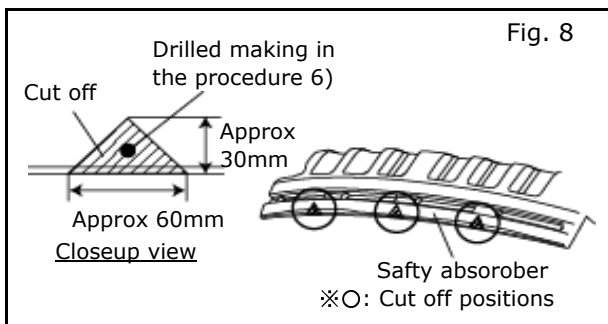

- 18) Remove the safety absorber from the vehicle.

- 19) Cut off the safety absorber by using the saw or knife. See Fig. 8.

CAUTION:

TAKE CARE NOT TO BE INJURED WHILE USING THE SAW.

- 20) Install the safety absorber to the vehicle.

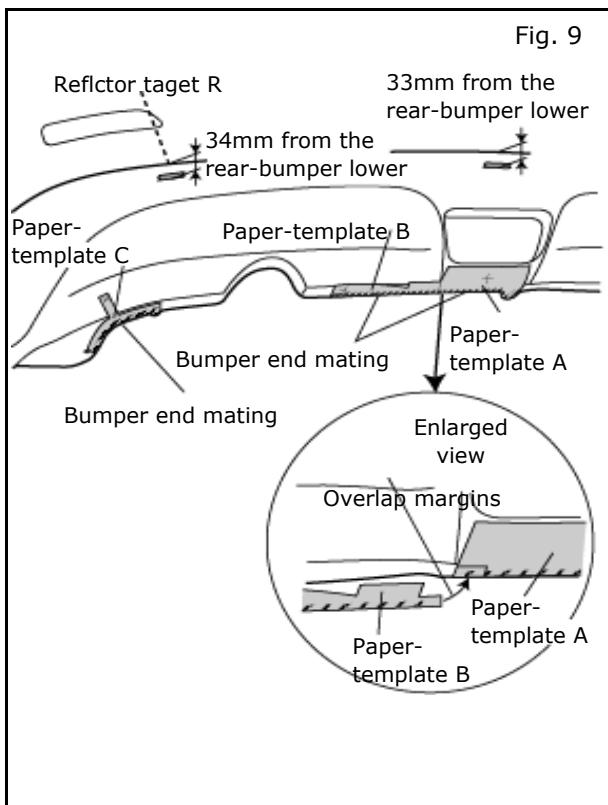

- 21) The paper-template A to the rear bumper with the masking tape aligning it to the end of the lower surface. See Fig. 9.

- 22) Apply the paper-template B to the rear bumper with the masking tape, overlapping it at the joint part of the paper-template A and aligning it on the end of the lower surface. See Fig. 9.

- 23) Apply the paper-template C to the rear bumper with the masking tape, aligning it to the end of the lower surface and the vehicle hole. See Fig. 9.

- 24) Make marks by using center punch at the hole positions. See Fig. 9.

NOTE:

TAKE CARE NOT TO TEAR THE PAPER-TEMPLATES A AND B, WHICH WILL BE REUSED FOR MAKING ON THE RIGHT SIDE.

- 25) Remove the paper-templates A, B, C slowly.

- 26) Make marks at the center of the rear bumper and at the bottom part of the reflector with the masking tape. See Fig. 9.

INSTALLATION PROCEDURE:

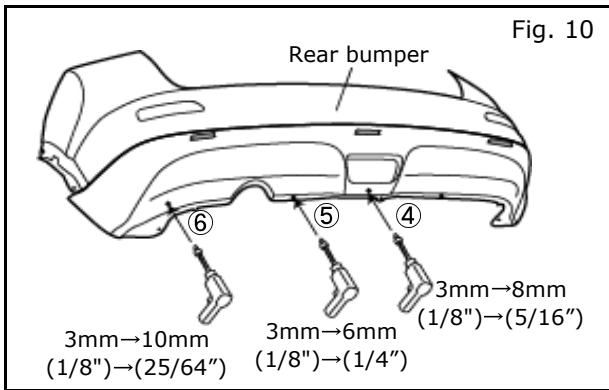

- 27) Make holes at the hole positions marked in the procedure 24) above, by 3mm(1/8") hole then 8mm(5/16") for hole ④. See Fig. 10.
- 28) Make holes at the hole positions marked in the procedure 24) above, by 3mm(1/8") hole then 6mm(1/4") for hole ⑤. See Fig. 10.
- 29) Make holes at the hole positions marked in the procedure 24) above, by 3mm(1/8") hole then 10mm(25/64") for hole ⑥. See Fig. 10.

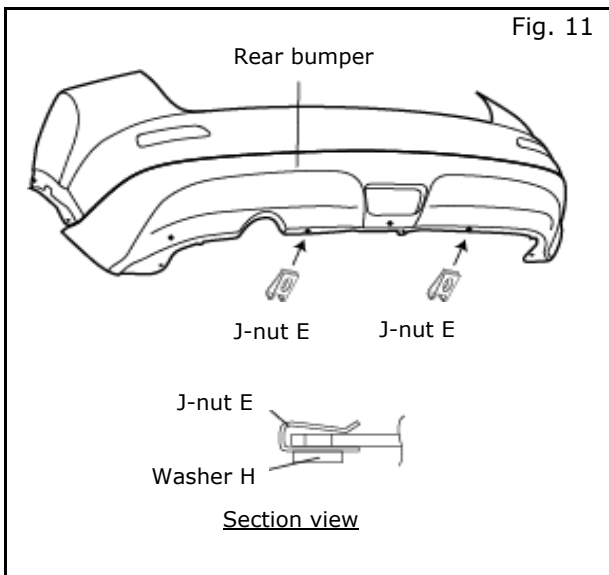

- 30) Insert the J-nut E to the lower surface of the rear bumper. See Fig. 11.
- 31) Install the washer H to the J-nut E. See Fig. 11.

NOTE:
TAKE CARE NOT TO MIX UP INSTALLING DIRECTION OF THE J-NUT E.

INSTALL THE WASHER H TO THE J-NUT E ALIGNING THE CENTERS OF THE BOTH HOLES.

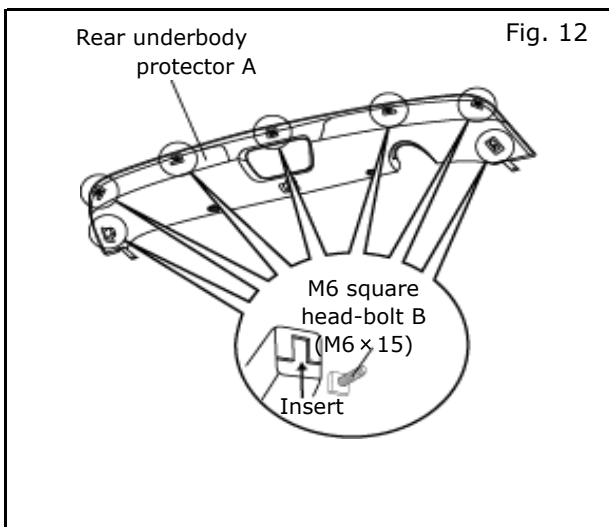

- 32) Insert the M6 square head-bolt B to the rear underbody Protector A. See Fig. 12.

INSTALLATION PROCEDURE:

Fig. 13

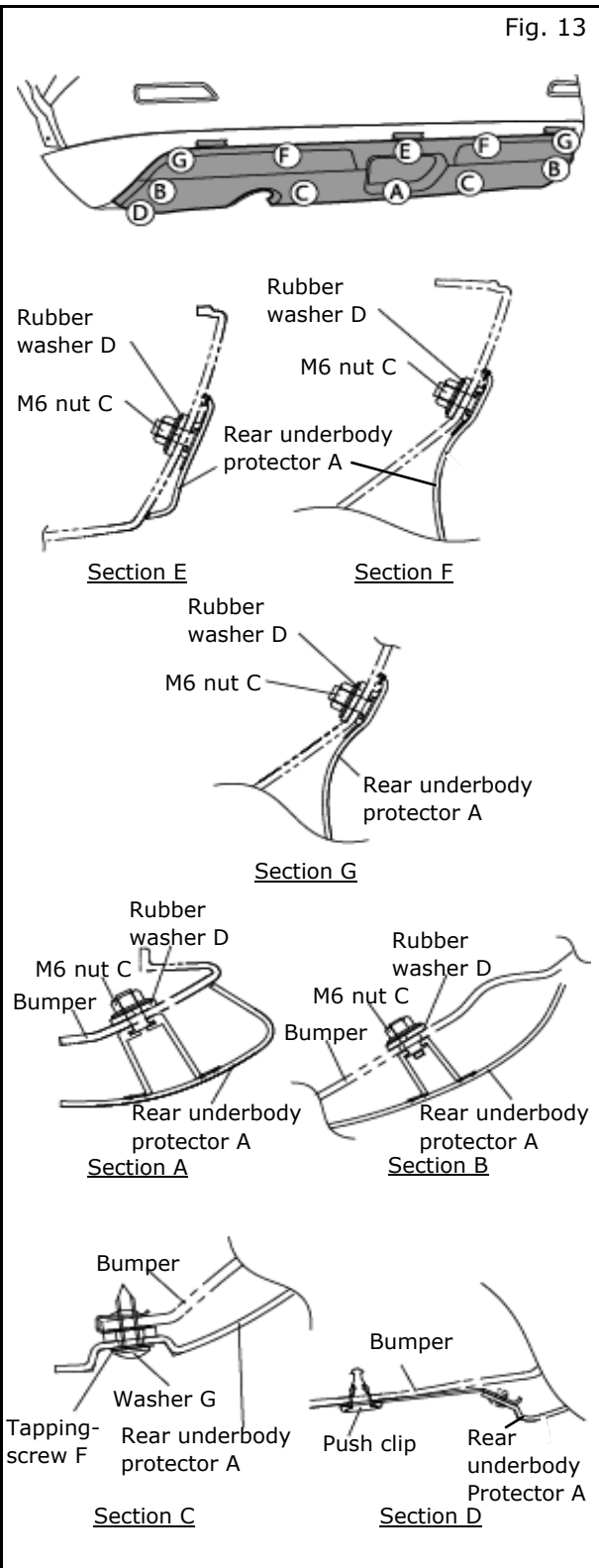

- 33) Install the rear underbody protector A to the rear bumper aligning to the marking.
- 34) Fix points E to G in order with the rubber washer D and M6 nut C. See the Section E to Section G in Fig. 13.
- 35) Fix the rear bumper assembly at the center of the bumper rear side with the rubber washer D and M6 nut C. See the section Section A in Fig. 13.
- 36) Fix the rear bumper assembly with the rubber washer D and M6 nut C. See the section Section B in Fig. 13.
- 37) Temporarily fix the rear bumper assembly with the tapping-screw F and the washer G. See the Section C in Fig. 13.
- 38) Fix the rear bumper assembly with the push clip. See the Section D in Fig. 13.

NOTE:
CHECK FOR VEHICLE GAP BEFORE INSTALLING REAR BUMPER ASSEMBLY ON VEHICLE.

INSTALLATION PROCEDURE:

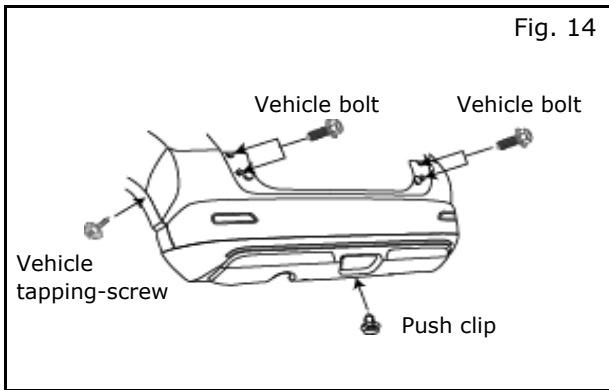

- 39) Install the push clip on the lower surface removed in the procedures 8) , 9) and 13) , with the vehicle tapping screw and the vehicle bolts. See Fig. 14.

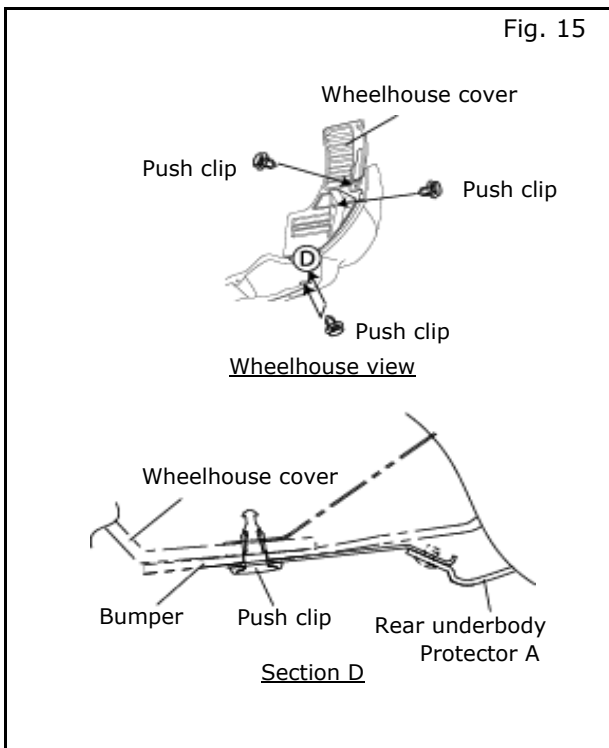

- 40) Install the wheelhouse cover with the push clips removed in the procedure 10). See the Section D in Fig. 15.

- 41) Remove masking tape and install the vehicle over fender removed in the procedure 11). See Fig. 15.

ACCESSORY CHECK:

- Check all **Critical Installation Steps**.

RE-INSTALLATION OF REMOVED PARTS:

- Re-install all removed vehicle parts. Refer to the vehicle service manual for more details.

FINAL INSPECTION:

- Verify re-installed trim parts for proper flush fit (no gap, no waviness, etc.).
- Verify all clips are fully engaged and locked.
- Verify re-installed trim parts are free from cracks, scratches or stress marks.
- Verify interior and exterior is not damaged.
- Place the Owner Manual, Quick Reference Guide, and/or other Manual in the glove box.