



# GENUINE PARTS

## INSTALLATION INSTRUCTIONS

<b>DESCRIPTION:</b>	Hood Bug Deflector
<b>APPLICATION:</b>	Pathfinder
<b>PART NUMBER:</b>	999D5 X2200

**KIT CONTENTS:**

Item	Qty.	Part Description	Service Part Number
A	1	Hood Protector	---
B	2	Center Clip	---
C	2	Outer Clip	---
D	2	Outer Wing Clip	---
E	6	Small Screw	---
F	6	Fibre Washer	---
G	6	Abrasive Tape	---
H	4	Neoprene Washer (Rectangle)	---
I	4	Large Screw	---
J	4	Plastic Washer	---
K	1	Screw Plug	---
L	1	Alcohol Wipe (2-pk)	---

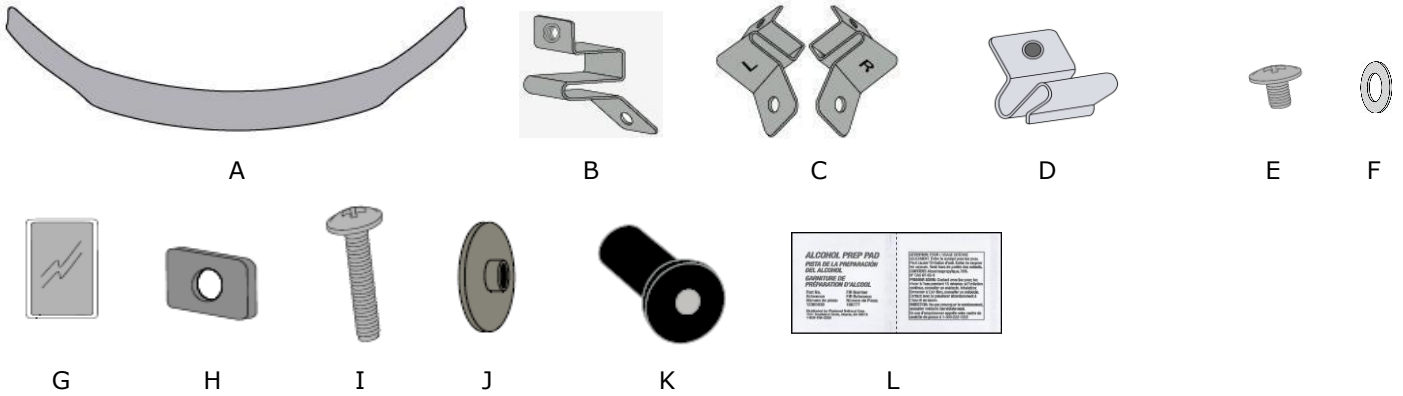

**TOOLS REQUIRED:**

- Drill
- Clean Cloth
- 5/16" (8mm) Drill Bit
- Non-Permanent Marker / Pencil
- Masking Tape
- Soapy Water
- #2 Phillips Screwdriver
- Clip Removal Tool / Flathead Screwdriver

**INSTALLATION CAUTIONS / NOTES:**

- Before installation clean hood surface with mild soap and water using a soft cloth or chamois.
- Never use ammonia based cleaners or solvents on the hood protector
- Dealer Installation Recommended.
- Allow tape to cure for 4 hours before driving vehicle.

## INSTALLATION PROCEDURE:

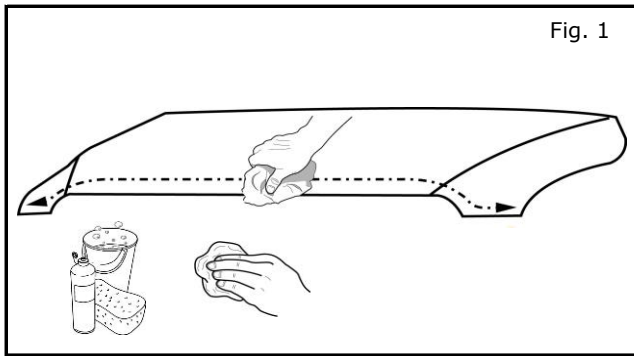

- 1) Clean hood installation area using soapy water and clean cloth.

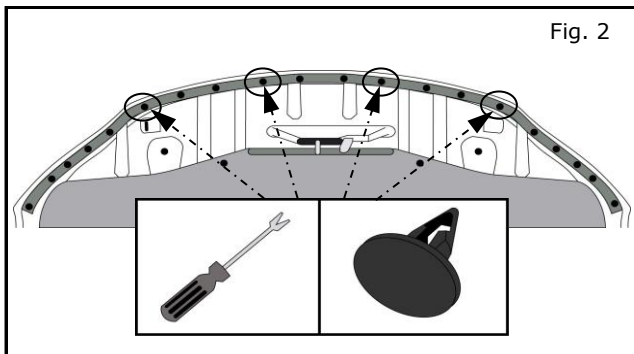

- 2) Open hood.
- 3) Cover engine compartment with protective blanket to catch any dropped hardware.
- 4) Remove 4 grommets using clip removal tool or flathead screwdriver.

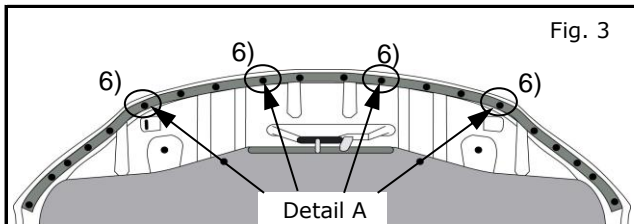

- 5) Attach masking tape to drill bit 6mm from end.
- 6) Enlarge existing holes using 5/16" (8mm) drill bit at 4 locations shown.

**Note: Make sure drill is on low speed and do not use excessive force.**

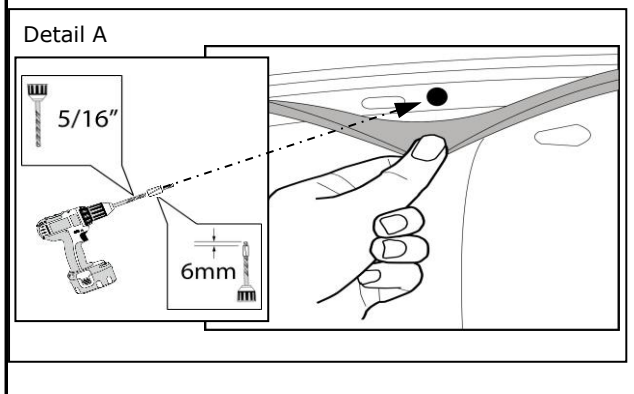

- 7) Remove any metal shavings and burrs from drilled holes.

## INSTALLATION PROCEDURE:

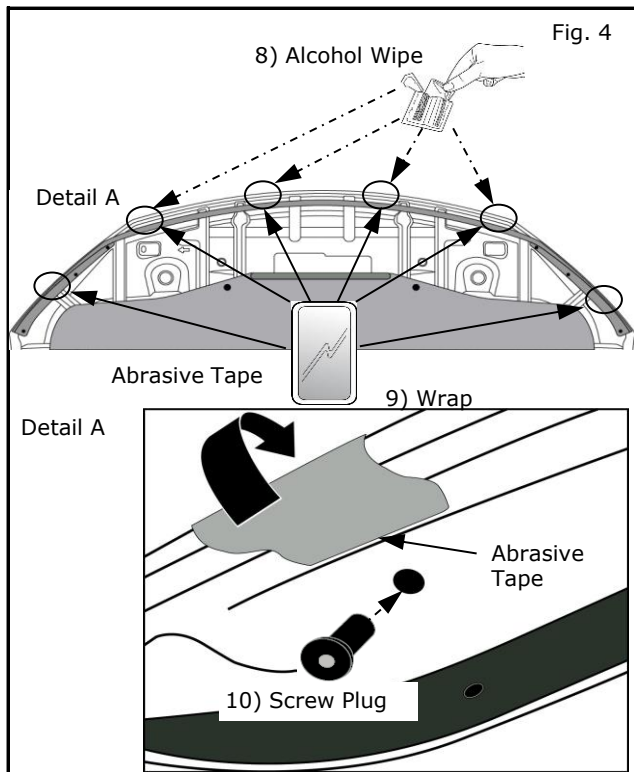

- 8) Clean top and underside of hood areas adjacent to holes with alcohol wipes.
- 9) Wrap abrasive tape over hood lip.  
**Note: To protect vehicle paint from clip, apply tape so that half of tape is on the topside and half is on the underside of hood.**
- 10) Insert screw plugs into 4 previously drilled out holes.

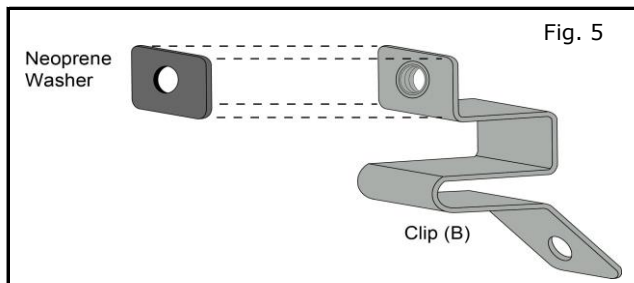

- 11) Peel backing off neoprene washers.
- 12) Fix neoprene washers to clips (B, C and D).  
**Note: As shown in Fig. 5 (clip B).**

## INSTALLATION PROCEDURE:

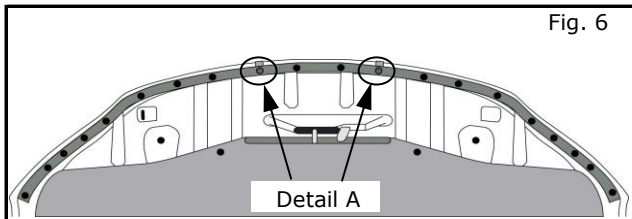

- 13) Slide center clips (B) onto hood under rubber trim and secure using the large screw through large washer, rubber trim and brackets into previously installed screw plug.

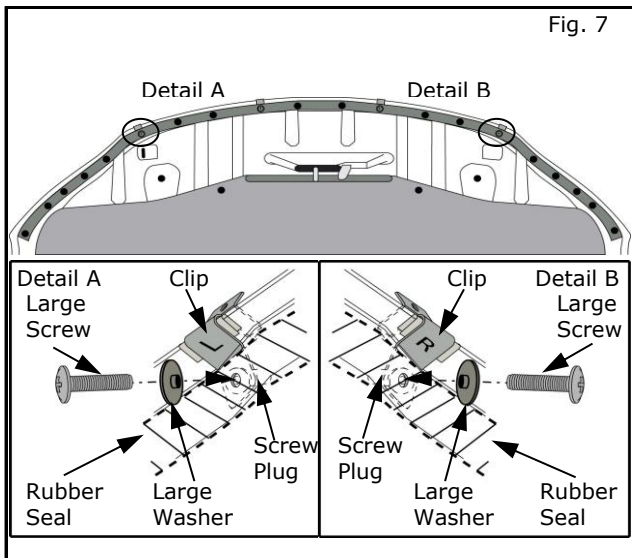
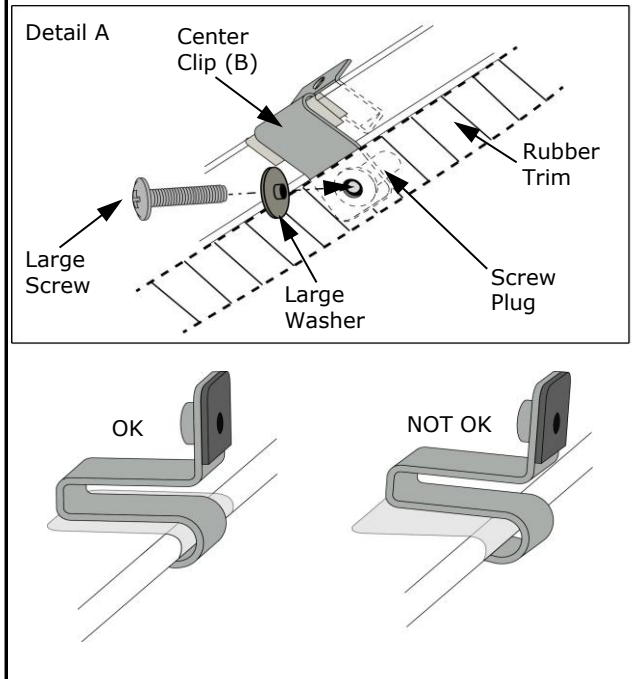

- 14) Secure left and right clips (C) onto hood under rubber trim and secure using large screw through large washer, rubber trim and brackets into previously installed screw plug.

**Note: Right and Left clips are identified (R, L). Center clips (B) have no markings.**

- 15) Remove protective blanket and close hood.

## INSTALLATION PROCEDURE:

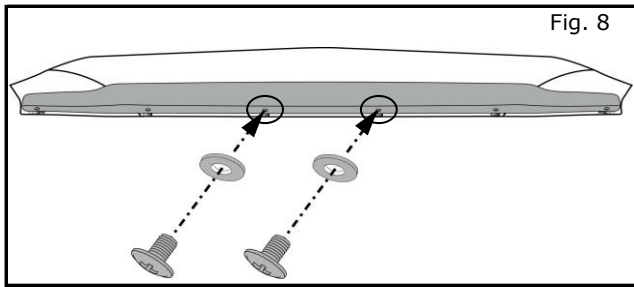

- 16) Insert small screws through fibre washer, loosely secure hood protector to center clips "B".

**Note: Do not fully tighten screws.**

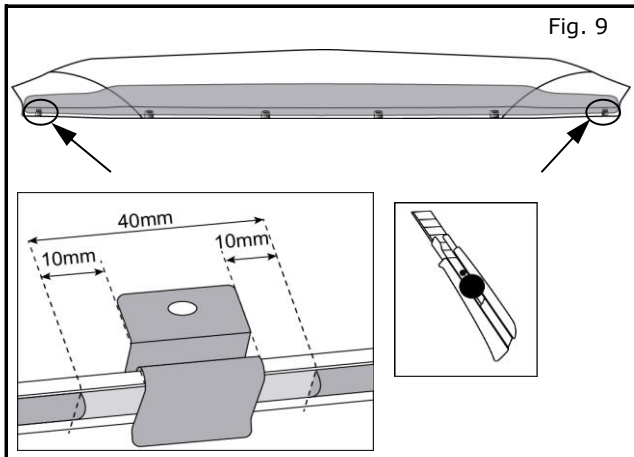

- 17) Trim hood paint seal bead.

- Pull rubber Hood seal down to prevent cutting.
- Using sharp utility knife, cut thin layer (1~2 mm) of hood paint seal on underside of hood near end holes at metal clip locations.
- Cut 10mm either side of the locations.

**Note: Do not cut all the way down to the sheet metal.**

- 18) Clean top and underside of hood areas adjacent to end holes with alcohol wipe.

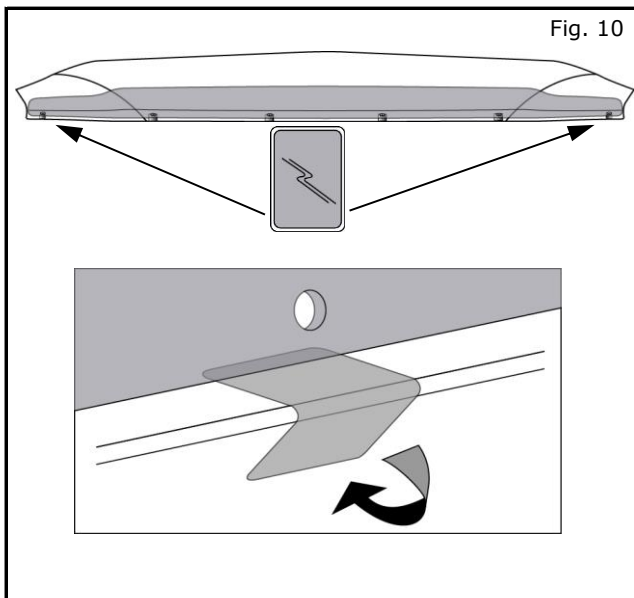

- 19) Wrap abrasive tape over hood lip.

**Note: To protect vehicle paint from clip, apply tape so that half of tape is on the topside and half is on the underside of hood.**

## INSTALLATION PROCEDURE:

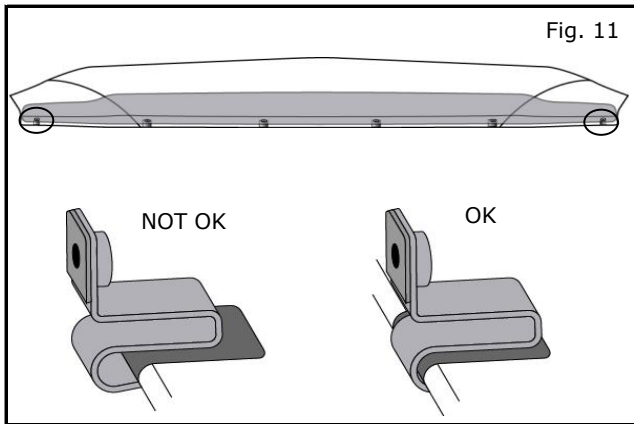

- 20) Install the wing clips "D" over the abrasive resistant tape strips at the previously marked locations.

**Note: Make sure clips are fully seated with no gap to hood edge.**

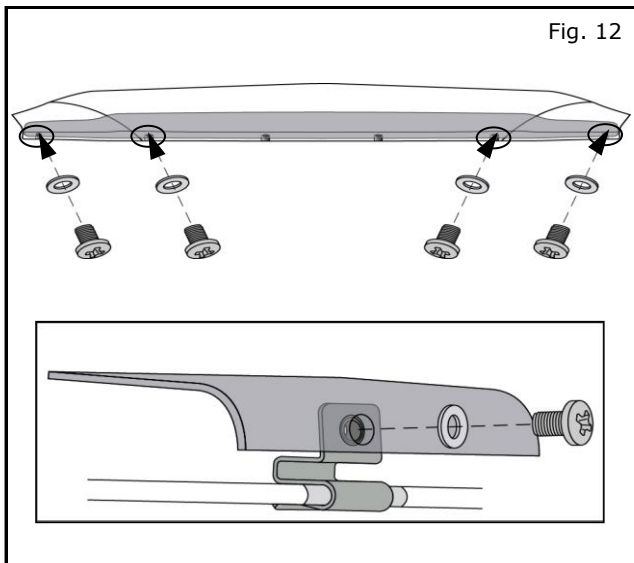

**Note: Do not fully tighten screws.**

- 22) Check to see that the hood protector is centrally located, adjust as necessary.

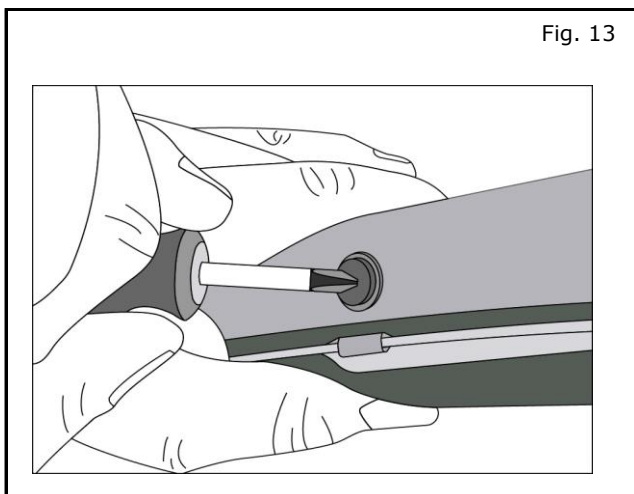

- 24) Remove protective blanket and close hood.