



GENUINE PARTS

INSTALLATION INSTRUCTIONS

1. **DESCRIPTION:** Hood Molding Accent
2. **APPLICATION:** Cube
3. **PART NUMBER:** F5830-1FCxx (xx Designates color)
4. **KIT CONTENTS:**

Item	Qty.	Description	Part Number
A	1	Hood Molding Accent	---
B	2	Clip	76882-6P000
C	2	Grommet	76848-35F00
D	1	Paper Template	---
E	1	Installation Instructions	---

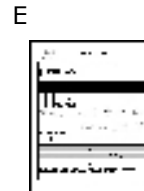
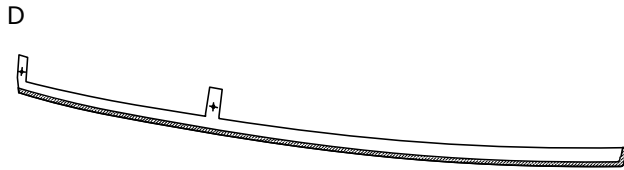
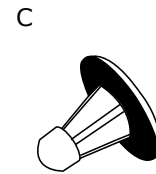
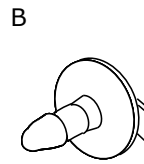

5. TOOLS REQUIRED:

- Center punch
- Drill
- Masking tape
- Phillips screwdriver
- 3 mm (1/8") and 8 mm (5/16") Drill bit
- Deburring tool
- Clean, lint-free wiping cloth
- 100% Alcohol
- Rust preventative(P/N 999MP-9G001P)

6. PRE-INSTALLATION CAUTIONS/NOTES:

CAUTION

- Install the Hood Molding Accent when the ambient temperature is above 60°F (15°C).
- Do not wash or expose the vehicle to a wet environment for 24 hours after installing the Hood Molding Accent.

INSTALLATION INSTRUCTIONS - Hood Molding Accent

7. INSTALLATION PROCEDURE:

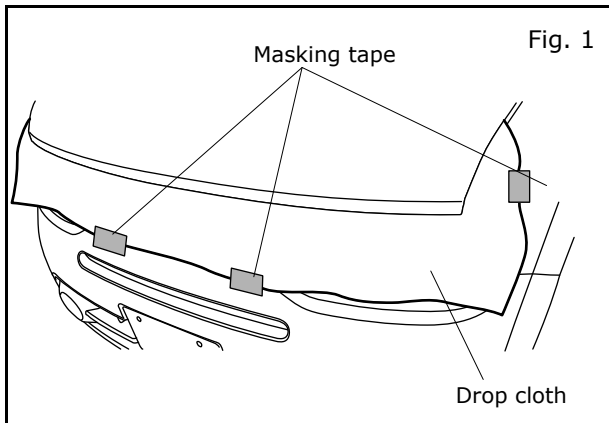

1. Installation preparation
 - a) Open vehicle engine hood.
 - b) Place drop cloth over engine area. See Fig. 1.

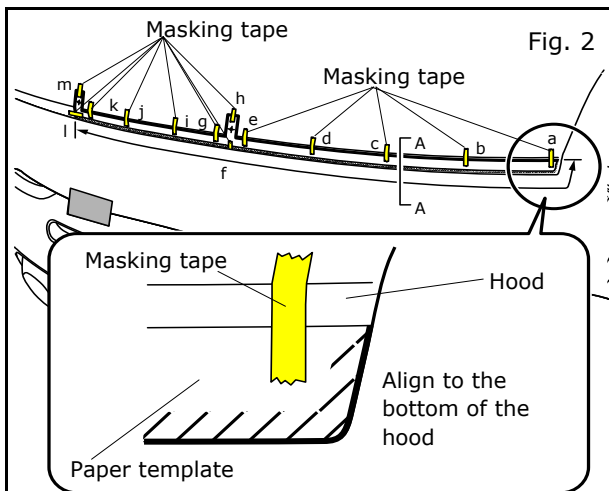

- c) Starting from the driver's side, align the paper template to the hood and apply masking tape in the required locations to hold template in place. See Fig. 2.
- d) Mark the hole position (+) with center punch. See Fig. 2-1.
- e) Remove masking tape and template.

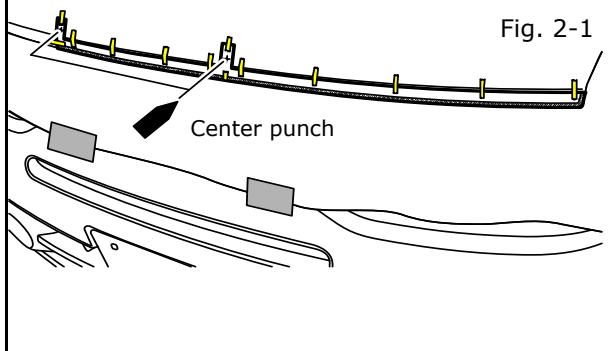
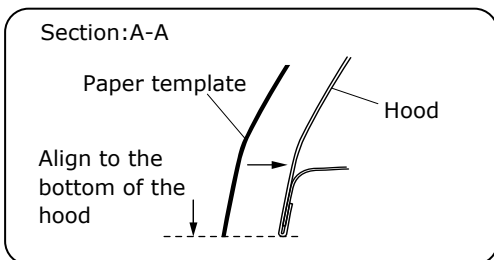

INSTALLATION INSTRUCTIONS - Hood Molding Accent

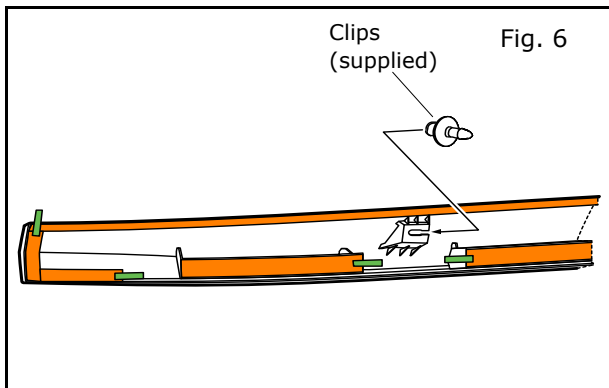
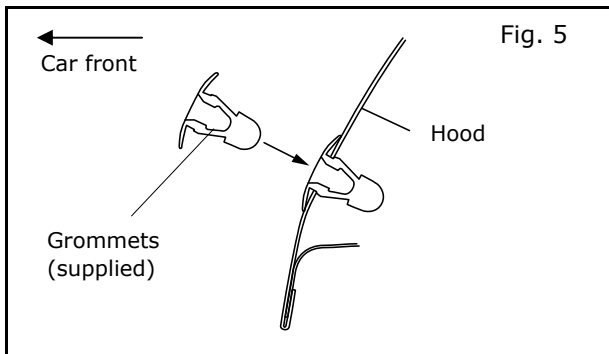
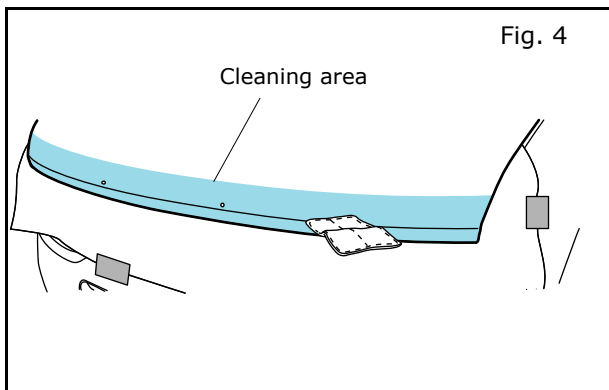
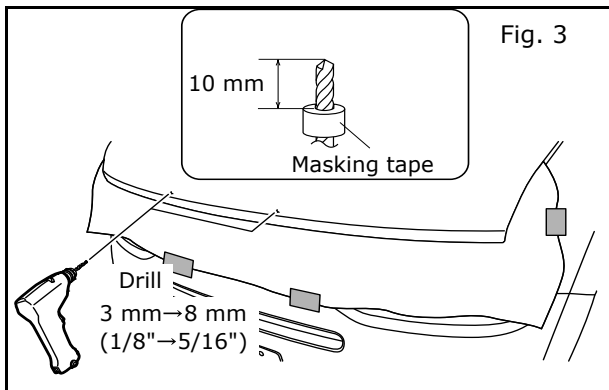

- f) Wrap masking tape around 3 mm (1/8") and 8 mm (5/16") drill bits, approximately 10 mm from the tip.
- g) Drill 3 mm (1/8") and 8 mm (5/16") holes at the 2 marked locations on the hood. See Fig. 3.
- h) De-burr all drilled holes and remove metal shavings from inside the hood using compressed air:
- i) Using a clean, lint free cloth and 100% alcohol, wipe any dirt and oil from the mounting surface. Let area dry thoroughly. See Fig. 4.
- j) Apply rust preventative (P/N 999MP-9G001P) to all drilled holes. Let area dry thoroughly.

⚠ CAUTION

- Failure to apply rust preventative will result in red rust.

- k) Install the grommets(supplied) in the drilled holes. See Fig. 5.

⚠ CAUTION

- "Click" sound indicates that the grommets are completely assembled to the hood molding accent.

2. Hood molding accent installation

- a) Assemble the clips(supplied) to the hood molding accent. (2 locations) See Fig. 6.

⚠ CAUTION

- "Click" sound indicates that the clips and bolts are completely assembled to the hood molding accent.

INSTALLATION INSTRUCTIONS - Hood Molding Accent

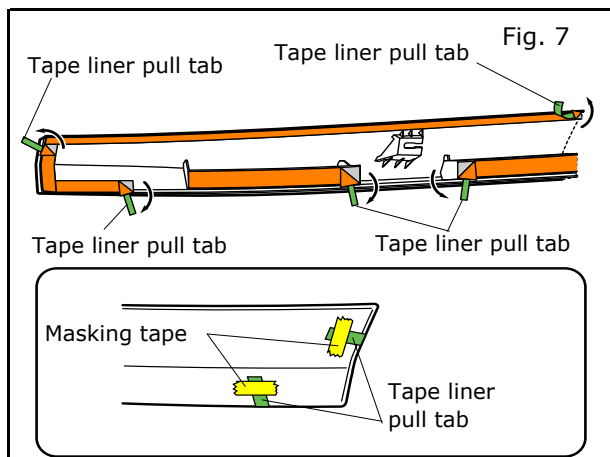

- b) Fold tape liner pull tabs onto the hood molding accent painted surface and apply masking tape to ensure that the pull tabs are accessible. See Fig. 7.

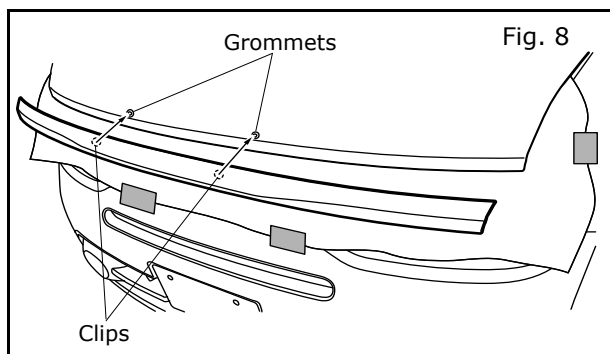

- c) Align the hood molding accent clips to the grommets in the hood. See Fig. 8.
- d) Push down on the hood molding accent to engage the hood molding accent clips in the grommets.

⚠ CAUTION

- Apply pressure until "click" sound is heard. "Click" sound indicates that the clips are fully engaged in the grommets.

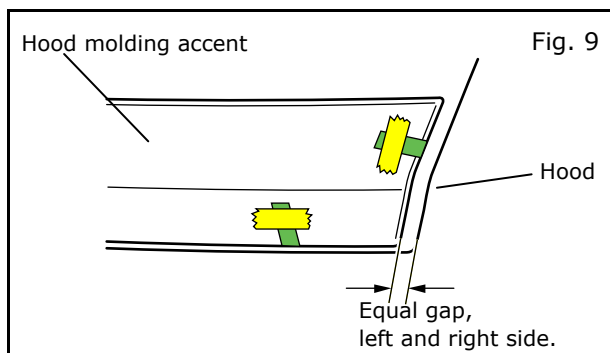

- e) Visually center the hood molding accent on the hood. See Fig. 9.

INSTALLATION INSTRUCTIONS - Hood Molding Accent

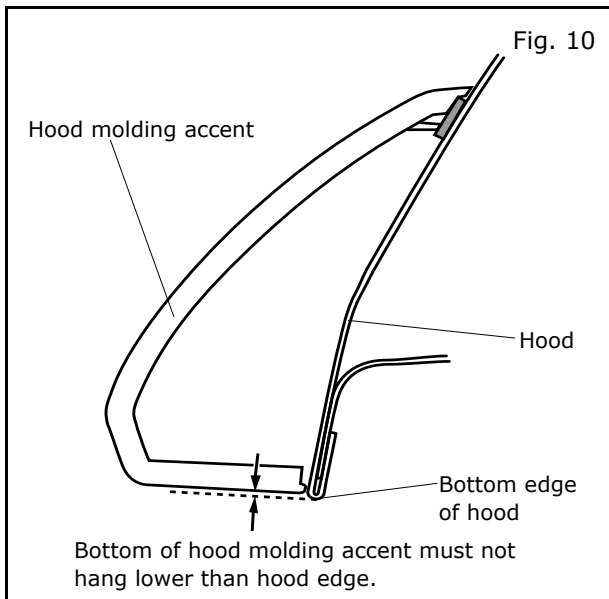

- f) From the side of the vehicle, align the end of the hood molding accent to match the contour of the hood. See Fig. 10.

⚠ CAUTION

- Be sure the bottom of the hood molding accent does not hang lower than the edge of the hood. Failure to do so may result in the hood molding accent interfering with the vehicle grille. See Fig. 10.

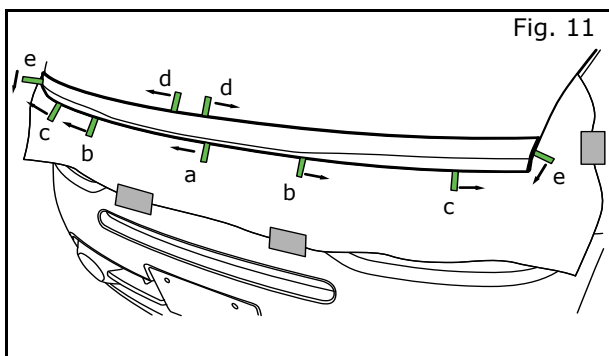

- g) Starting at the center and moving outward, remove the double-sided tape liner a through c and apply at least 15lbs. of pressure to the hood molding accent to ensure that the hood molding accent is attached. See Fig. 11.

⚠ CAUTION

- Be sure the bottom of the hood molding accent does not hang lower than the edge of the hood. Failure to do so may result in the hood molding accent interfering with the vehicle grille. See Fig. 10.

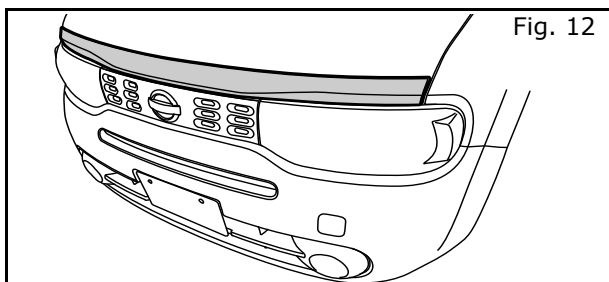

- h) Starting at the center and moving outward, remove the double-sided tape liner d through e and apply at least 15lbs. of pressure to the hood molding accent to ensure that the hood molding accent is attached. See Fig. 11.
- i) Apply at least 15lbs. of pressure to the hood molding accent to ensure that the hood molding accent is attached. See Fig. 11.

- j) Remove drop cloth and close hood. See Fig. 12.