



GENUINE PARTS

INSTALLATION INSTRUCTIONS

| | |
|---------------------|--------------------------------------|
| DESCRIPTION: | Vehicle Tracking and Recovery System |
| APPLICATION: | Sentra (2007) |
| PART NUMBER: | 999Q8 VW001 |

KIT CONTENTS:

| Item | Qty. | Part Description | Service Part Number |
|------|------|---|---------------------|
| A | 1 | GPS Control Module | 999Q8 VW000S1 |
| B | 1 | Wire Harness | 999Q8 VW000S3 |
| C | 1 | I/I Download Instructions | 999V2 AW000 |
| D | 1 | Owners Manual | |
| E | 1 | Activation Card (included in owners manual) | |
| F | 8 | 6" Cable Ties | |
| G | 2 | 12" Cable Ties | |
| H | 1 | Foam Pad (on module) | |
| I | 20 | Foam Tape | |
| J | 2 | Posi-Taps | 999M1 VT000 |
| K | 1 | Mirror Hanger (Nissan VTRS information) | |
| L | 1 | Alcohol wipe | |

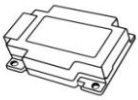

A



B

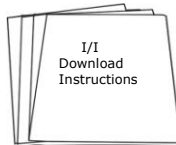

C



D

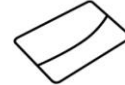

E



F

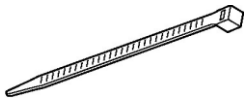

G

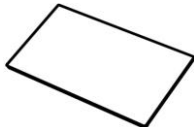

H

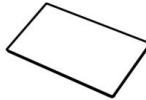

I



J



K



L

TOOLS REQUIRED:

- Ratchet
- 10mm socket
- #2 Phillips screwdriver
- T15 (optional)
- Plastic pry bar
- Masking Tape
- Wire cutter

PRE-INSTALLATION WARNINGS, CAUTIONS, CRITICAL STEPS, and NOTES:

- Dealer Installation Recommended. Instructions may refer to service manual.
- This part is to be installed at a surface temperature of 65-100°F.
- Posi-Tap instructions must be followed exactly as described in this instruction

INSTALLATION OVERVIEW:

System Block Diagram

Fig.1



Vehicle outline with installation overview

Fig.2

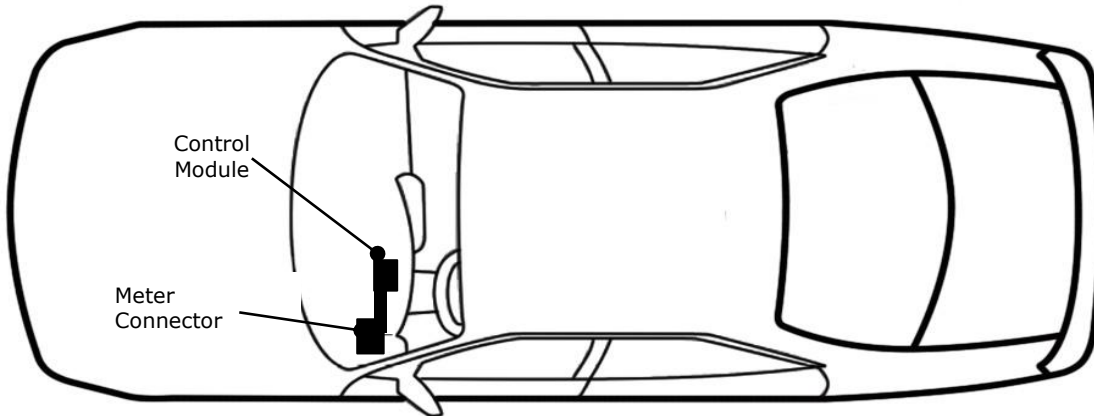

INSTALLATION PROCEDURE:

- 1) Apply parking brake
- 2) Confirm the vehicle is no longer in the default shipping state (Extended Storage Switch Pulled Up and BCM in Transit Mode). Failure to confirm the vehicle has been removed from this state will result in the loss of normal vehicle operation. The confirmation requires two checks:
 - 2a) Locate the Extended Storage Switch in the cabin fuse block. Once located, check that it is in the "Customer" position. See below for reference.
 - 2b) Turn the ignition switch from "OFF" to "ON" position. If turn indicators illuminate for approx. 1 minute, the vehicle is in shipping mode. To exit shipping mode, return the ignition switch to "OFF" position. Simultaneously push the wiper and turn signal stalks downward and hold for 2 seconds.

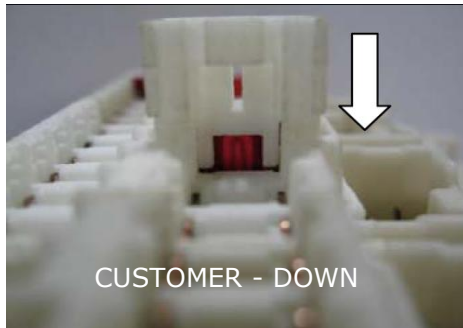
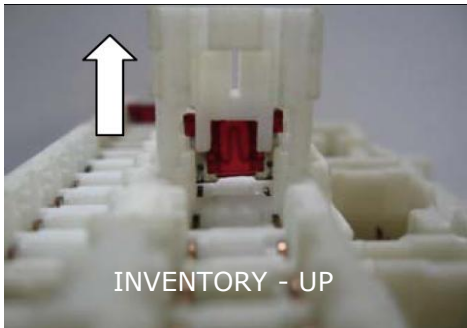
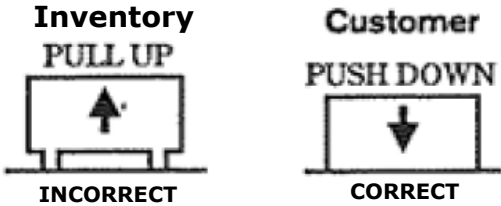

Note: Typical vehicle condition shown above. Switch is easily identifiable by the permanent, push-pull fuse holder. Actual position on the fuse block may vary, vehicle to vehicle.

- 3) Turn ignition switch to "ON" position
- 4) Record the customer radio presets and other presets as required

| Preset | 1 | 2 | 3 | 4 | 5 | 6 | 7 | |
|--------|---|---|---|---|---|---|---|--|
| | | | | | | | | |
| | | | | | | | | |
| | | | | | | | | |

- 5) Put the shift lever in "P" position
- 6) Turn the ignition switch to "OFF" position

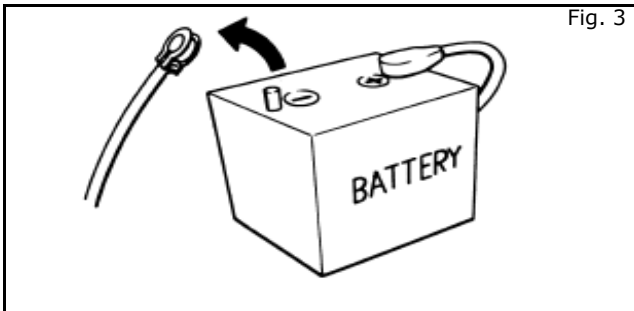

- 7) Disconnect the negative battery terminal

INSTALLATION PROCEDURE:

CAUTION

- Take care not to scratch or damage any component during the removal or re-installation process.
- Trim pieces found to have witness marks or broken clips are not to be reinstalled.

8) Remove the following vehicle parts in the sequence shown below. Store these re-usable parts in a safe and protected manner.

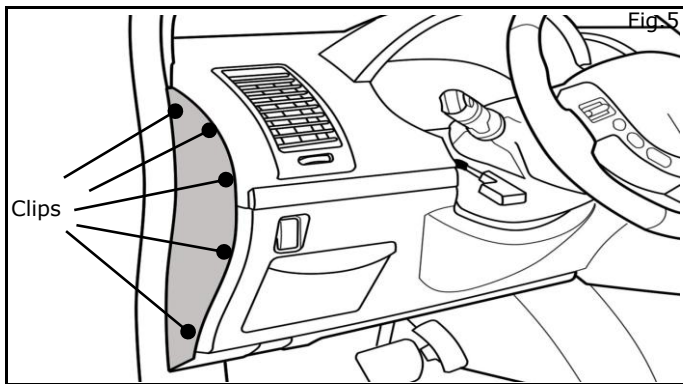
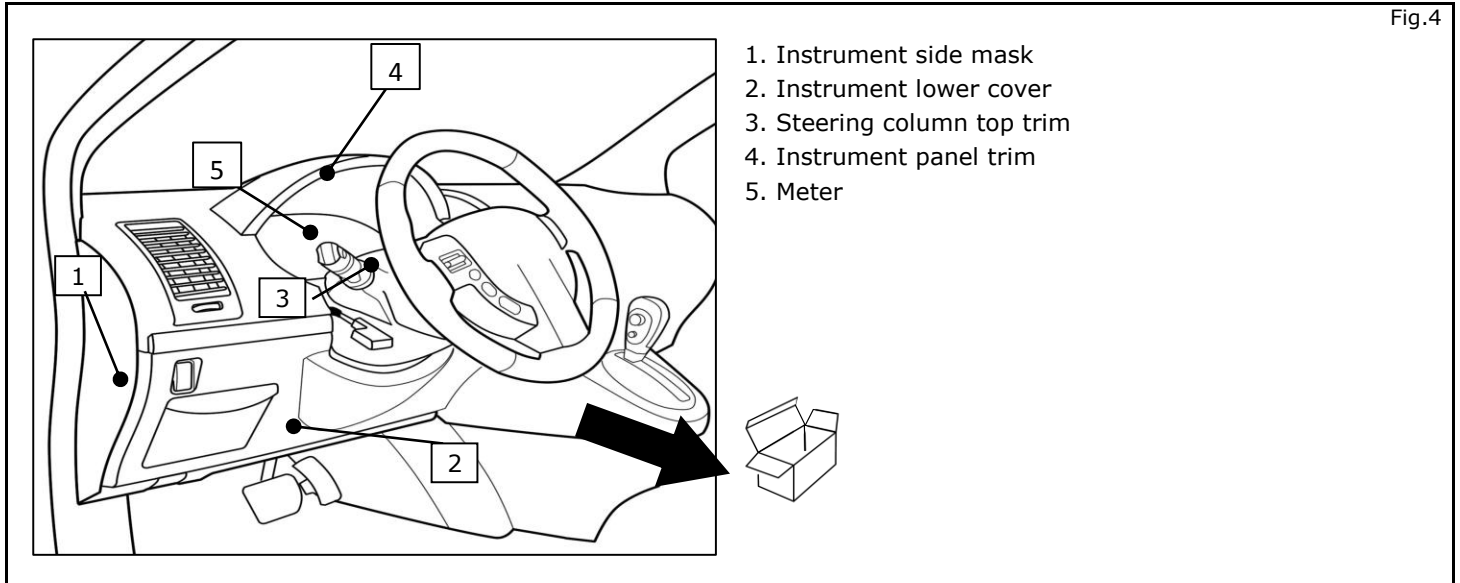

9) Remove the instrument side mask

10) Remove the instrument lower cover

- a) Remove (1) phillips screw or T15 on hood latch release
- b) Remove instrument lower cover, remove harness connectors and aspirator tube

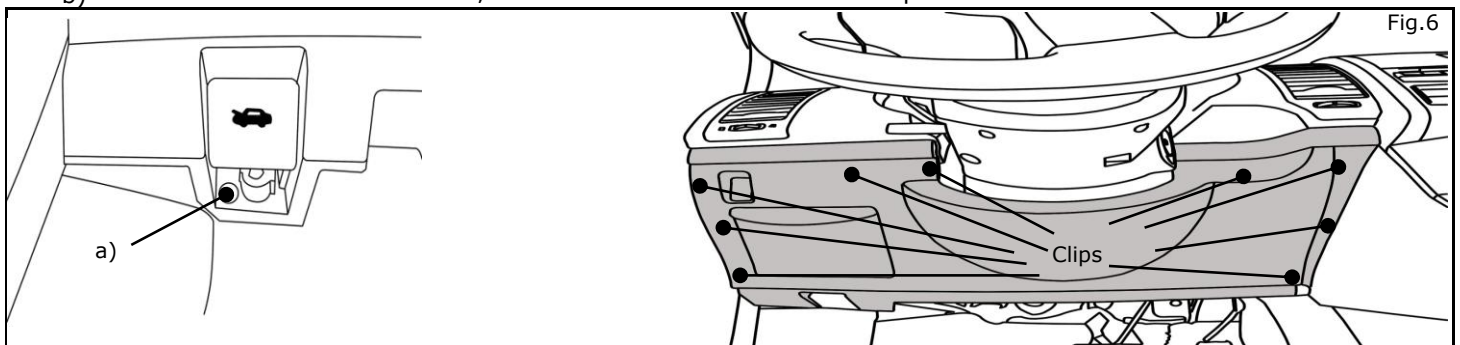

INSTALLATION PROCEDURE:

- 11) Remove steering column cover
 - a) Attach masking tape to steering column trim

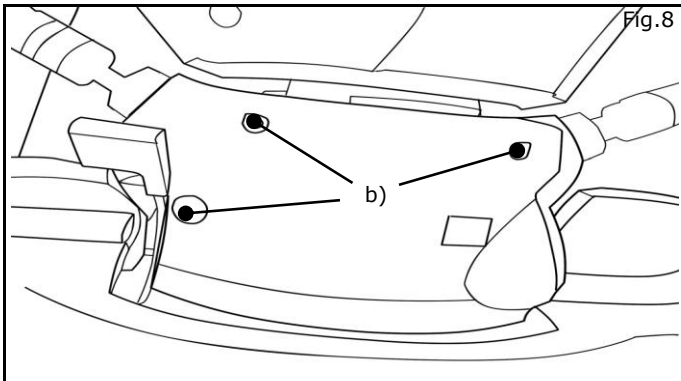
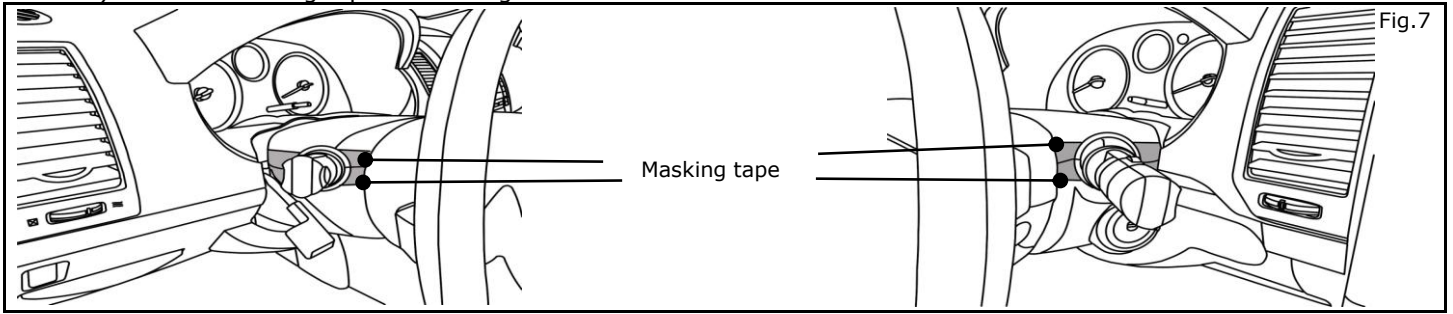

- b) Remove (3) phillips screws from bottom trim
- c) Remove steering column cover top trim

- 12) Remove instrument panel trim

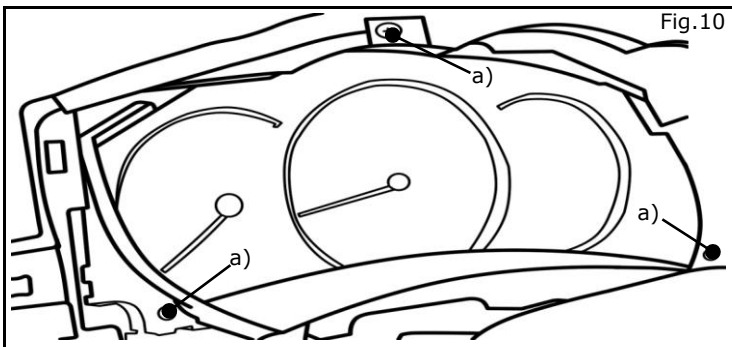
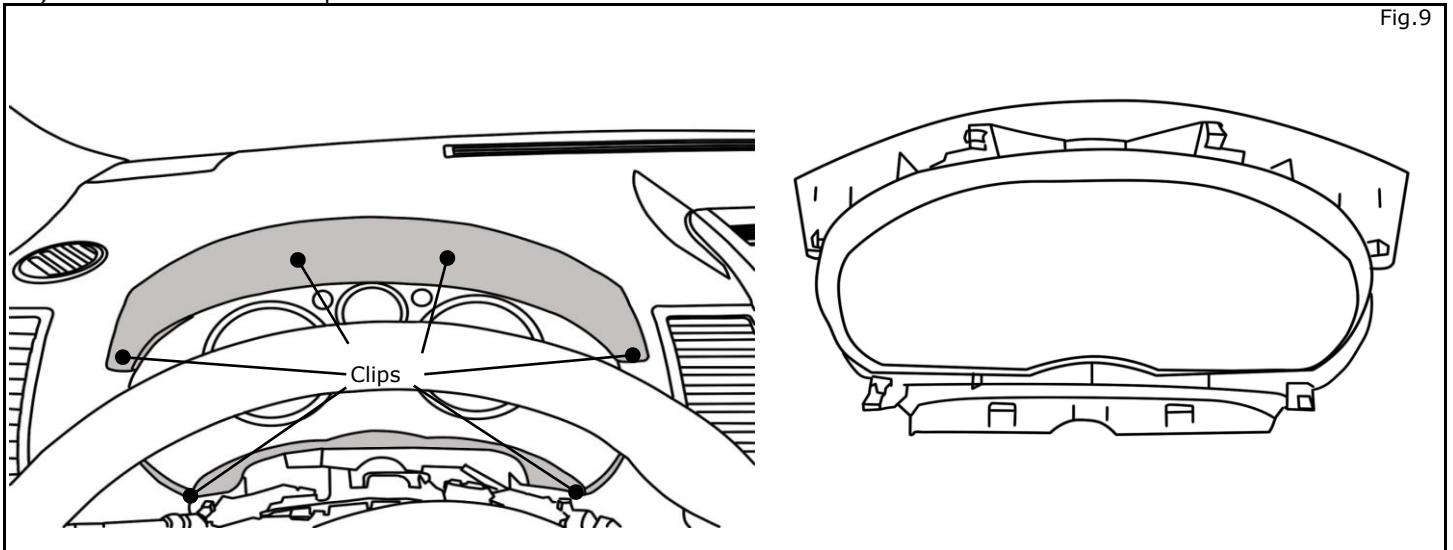

- 13) Remove combination meter
 - a) Remove (3) phillips screws
 - b) Remove combination meter and disconnect

INSTALLATION PROCEDURE:

CAUTION

- Color(s) given in illustration(s) are for reference only. Use location(s) where color deviates.
- If a vehicle wire is being used by another accessory and a posi-Tap is present, tap the accessory wire not the vehicle wire
- Do not pinch the harness between trim when re-installing the Instrument Panel

- 14) Connect the posi-tap
- Peel off tape on factory harness prior to installing posi-tap.
 - Tap the Vehicle Tracking and Recovery System Red wire to the vehicle Yellow B+ wire.

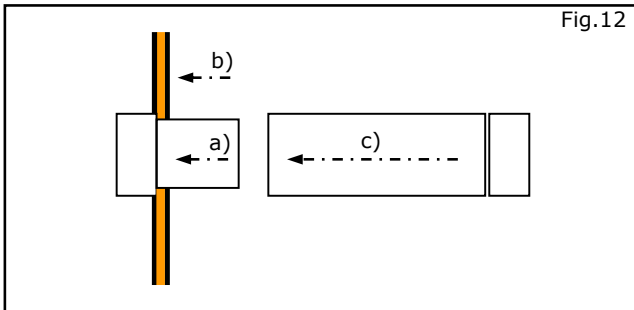
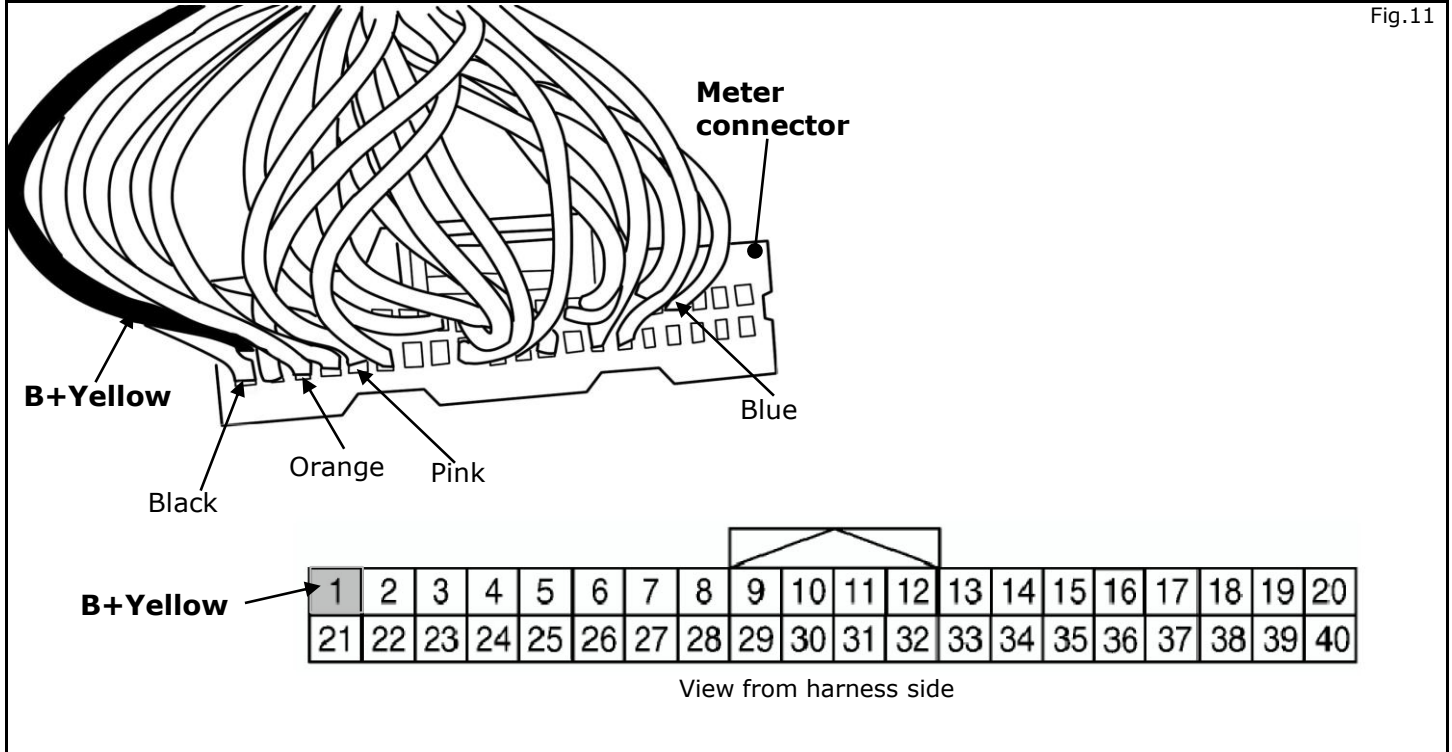

- 15) Tap vehicle wire.
- Remove cap (slot side) from the tap body
 - Slide cap around vehicle wire.
 - Tighten the tap **TIGHT** with finger pressure.

NOTE:
Do not re-use the tap for subsequent re-installation. Figures are not to scale.

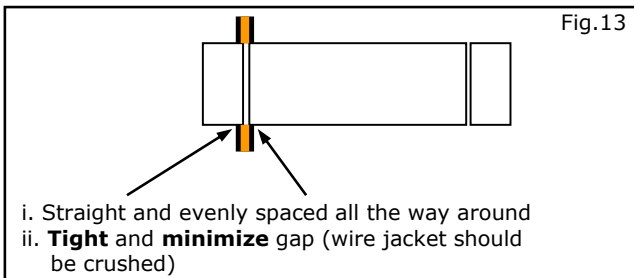

- 16) Inspect the tap to ensure correct installation.

NOTE:
Avoid putting pressure on the vehicle wire and tap for the remainder of the installation.

INSTALLATION PROCEDURE:

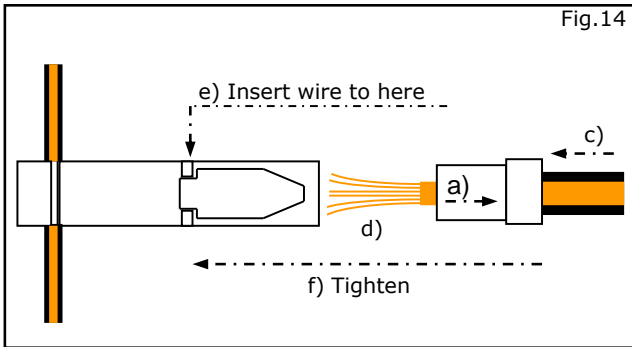

- 17) Tap accessory wire.
 - a) Remove tap (non-pierce) side from tap.
 - b) Remove the protective stub from the wire.
 - c) Insert wire through the non-pierce side opening.
 - d) Spread the individual strands into fan shape.
 - e) Insert wire into the tap body and ensure that it is all the way in.
 - f) Tighten the tap **TIGHT** with finger pressure.

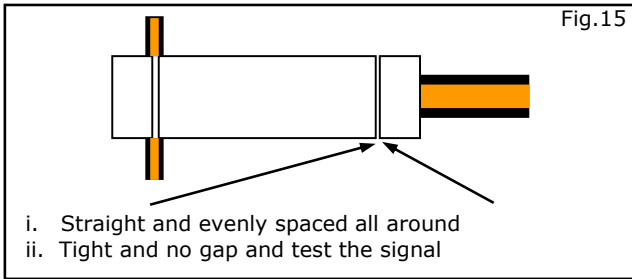

- 18) Confirm the tapped accessory wire.
 - a) Inspect the tap to ensure correct installation.
 - b) Test the signal to ensure that it is working properly.

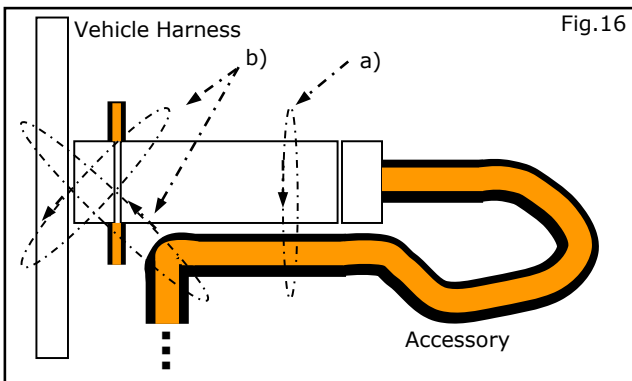

- 19) Secure the tap.
 - a) Secure the tapped wire on the non-pierce side to the body of the tap with electrical tape (≥ 2 revolutions).
 - b) Secure the body to harness where vehicle wire is being tapped with electrical tape (≥ 2 revolutions).

20) Tap the Vehicle Tracking and Recovery System Brown wire to the vehicle Brown ACC wire.
See steps 15-19 for wire tap installation instructions.

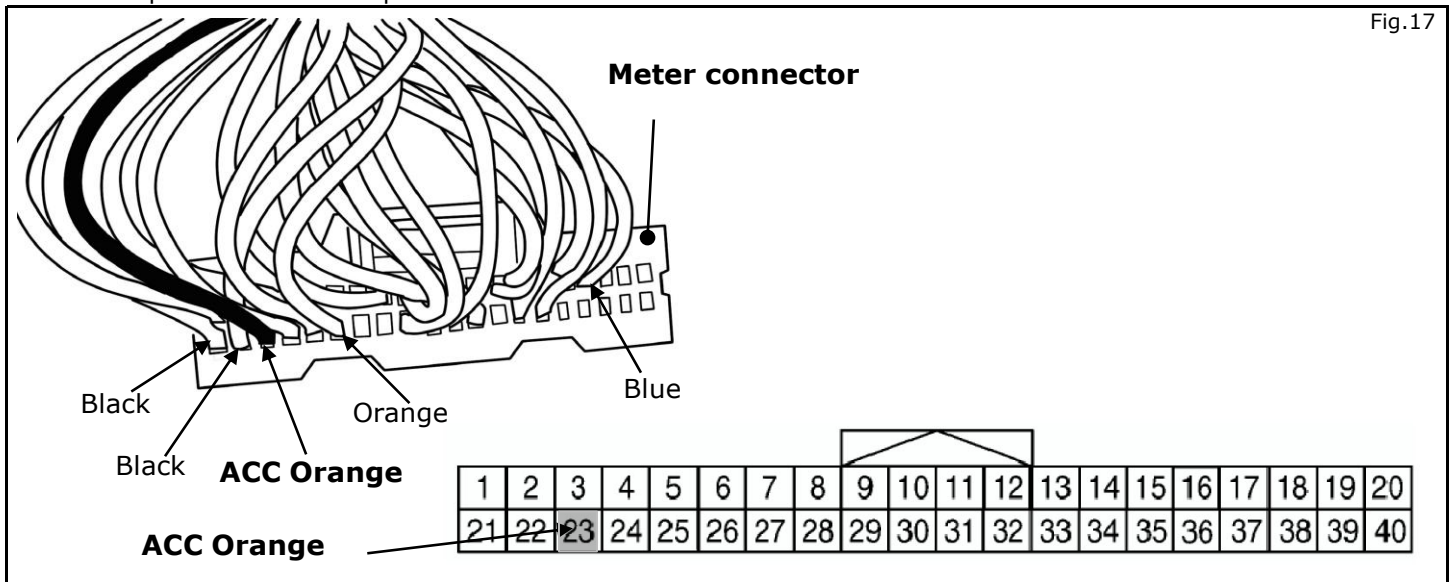

INSTALLATION PROCEDURE:

CAUTION

- When stacking multiple ground eyelets, **DO NOT** stack the stems of the eyelet
- When stacking multiple ground eyelets, leave a 30° spacing between the stems of the eyelet

- 21) Connect ground to BCM bracket
- a) Route ground wire to dash frame
 - b) Attach cable ties

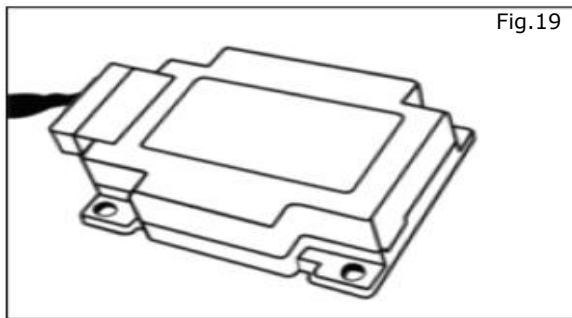
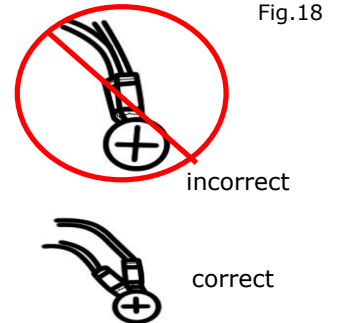
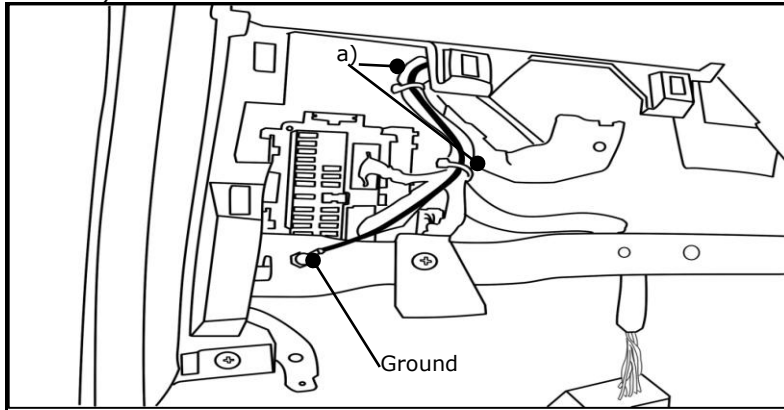

- 22) Connect the harness to the control module

ACCESSORY CHECK:

- Connect all vehicle harness connections (without re-assemble)
- Connect the battery negative terminal and tighten the nut to appropriate torque.
- Check all **Critical Installation Steps**.
- Verify all wiring is secure and not exposed.
- Trim all excess cable ties flush.
- Verify the Control Module Diagnostic L.E.D.'s are blinking Green
- Verify proper Diagnostic L.E.D. blinking pattern (without engine start)
 - Turn ignition switch to "OFF" position, the Green L.E.D. will blink brightly once every three seconds
 - Turn ignition switch to "ON" position for ten seconds, the Green L.E.D. will continue to blink brightly once every three seconds

ACCESSORY CHECK:

Turn ignition switch to "OFF" position, the Green L.E.D. will be dim and blink once every three seconds

Disconnect the negative battery terminal

INSTALLATION PROCEDURE:

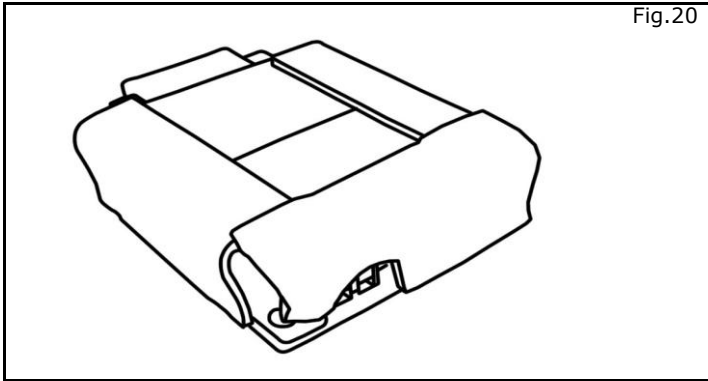

- 23) Prepare the module
a) Attach foam tape to control module top and sides

- b) Clean installation surface with $\geq 90\%$ alcohol/water solution
c) Peel tape liner from foam pad on Module
d) Adhere module to top of HVAC duct

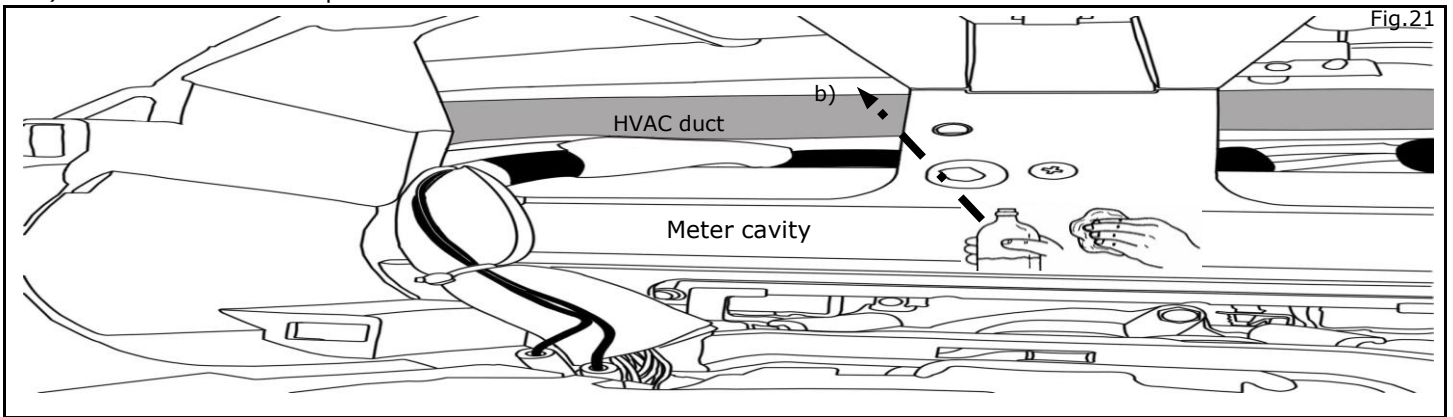

- 24) Secure the harness
a) Secure harness with cable tie with 140mm service loop from GPS Tracking Connector
b) Attach cable ties
c) Attach foam tape

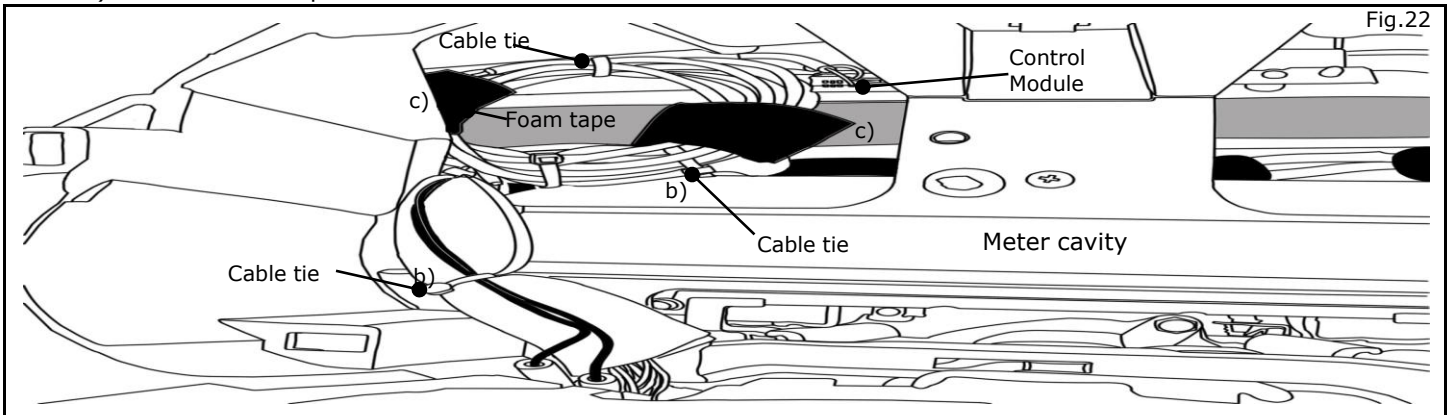

FINAL INSPECTION:

25) Re-install all removed vehicle parts. Refer to the vehicle service manual for more details.



CAUTION

Use caution when re-installing interior components to avoid damage, scratches, or breaking of mounting clips. Refer to the vehicle service manual for more information.

- Verify re-installed trim parts for proper flush fit (no gap, no waviness, etc.).
- Verify all clips are fully engaged and locked.
- Verify re-installed trim parts are free from cracks, scratches or stress marks.
- Verify vehicle headliner, seat, steering wheel, center console, floor carpets, etc. are not soiled.
- Verify interior and exterior is not damaged.
- Connect the battery negative terminal and tighten the nut to 5.4 N-m (47.8 lb-in)
- Turn ignition switch to "ON" and confirm proper operation of Vehicle Systems
 - If equipped, verify all window and sunroof one touch operation and perform the reset procedure if necessary. Refer to the vehicle service manual for more details.
 - Confirm proper audio function (AM, FM, SAT, CD and AUX).
- Re-program radio presets and other vehicle settings to the recorded settings.
- Start engine and verify that there are no new Diagnostic Trouble Codes and the Meter is functional.
- Attach additional Label (ESN number) in Owners Manual Page # 1
- Place the Owner Manual, Quick Reference Guide, and/or other Manual in the glove box.
- For activation information, please refer to Owner's Manual
- Secure mirror hanger to rear view mirror

Posi-Tap™ is protected by patent # 5,228,875 5,695,369 5,868,589 6,692,313 Jap 2881414 Aus 708700 Tia 103534
Can 2204826 Mex 200626 Korea 477279 China Z197105562.9 & others pending.