



GENUINE PARTS

INSTALLATION INSTRUCTIONS

DESCRIPTION:	WiFi
APPLICATION:	Altima
PART NUMBER:	T99Q8 4RA0A (Wifi kit) 999Q9-AY000 (Accessory Service Connector) - Not Included in T99Q8 4RA0A WiFi Kit.

KIT CONTENTS:

Item	Qty.	Part Description	Service Part Number
A	1	WiFi TCU Module	T98Q8 4RA0A
B	1	Wire Harness	T98Q8 4RA1A
C	1	Activation Card	
D	8	10" Cable Ties	
E	8	Foam Tape 1" x 3.5"	
F	3	Posi-Taps	999M1 VT000
G	2	Alcohol Wipe	
H	1	Two Sided Foam Tape	
I	5	PET Clear Tape 1" x 4"	
J	1	II Replacement Template	
K	1	Glove Box Brochure	
ITEMS NOT IN KIT THAT MAY BE REQUIRED			
AA	1	Accessory Service Connector (NOT INCLUDED IN KIT)	999Q9 AY000

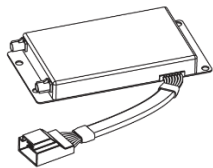

A



B



C



D

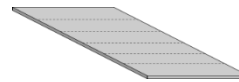

E



K

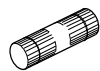

F



G

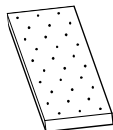

H

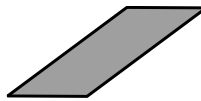

I

J

Important: Read Before Installation

WARNING
The word "WARNING" indicates a potentially hazardous situation that, if not avoided, could result in injury or death. Read the instructions carefully before using the product. The instructions provide the necessary safety information to help you avoid these situations. Read the instructions carefully before using the product. The instructions provide the necessary safety information to help you avoid these situations. Read the instructions carefully before using the product. The instructions provide the necessary safety information to help you avoid these situations.

ABOUT THESE SERVICES
What are these services?
Pay and manage your services from your mobile device.
INTRODUCING NISSAN WiFi AND APPS
POWERED BY AT&T MOBILE ALICE

ACTIVATION SERVICES
How to sign up for services?
Visit www.nissanusa.com or call 1-800-NISSAN-USA for more information. Please read and understand all terms and conditions of use.

TOOLS REQUIRED:

- Wire Cutter
- Nylon Trim Tool
- #2 Phillips Screwdriver
- Flashlight
- Tape Measure
- 10mm Socket
- Ratchet

Vehicle Preparation:

⚠ CAUTION

• **Always confirm the ignition is in the "OFF" position before changing the switch condition.**

- 1) Apply parking brake
- 2) Confirm vehicle is not in the default shipping state or "Inventory position" as shown below. Failure to confirm vehicle has been removed from this state will result in loss of normal vehicle operation.
- 3) Locate Extended Storage Switch in cabin fuse block. Confirm it is in the "Customer" position. See below for reference.

a) To remove transit mode (Fuse Block):

1. Remove fuse cover lid.
2. Push down shorting pin.
3. Ign On 2 times without starting the vehicle.

b) To remove transit mode (BCM):

1. Confirm ignition switch is in "OFF" position.
2. Simultaneously push the signal and wiper switch fully down for two (2) seconds.

NOTE: While in BCM Transit Mode, turn signal indicators will remain illuminated for one minute.

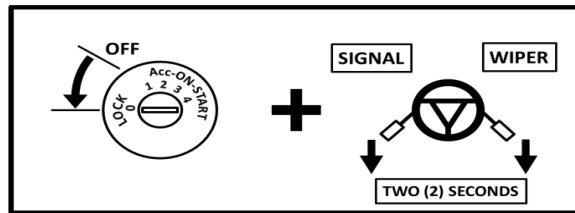
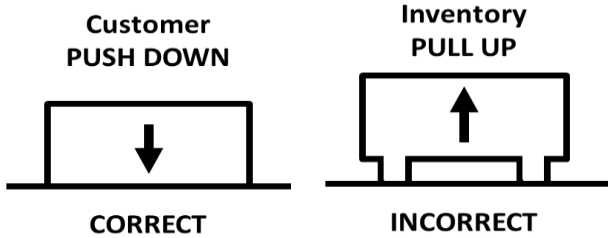

c) To return to transit mode for storage:

1. Ign Off.
2. Remove fuse cover lid.
3. Pull up shorting pin.
4. Assemble fuse cover lid.
5. Ign On 2 times without turn the vehicle on.
6. Confirm transit mode condition on meter

NOTE: Typical vehicle condition shown above. Switch is easily identifiable by the permanent, push-pull fuse holder. Actual position on the fuse block may vary, vehicle to vehicle.

Condition	Switch Position	Note
Vehicle is delivered to the dealer	Inventory Condition	
Technician performs PDI	Customer Delivery	Return to Inventory position after PDI.
Customer test drives the vehicle	Customer Delivery	Return to Inventory position after test drive.
Vehicle is being stored at the dealer	Inventory Condition	
Vehicle is delivered to customer	Customer Delivery	

NOTE: The Extended Storage Switch is only an aid to improve battery life during vehicle storage at the dealer. If the Extended Storage Switch fuse ever needs service after vehicle delivery, discard the Extended Storage Switch and install the correct fuse in its place.

- 4) Turn ignition switch to "ON" position
- 5) Record the customer radio presets and other presets as required.

Preset	1	2	3	4	5	6		

- 6) Put shift lever in "P" position for A/T and CVT or "1st" for M/T
- 7) Turn ignition switch to "OFF" position
- 8) Use seat and floor protection.

INSTALLATION PROCEDURE: PRE-INSTALLATION CAUTIONS / NOTES

⚠ CAUTION

- Allow 3 min after key off and doors closed for vehicle to time out. Allow an additional 3 min after negative terminal dis-connect before separating any electrical connectors.

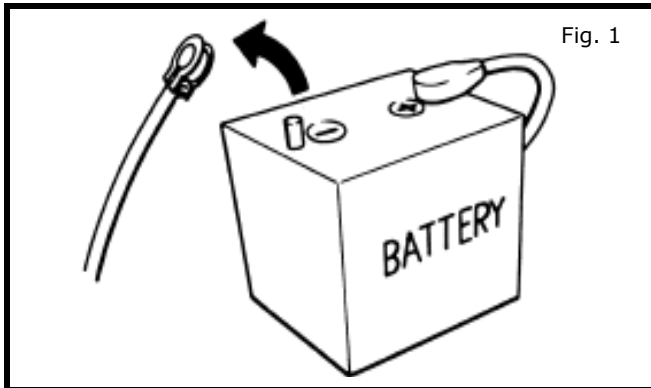

- 7) Disconnect the negative battery terminal as shown in Fig. 1.
- 8) Use seat and floor protection.
- 9) This part is to be installed at surface temperature of 65-100 deg.F.

⚠ CAUTION

- Take care not to scratch or damage any component during the removal or re-installation process.
- Trim pieces found to have witness marks or broken clips are not to be reinstalled.
- Additional items in cargo area may need to be removed.
- Always remove vehicle parts in the sequence they are shown, improper procedure can damage parts.
- Store removed parts in a safe and protected manner.

INSTALLATION OVERVIEW:

1.) SYSTEM

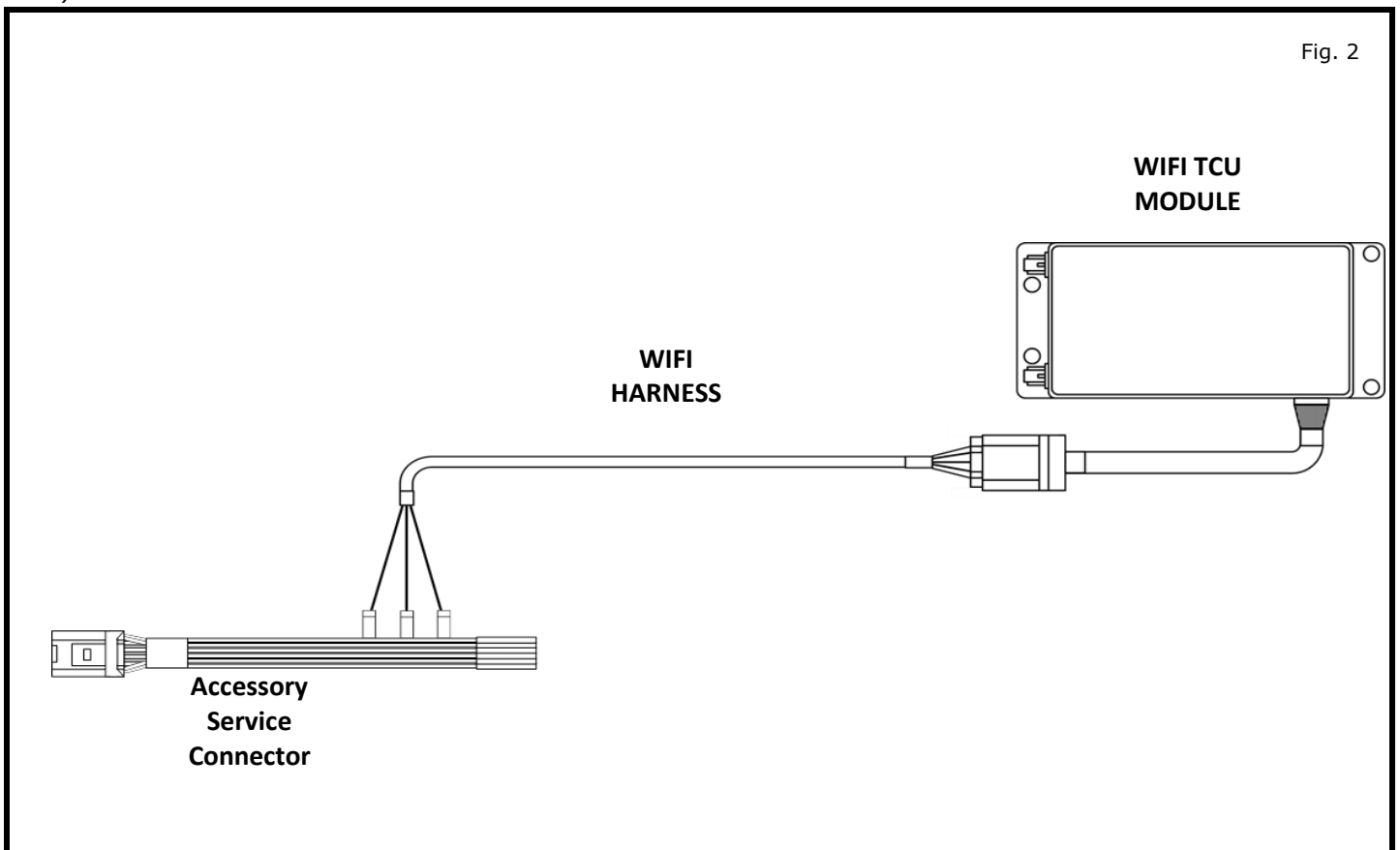

INSTALLATION OVERVIEW:

2.) VEHICLE

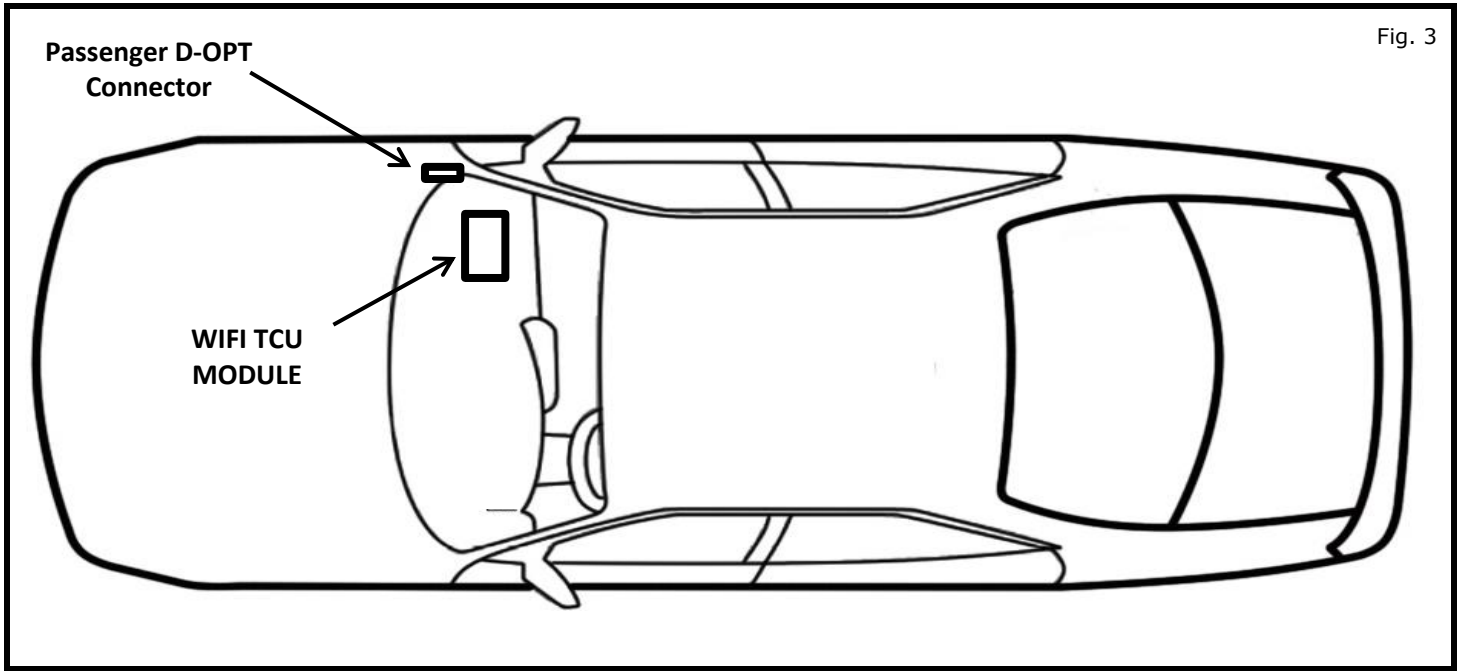

⚠ CAUTION

- Any description of vehicle wiring color is for reference only.
- Always refer to vehicle wiring diagram for details.

3) Routing

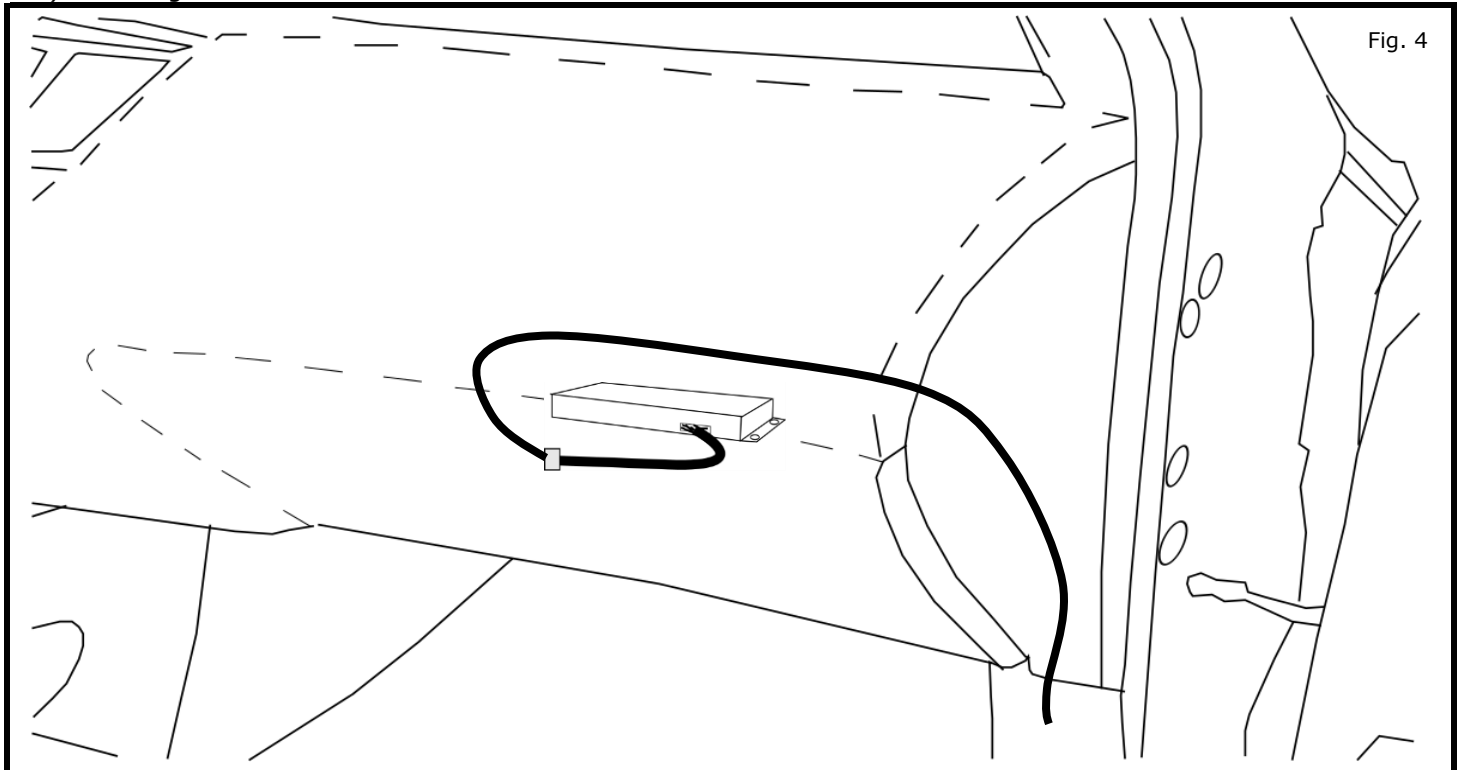

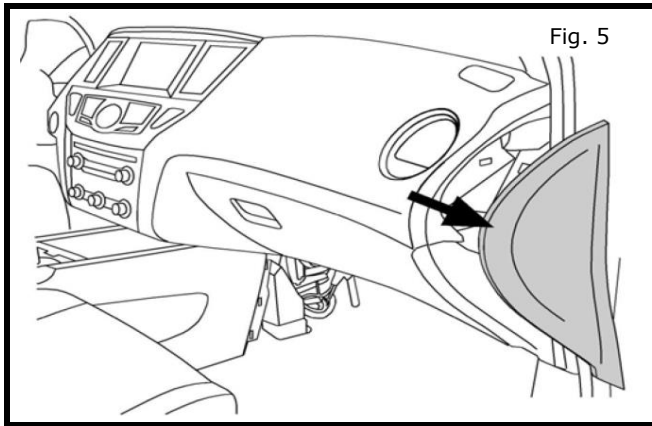
INSTALLATION PROCEDURE:**VEHICLE PARTS REMOVAL**

- 1) Removing the dash mask.
 - a) Carefully pry off passenger side dash mask as shown in Fig. 5 using a nylon trim tool.

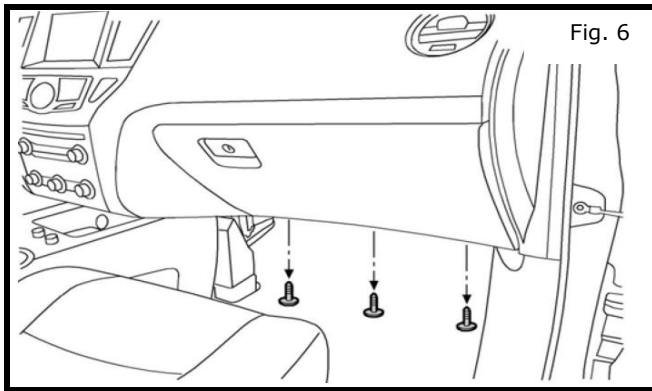

- 2) Removing glove box.
 - a) Remove three (3) phillips head screws from underside of the glove box as shown in Fig. 6.

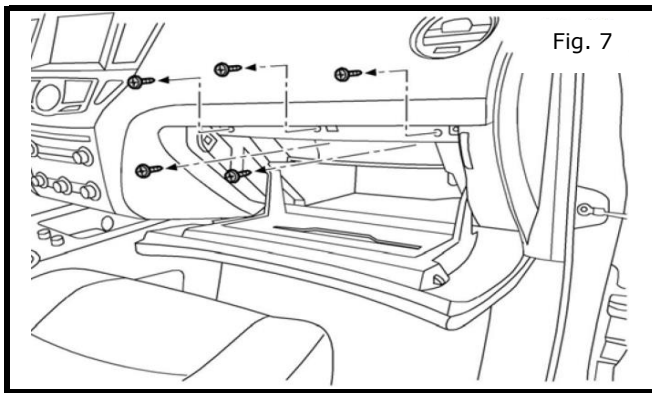

- 3) Removing glove box.
 - a) Open glove box door and remove five (5) phillips head screws from inside glove box compartment as shown in Fig. 7.

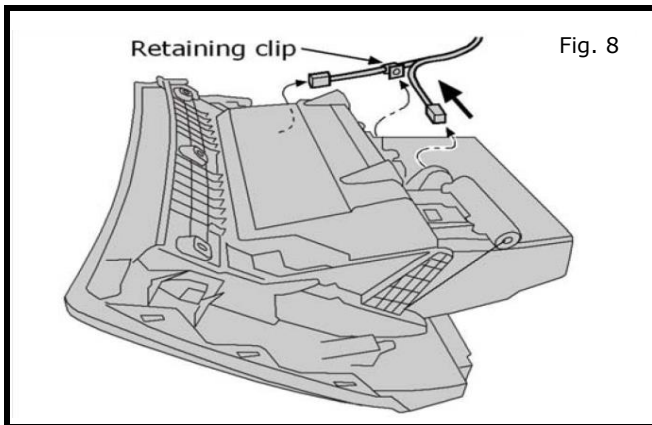

- 4) Removing glove box.
 - a) Carefully pull glove box assembly partially out, then gently detach clip and disconnect glove box lamp as shown in Fig. 8. Once fully removed, set glove box assembly aside.

NOTE:

Place glove box assembly on a protected work surface to avoid any scratches or damage.

INSTALLATION PROCEDURE:

VEHICLE PARTS REMOVAL

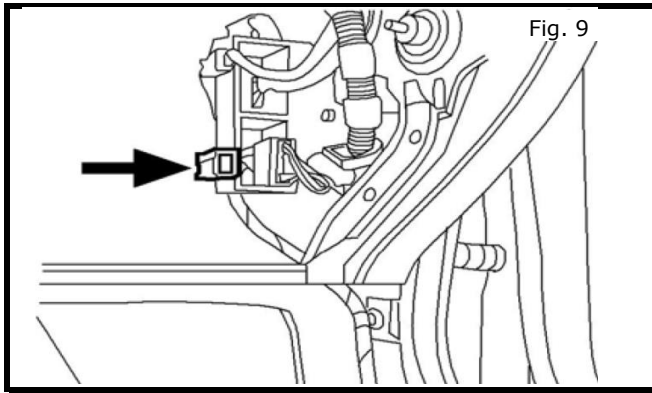

- 5) Locating Passenger Dealer Option connector
 - a) Locate passenger side D-OPT Connector plug behind glove box on right side of footwell as shown in Fig. 9.

Note:

- 1.) If there is already an Accessory Service Connector in passenger side read step 6, if not proceed to step 7.
- 2.) If there is not an Accessory Service Connector in passenger side remove the plug in connector.

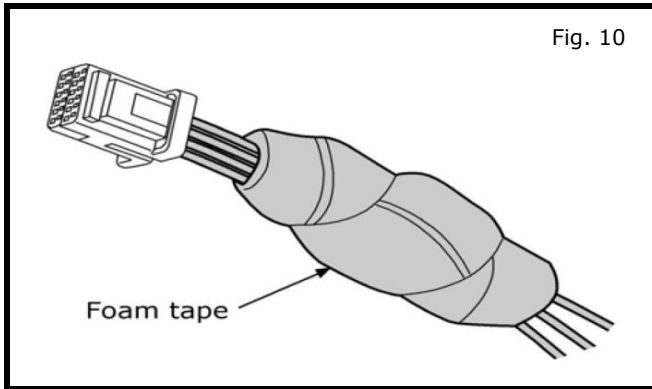

- 6) Locating Accessory Service Connector
 - a) If there is already an Accessory Service Connector in the passenger side remove it before continuing.
 - b) Remove any foam tape present before adding any positaps as shown in Fig. 10.

Note: If there is not an Accessory Service Connector present in the passenger side connector order from service dept.

Fig. 11

999Q9 AY000		
Pin	Label	Color
1	BAT	RED
2	N/A	N/A
3	ACC	ORANGE
4	N/A	N/A
5	BAT_SVR	PINK
6	DOOR_SW	GRN
7	THRU_SIGNAL 1	DK BLUE
8	THRU_SIGNAL 2	LT BLUE
9	N/A	N/A
10	RM LMP	YELLOW
11	N/A	N/A
12	GND	BLACK

- 7) Accessory Service Connector Reference
 - a) The accessory service connector pin out is shown in Fig. 11.

Notes:

- For direction on how to posi-tap refer to steps 11 - 21.
- For additional circuit information refer to the mech drawing at the end of the installation instructions.

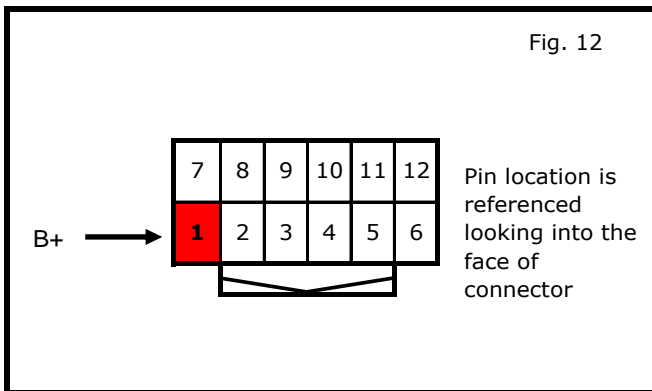

- 8) Posi-tap B+
 - a) Tap **Red** wire on the WiFi TCU Module harness to the Red (B+) wire on the Accessory Service Connector as shown in Fig. 12.

INSTALLATION PROCEDURE: POSI-TAP

Fig. 13

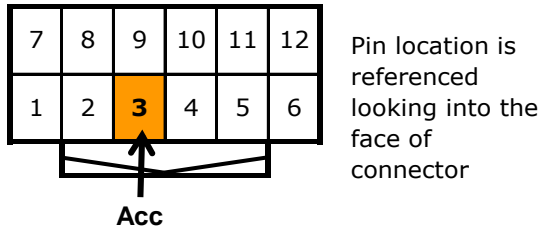

- 9) Posi-tap ACC
 a) Tap **White** wire on WiFi TCU Module harness to the Orange (Acc) wire on Accessory Service Connector as shown in Fig. 13.

Fig. 14

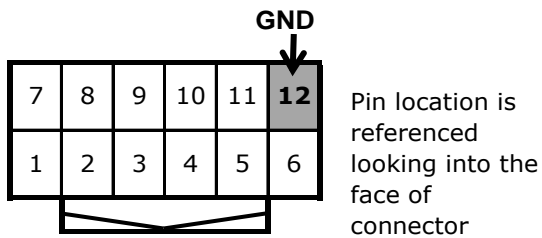

- 10) Posi-tap GND
 a) Tap **Black** wire on WiFi TCU Module harness to Black (Gnd) wire on Accessory Service Connector as shown in Fig. 14.

NOTE:
Figures are not to scale.

Fig. 15

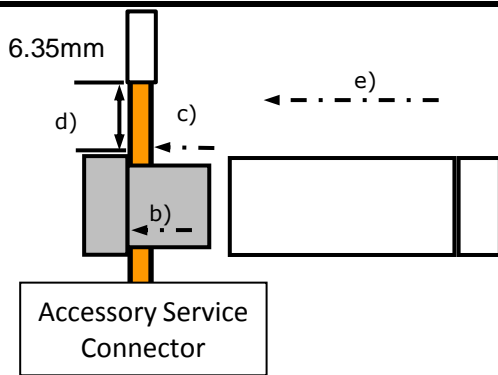

- 11) Posi-tapping an Accessory service wire (Fig. 15)
 a) Identify and confirm correct wire in Accessory Service Connector to be tapped.
 b) Remove cap (slot side) from tap body.
 c) Slide cap around single accessory wire.
 d) Position cap $\geq 6.35\text{mm}(0.25\text{in})$ away from heat shrink end of Accessory Service Connector (measurement for first posi-tap installed on circuit).
 e) Tighten the tap **TIGHT** with finger pressure.
 f) Tighten by another quarter turn.

Fig. 16

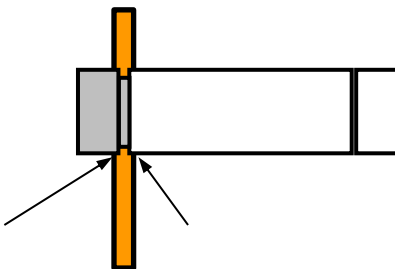

- i. Straight and evenly spaced all the way around
 ii. **Tighten** and **minimize** gap (wire jacket should

- 12) Inspecting the tap for correct installation (Fig. 16).
 a) Pull on the wire lightly to ensure connection.
 b) Inspect the tap to ensure correct installation.
 c) Test the signal to ensure that it is working

NOTE:
Avoid putting pressure on the vehicle wire and tap for the remainder of the installation.

INSTALLATION PROCEDURE: POSI-TAP

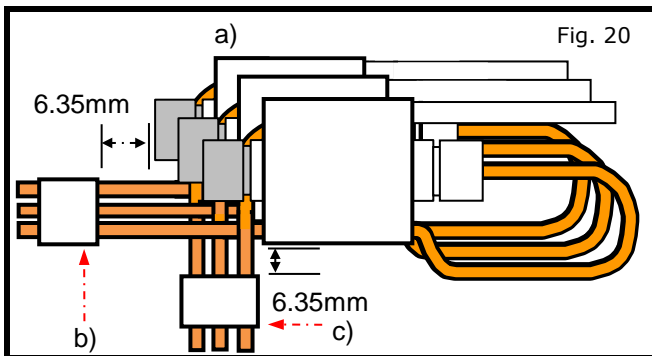
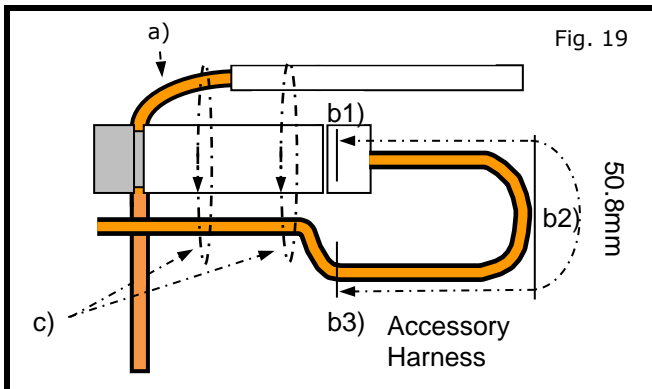
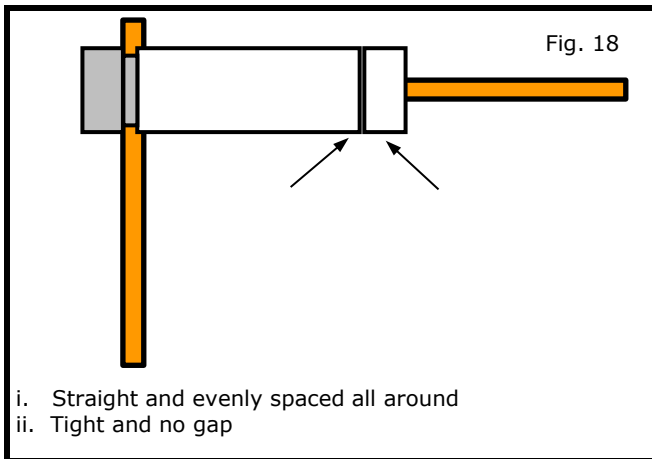
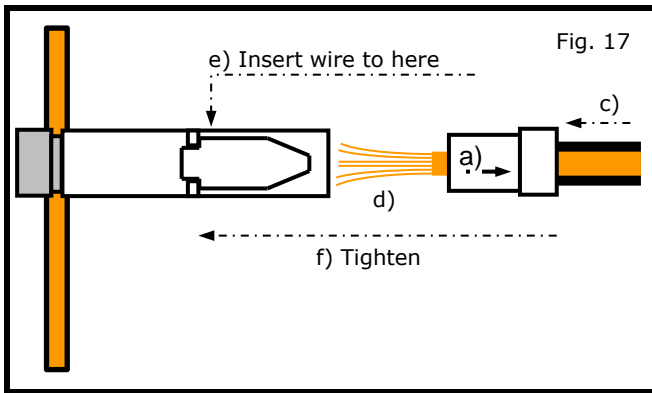

- 13) Tap accessory wire (Fig. 17).
 - a) Remove tap (non-pierce) side from tap.
 - b) Remove the protective stub from the wire.
 - c) Insert wire through the non-pierce side opening.
 - d) Spread the individual strands into fan shape.
 - e) Insert wire into tap body and ensure that it is all the way in.
 - f) Tighten the tap **TIGHT** with finger pressure.
 - g) Tighten by another quarter turn.

- 14) Confirm the tapped accessory wire.
 - a) Pull on wire lightly to ensure connection.
 - b) Inspect tap to ensure correct installation as shown in Fig. 18.

- 15) Forming strain relief loop - required (Fig. 19).
 - a) Gently bend end of pierced wire (where it exits cap) down towards body of posi-tap.
 - b) On tapped wire of non-pierce side; starting at point b1), measure 50.8mm(2in) to point b3). Make first bend of loop b2), half distance measured 25.4mm(1in), and up toward body of posi-tap, make second bend of loop b3).
 - c) Secure pierced wire on heat shrink side and tapped wire on non-pierce side to body of tap with electrical tape (≥ 2 revolutions).

- 16) Securing multiple accessory taps (Fig. 20).
 - a) Tapped accessories (wires already secured to tap bodies) are stacked slightly staggered on top of each other as shown in Fig a).
 - b) Tapped wires on non-pierce side of all posi-taps are secured to each other with electrical tape (≥ 2 revolutions) at a distance of $\geq 6.35\text{mm}$ (0.25in) as shown in Fig b).
 - c) Pierced wires of first and subsequent posi-taps are secured to each other with electrical tape (≥ 2 revolutions) at a distance of $\geq 6.35\text{mm}$ (0.25in) as shown in Fig c).

INSTALLATION PROCEDURE: POSI-TAP

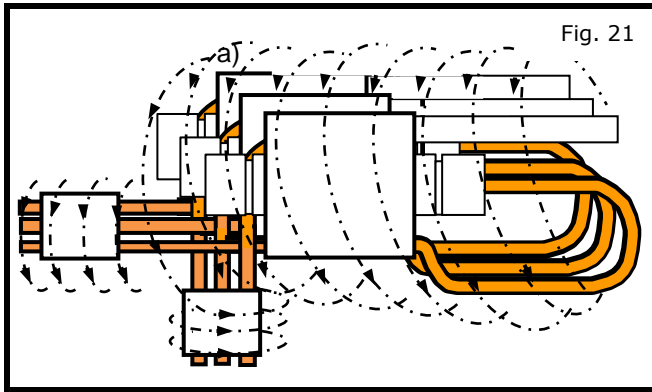

- 17) Pre- foam protective wrap
- a) Starting at heat shrink; firmly wrap posi-tap bundle with electrical tape or non-adhesive wire harness tape, making sure to overlap previous revolution as shown in Fig. 21.

Note:

If using a non adhesive tape to wrap the bundle, secure at both ends with ≥ 2 revolutions of adhesive electrical tape.

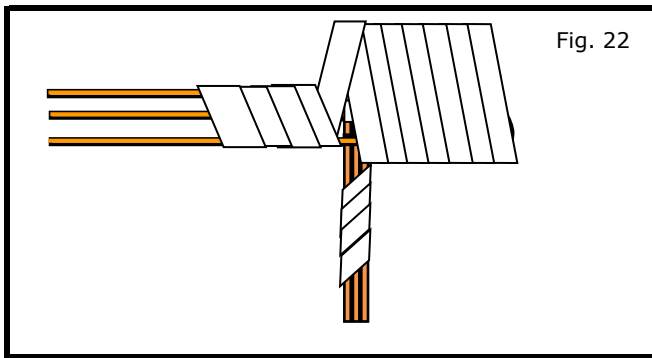

- 18) Finished protective wrap
- a) Make sure the finished wrap looks similar to Fig. 22.

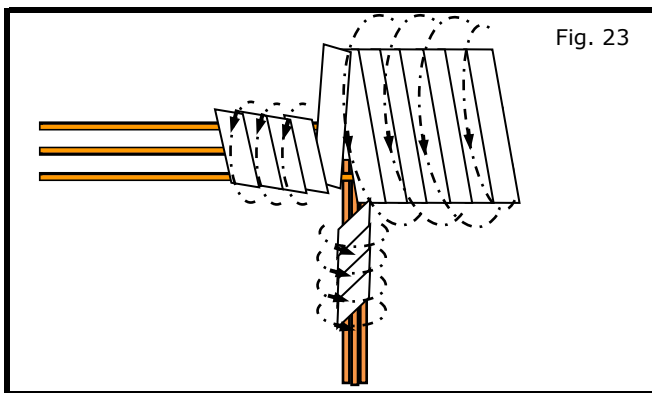

- 19) Foam wrap for posi-tap bundle (foam strips)
- a) Wrap posi-tap bundle with foam tape, following a pattern similar to electrical tape, making best use of foam strips provided as shown in Fig. 23.

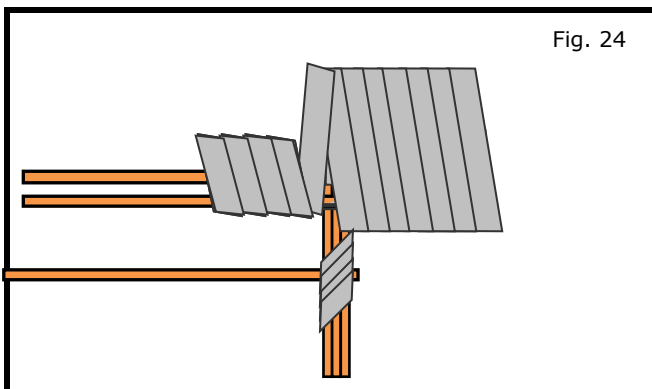

- 20) Finished foam wrap for bundle (strips-top view)
- a) Make sure finished wrap looks similar to Fig. 24.

INSTALLATION PROCEDURE: POSI-TAP

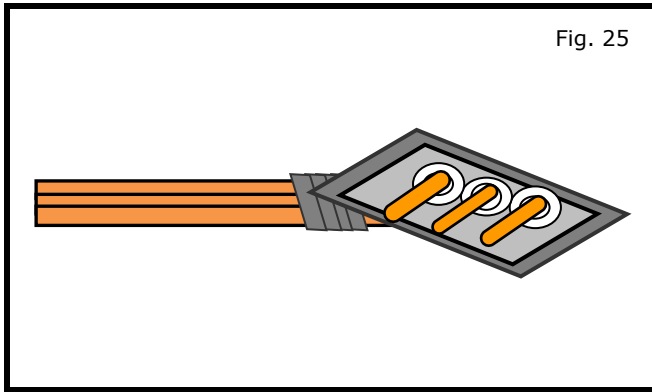

- 21) Finished foam wrap for bundle (strips-side view)
- Make sure finished wrap looks similar to what is shown in Fig. 25.

CAUTION

This Accessory Service Connector is for use only with Genuine Nissan (or Infiniti) or Nissan (or Infiniti) approved accessories. Use of this connector with non Genuine Nissan (or Infiniti) or Nissan (or Infiniti) approved accessories or failure to follow the installation instructions for the connector contained in this package may result in damage to the accessory and/or your vehicle. Nissan (or Infiniti) is not liable for loss or damage due to improper installation or the installation of non Genuine or non approved accessories.

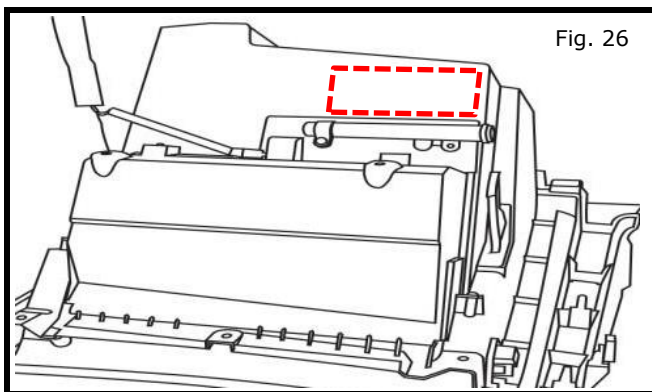

- 22) Prepping surface for mounting WiFi module.
- Clean glove box installation surface and WiFi base plate with an alcohol wipe.

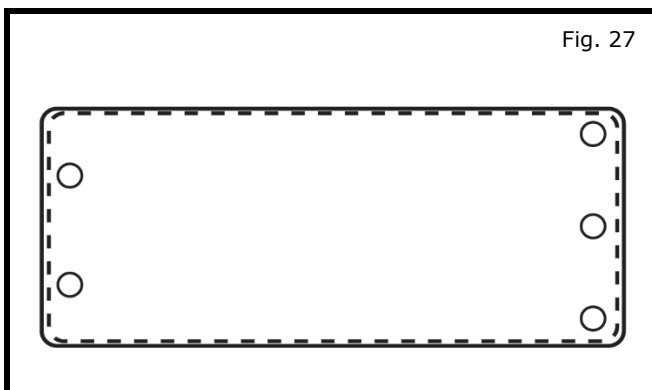

INSTALLATION PROCEDURE: WIFI MODULE

Fig. 28

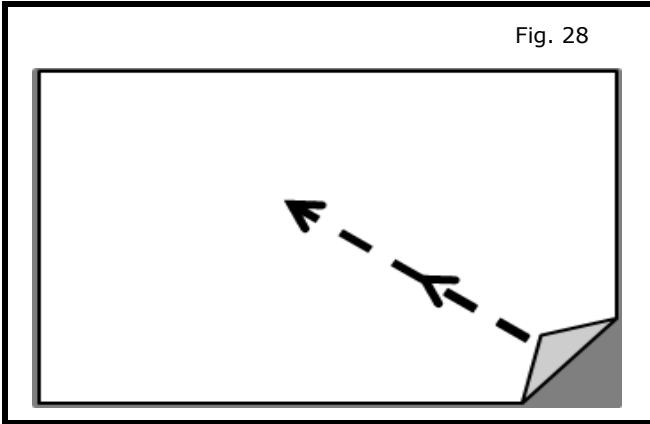

23) Module Installation

- a) Peel tape liner off of adhesive square as shown in Fig. 28.

Fig. 29

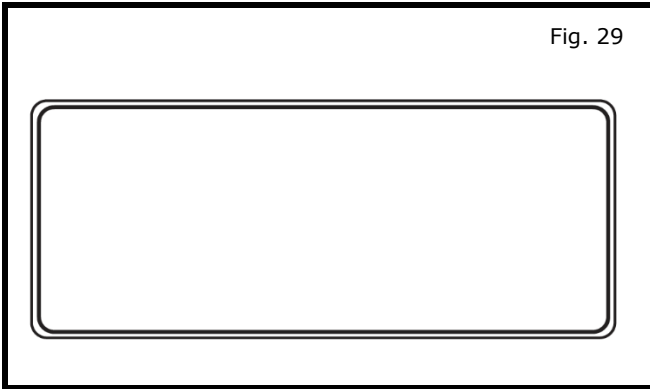

24) Module Installation

- a) Apply double sided tape to base plate of the WiFi module as shown in Fig. 29.

Fig. 30



25) Module Installation

- a) Peel tape liner from foam pad on module as shown in Fig. 30.

Fig. 31

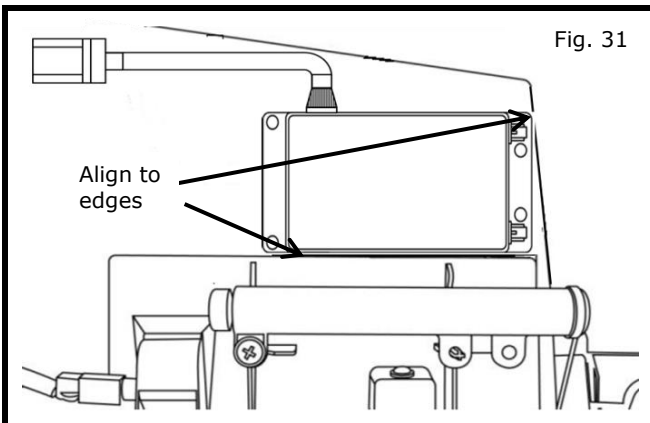

26) Module Installation

- a) Adhere module to top of glove box as shown in Fig. 31. Align the edge of the WiFi module with the glove box return platform. Align the WiFi module so it is even with the right side edge of the glove box. Press WiFi module to glove box with 15lbs min. pressure.

INSTALLATION PROCEDURE: WIFI MODULE

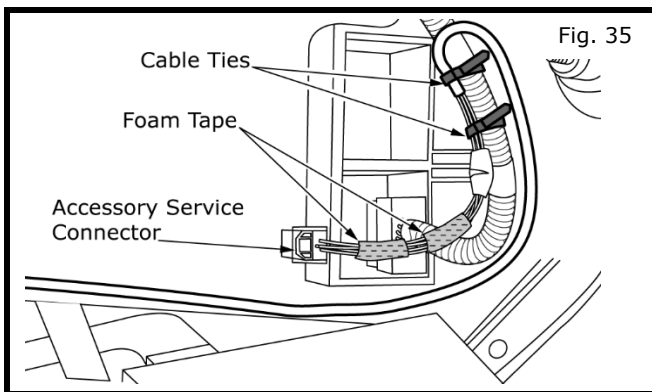
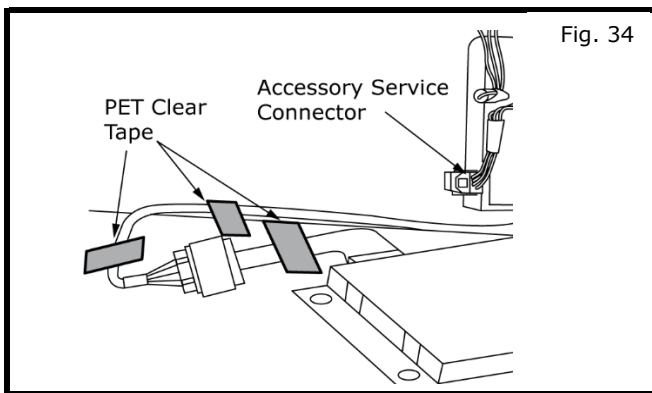
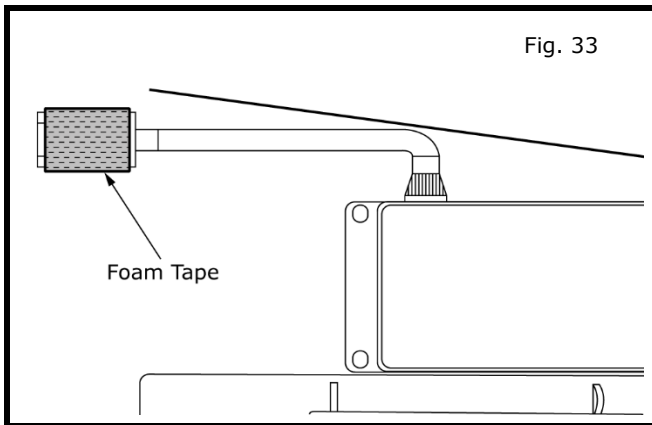
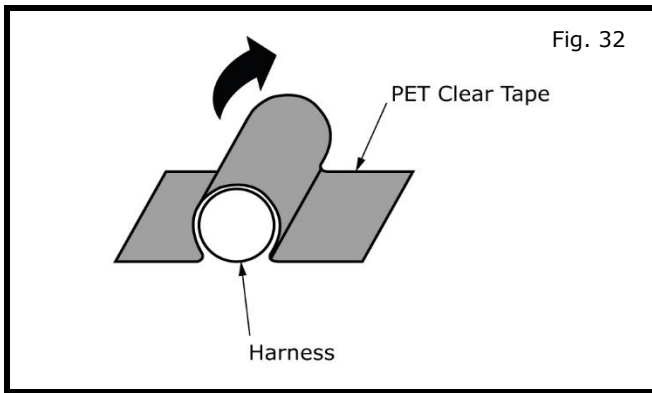

NOTE:

Ensure PET clear tape is attached up and over harness as shown in illustration.

- 27) Module Installation
a) Male connector is wrapped in foam tape.

Module Installation

- 28) a) Connect Positapped Accessory Service Connector to Pass D-OPT connector as shown in Fig. 34.
b) Connect harness to WiFi module as shown in Fig. 34.
c) Secure WiFi module harness to top of glove box with Pet clear tape in 3 places as shown in Fig. 34. Flat side down for connector.

- 29) Module Installation
a) Push posi-taps to rear of vehicle wire harness.
b) Secure WiFi module harness to vehicle harness with 2 cable ties as shown in Fig. 35. Foam tape as needed for rattle.

INSTALLATION PROCEDURE: WIFI MODULE

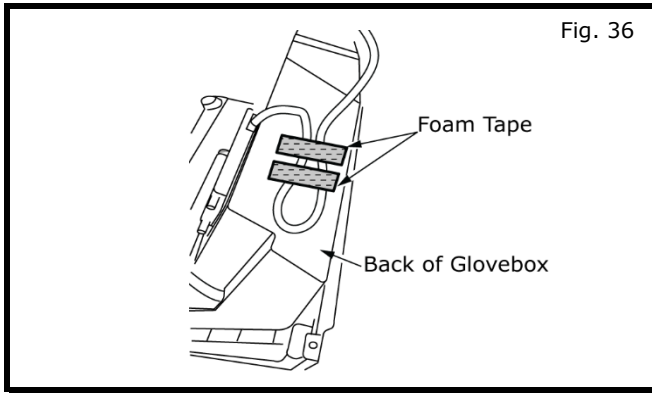

- 30) Make service loop as shown in Fig. 36 and secure with foam tape in 2 places. Length of WiFi harness should be **590mm** from last cable tie to WiFi harness connector.

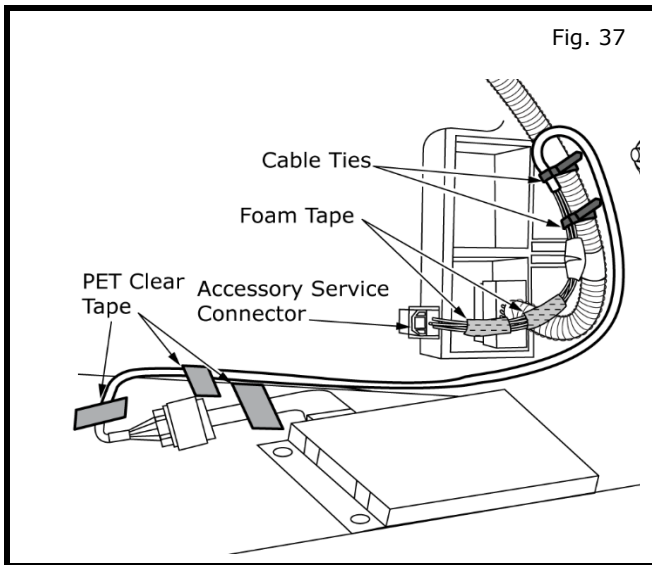

- 31) Module Installation
- a) When finished the routing should be similar to that as shown in Figs. 36 & 37.
- b) Reassemble all assemblies. Proceed to page 14 for final assembly check list and page 15 & 16 for the WiFi module test.

FINAL INSPECTION:

CAUTION

Use caution when re-installing interior components to avoid damage, scratches, or breaking of mounting clips. Refer to the vehicle service manual for more information.

- Inspect the installation area for any debris.
- Make sure all trim clips are in their retainers and gently press the trim panels into place.
- Verify re-installed trim parts for proper flush fit (no gap, no waviness, etc.).
- Verify all clips are fully engaged and locked.
- Verify re-installed trim parts are free from cracks, scratches or stress marks.
- Verify vehicle headliner, seat, steering wheel, center console, floor carpets, etc. are not soiled.
- Verify interior and exterior is not damaged.
- Connect the battery negative terminal and tighten the nut to 5.4 N-m (47.8 lb-in).
- Turn ignition switch to "OFF". Wait 10 seconds, then switch to "ON".
- Turn ignition switch to "ON" and confirm proper operation of vehicle systems and verify:
- Re-program radio presets and other vehicle settings to the recorded settings.
 - Confirm proper audio function (AM, FM, SAT, CD and AUX).
 - That there are no new Diagnostic Trouble Codes.
 - Verify all windows and sunroof (if equipped), one touch operation and perform the reset procedure if necessary. Refer to the vehicle service manual for more details.
 - Power Back Door (If equipped). - Turn on the car, push and note if trunk opens.
 - Tail Lamp - Turn on headlamps; open glove box and note whether light goes on.
 - Start vehicle. Note whether vehicle starts.
- Front Sonar Module Connector - Turn on vehicle, put vehicle in 'Drive'. Move slowly towards a large object in front of the vehicle. Note whether alarm sounds.
- Rear Sonar Module Connector - Turn on vehicle, put vehicle in 'Reverse'. Move slowly towards a large object behind the vehicle. Note whether alarm sounds.
- Place the Owner Manual, Quick Reference Guide, and/or other Manual in the glove box.

FINAL INSPECTION: CHECK OUT

- Turn your car to the ACC position to power up the WiFi module. Wait 3 minutes.
- Open your wireless network list and connect to "Autonet-XXXX" (The last 4 digits will be the last 4 digits of the WiFi serial number).
- Open your browser the following screen appears.

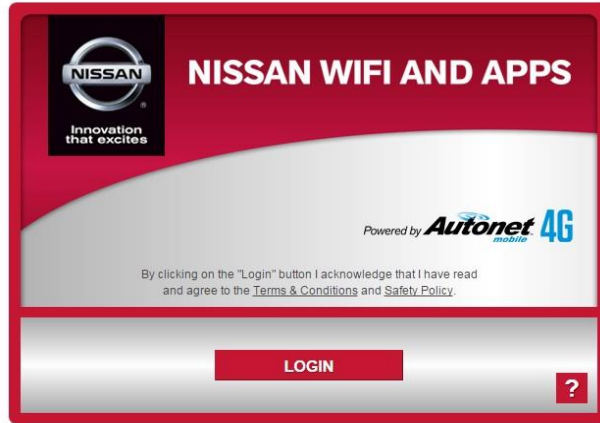

Autonet assumes no responsibility for the configurations, security, or data files on your wireless device resulting from connection to Autonet's network. Anti-virus, privacy, and security protection is the responsibility of the user.
Autonet Mobile recommends that the driver of this vehicle should not attempt to use this system while driving the vehicle.
Do not operate any function that takes your attention away from safely driving your vehicle. Any function that requires prolonged attention should be performed after coming to a complete stop. Always stop the vehicle in a safe location before performing these functions. Failure to do so may result in an accident.
Copyright © 2008 - 2015 Autonet Mobile, Inc. All Rights Reserved.

- Click the LOGIN button. If the following screen appears showing no signal while trying to log in there is insufficient cell tower signal. The vehicle may have to be moved outside for better reception.



If you are unable to see the "Autonet-XXXX" in your wireless network list verify power is present to the WiFi module. If power is present and module still does not appear on the wireless network list call Autonet Mobile at 1-800-977-2107

FINAL INSPECTION: CHECK OUT



After pressing the 'Login', the following window will open, the WiFi module is now in communication with the cell tower. Installation is complete.

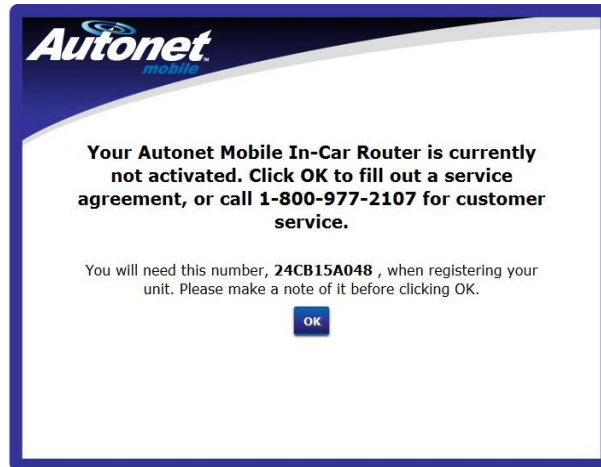

The test verifies data communication via network/telecommunication as indicated by prompting the user to fill out a service agreement.

If the service agreement does not pop up this indicates that the Telecommunications (WiFi/network) failed. Contact Autonet Mobile at 1-800-977-2107



Place the Activation Guide, and glove box brochure in the glove box.

Posi-Tap™ is protected by patent # 5,228,875 5,695,369 5,868,589 6,692,313 Jap 2881414 Aus 708700 Tia 103534 Can 2204826 Mex 200626 Korea 477279 China Z197105562.9 & others pending.

WIFI

PASSENGER SIDE

ACCY_SER_CONN



TH12FW-NH

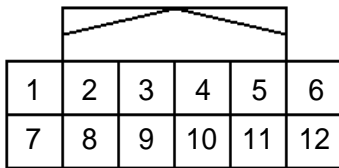

Note: Pin location is referenced looking into wire side of connector.

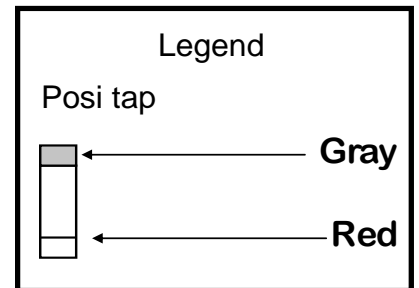

CAUTION

This Accessory Service Connector is for use only with Genuine Nissan (or Infiniti) or Nissan (or Infiniti) approved accessories. Use of this connector with non Genuine Nissan (or Infiniti) or Nissan (or Infiniti) approved accessories or failure to follow the installation instructions for the connector contained in this package may result in damage to the accessory and/or your vehicle. Nissan (or Infiniti) is not liable for loss or damage due to improper installation or the installation of non Genuine or non approved accessories.