



GENUINE PARTS

INSTALLATION INSTRUCTIONS

| | |
|---------------------|------------------------|
| DESCRIPTION: | Mooroof Wind Deflector |
| APPLICATION: | Nissan Sentra |
| PART NUMBER: | 999D4 LZ000 |

KIT CONTENTS:

| Item | Qty. | Part Description | Service Part Number |
|------|------|--|---------------------|
| A | 1 | Moonroof Deflector | 999D4 LZ000SP |
| B | 4 | Screw | |
| C | 4 | Nylon Washer | |
| D | 4 | Nylon Nut | |
| E | 2 | Side Bracket | |
| F | 2 | Front Bracket | |
| G | 4 | Protective Tape | |
| H | 5 | Installation Instructions Replacement Template | |

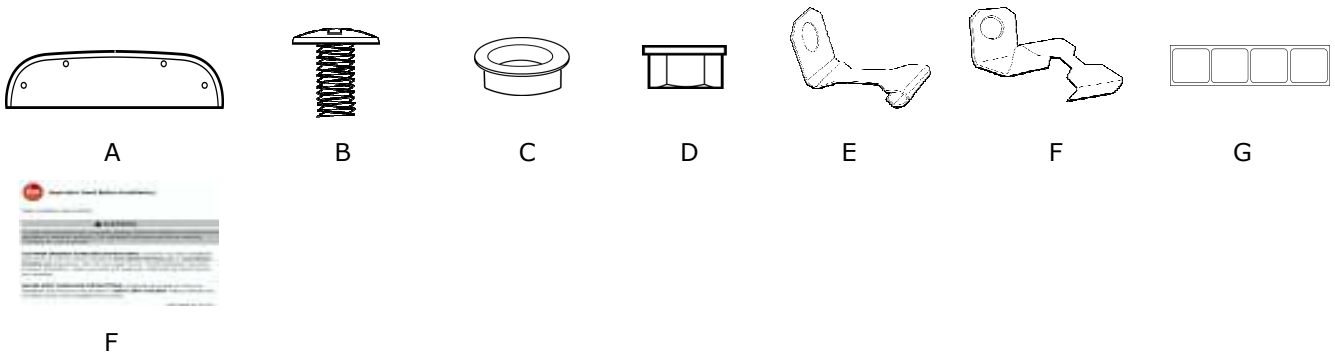

TOOLS REQUIRED:

- Rubbing Alcohol (90% or greater)
- #2 Phillips Head Screw Driver
- Car Wash Supplies
- Measuring Tape or Scale
- Felt Tip Pen
- Masking Tape
- Shop Towel
- 10mm Wrench

PRE-INSTALLATION WARNINGS, CAUTIONS, CRITICAL STEPS, and NOTES:

- Dealer Installation Recommended. Instructions may refer to Service Manual.
- To avoid damaging the surface, never use ammonia-based cleaners or solvents to clean your moonroof deflector.
- Clean moonroof deflector with a solution of mild dishwashing soap and water using a soft cloth or
- To remove fine scratches and restore the original luster, use a high quality plastic cleaner.

INSTALLATION PROCEDURE:

- 1) Clean roof installation area.
- 2) Open moonroof.
- 3) Clean inner edge (flange) of moonroof opening using rubbing alcohol and shop towel. Make sure to clean backside of flange.

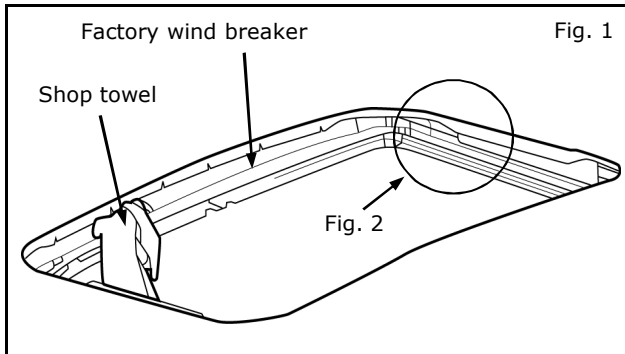

- 4) Push factory wind breaker down and insert shop towel to hold it in place.

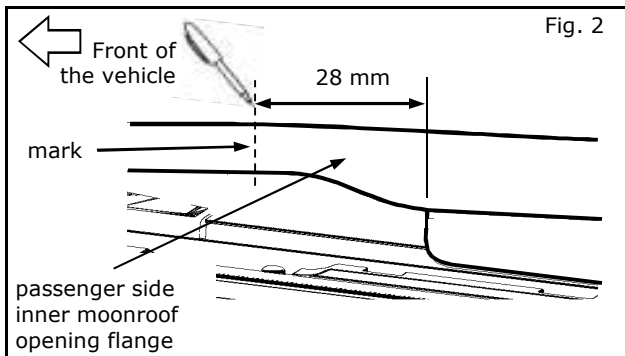

- 5) Measure 28mm forward from edge shown on passenger side inner moonroof opening flange and mark location on flange using felt tip pen. Repeat for driver side.

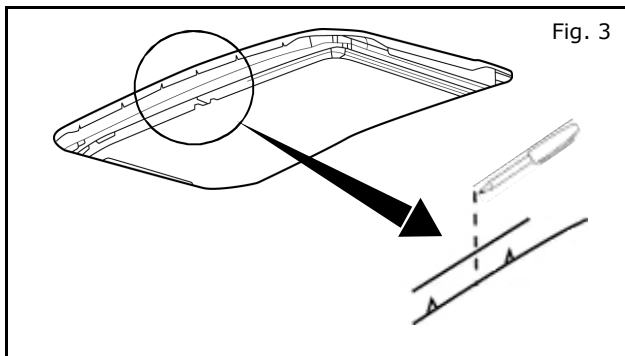

- 6) Locate the center of the moonroof opening.

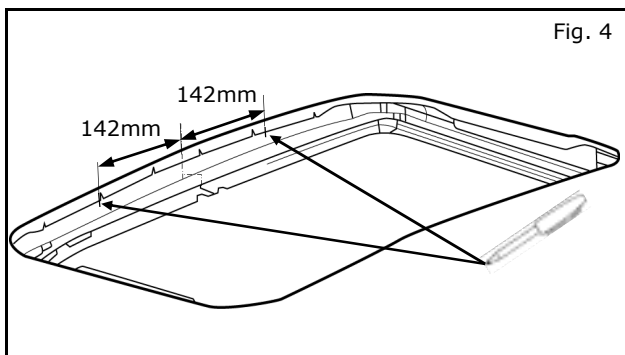

- 7) From the center mark measure 142mm to each side and mark a line on the flange using a felt tip pen.

INSTALLATION PROCEDURE (CONTINUED):

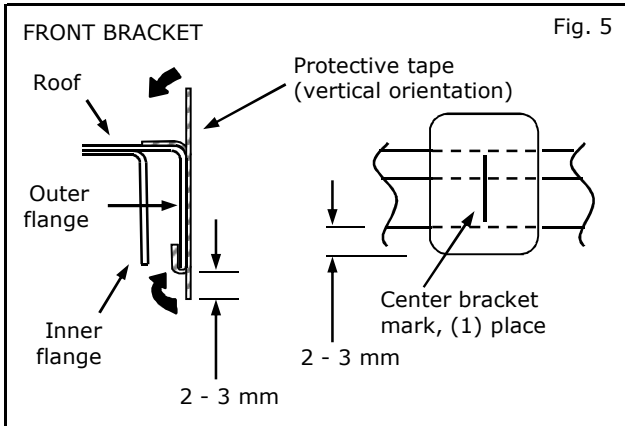

- 8) Center protective tape on lines at (2) front locations.

NOTE:

Make sure protective tape is smooth and free of wrinkles.

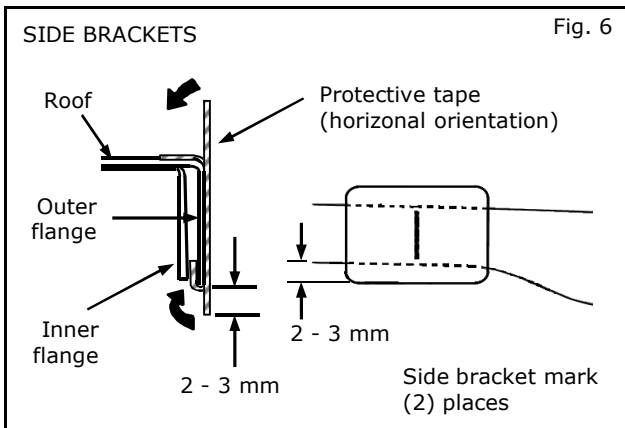

- 9) Center protective tape on lines at (2) side locations.

NOTE:

Make sure protective tape is smooth and free of wrinkles.

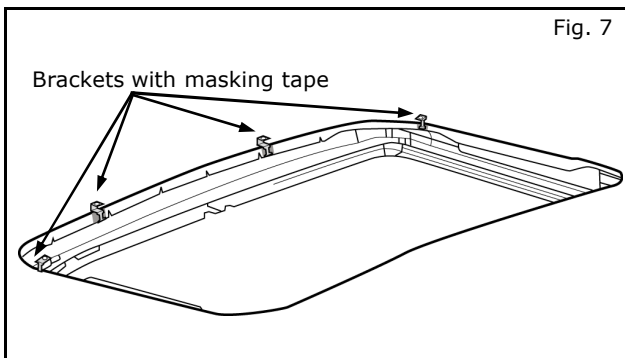

- 10) Center brackets on protective tape and secure in place using masking tape.

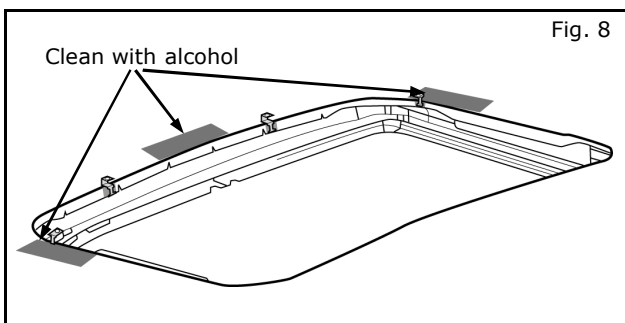

- 11) Clean areas shown using rubbing alcohol 90 % or greater.

NOTE: Allow enough time for alcohol to evaporate.

INSTALLATION PROCEDURE (CONTINUED):

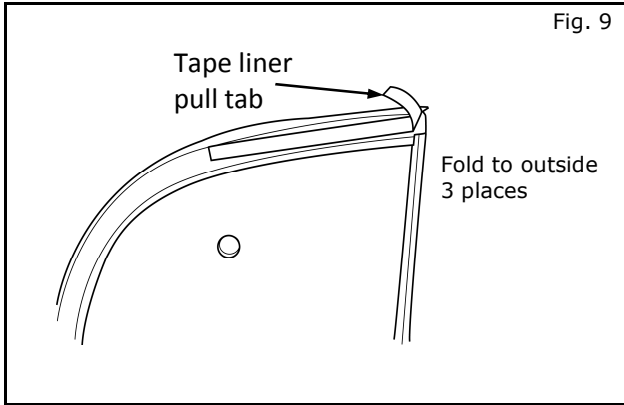

- 12) Fold tape liner pull tabs to outside of deflector and tape in place.

NOTE: Ensure that adhesive tape under liner is not yet exposed.

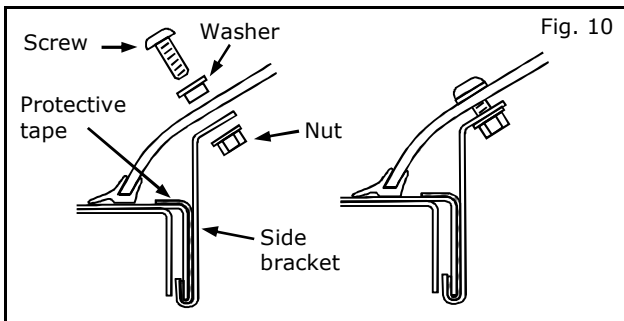

- 13) Set moonroof deflector on the roof so deflector holes are aligned with bracket holes.

- 14) Starting with side brackets, install washer and screw through deflector and bracket, loosely install nut.

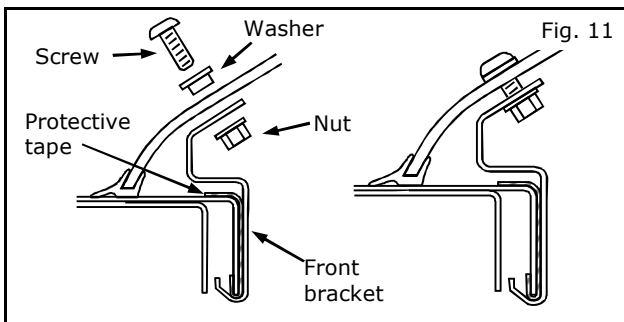

- 15) Repeat step 14 for front brackets.

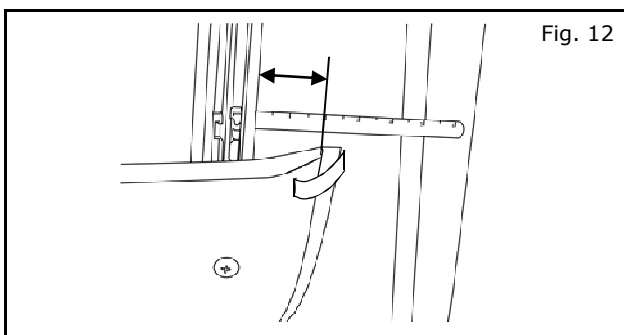

- 16) Verify with scale that deflector is located evenly on both sides of opening.

CAUTION

Leaving air gap between brackets and flange can cause wind noise issues. Confirm there is no gap between brackets and flange. If there is any gap, adjust deflector and side brackets forward to eliminate gap. (Fig.11)

INSTALLATION PROCEDURE (CONTINUED):

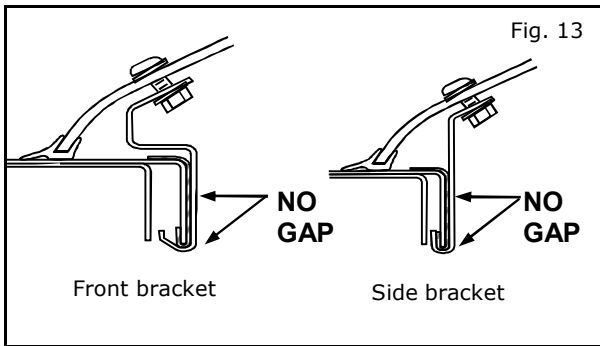

- 17) Push forward to eliminate any gap between center bracket and flange.



CAUTION

Leaving air gap between brackets and flange can cause wind noise issues. Confirm there is no gap between brackets and flange. If there is any gap, adjust deflector and side brackets forward to eliminate gap.

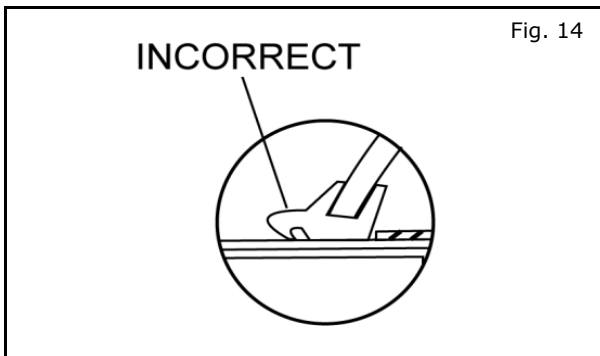

- 18) Check that rubber seal is not twisted or rolled under deflector. If necessary, slide a credit card under rubber seal and remove to straighten it.

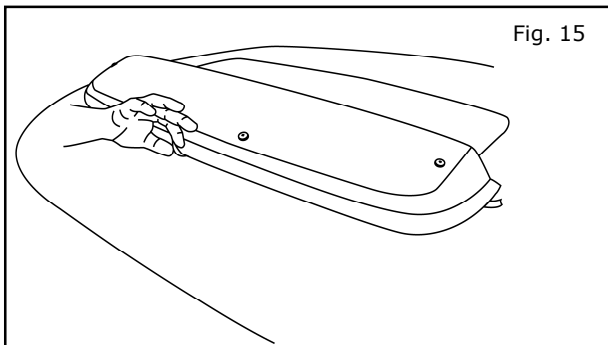

- 19) Pull tape liner of center tape.

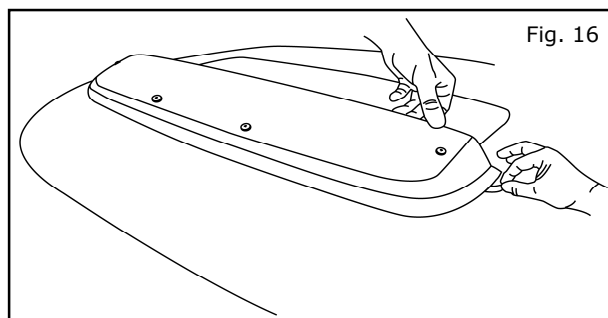

- 20) Fully tighten front bracket screws.
NOTE: To prevent damage to nylon nuts, do no overtighten.
- 21) Carefully lift rear of moonroof deflector and pull out tape liners at both sides.
NOTE: Take care not to cause any gaps between brackets and roof flange.

INSTALLATION PROCEDURE (CONTINUED):

22) Fully tighten side bracket screws.

NOTE: To prevent damage to nylon nuts, do not overtighten.

23) Remove shop towels holding factory wind breaker down and close moonroof.

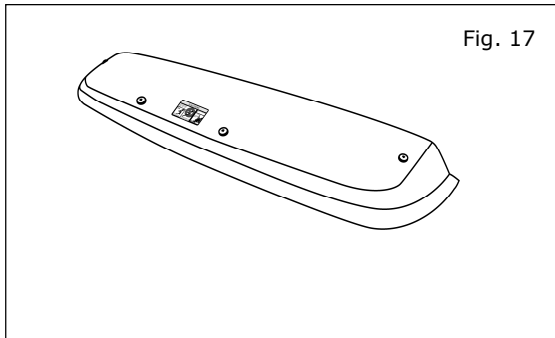

24) Peel off and discard "Caution Label" attached to top surface of deflector.

CHECKLIST:

Prior to completion, verify the following:

- Rubber seal is not rolled under deflector.
- Close moonroof to confirm it operates normally.