



GENUINE PARTS

INSTALLATION INSTRUCTIONS

DESCRIPTION:	Interior Accent Lighting Kit.
APPLICATION:	Murano
PART NUMBER:	999F3 C5000
REQUIRED FOR INSTALLATION:	999Q9 AY001 (Accessory Service Connector) - Not included in Accent Lighting Kit

Item	QTY	Part Description	Service Part Number
A	1	Control Module	Not Serviceable- Parts of Kit- 999F3 C5000
B	2	Front Footwell Lights and Harness Assembly	
C	1	Vehicle Interface Harness	
D	1	Hardware Kit	
E	1	Installation Instruction Replacement Template	

ITEMS NOT IN KIT THAT MAY BE REQUIRED

AA	1	Accessory Service Connector (ASC)	999Q9 AY001
----	---	-----------------------------------	-------------

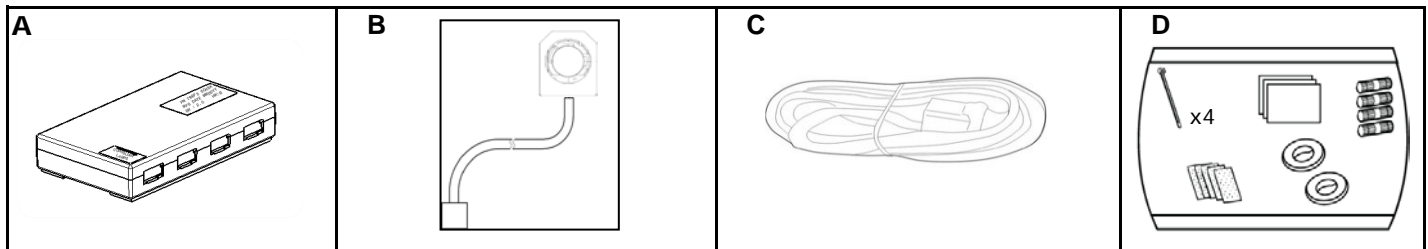

E

STOP Important: Read Before Installation

WARNING

Customer Safety Information:

To avoid a fire risk, please do not use the vehicle or stop it while working on the electrical system. The installation of the vehicle's electrical system is a safety-critical task. Please read the instructions carefully before starting the work. If you are unsure, please contact your dealer or a qualified electrician. Do not use the vehicle until you are satisfied with the work. The dealer is responsible for the correct installation of the vehicle's electrical system. ©2018 Nissan North America, Inc. NISSAN

AA

Note: 1 or 2 ASC may already be installed in the vehicle

TOOLS REQUIRED:

- Trim stick
- 7/32" Drill Bit
- 10mm Wrench
- Electrical tape
- 1/8" Drill bit
- Scissors
- Drill Motor
- Protective cloth
- 3/4" Drill bit

VEHICLE PREPARATION:

⚠ CAUTION

• Always confirm the ignition is in the "OFF" position before changing the switch condition.

- 1) Apply parking brake
- 2) Confirm vehicle is not in the default shipping state or "Inventory position" as shown below. Failure to confirm vehicle has been removed from this state will result in loss of normal vehicle operation.
- 3) Locate Extended Storage Switch in cabin fuse block. Confirm it is in the "Customer" position. See below for reference.
 - a) To remove transit mode (Fuse Block):
 1. Remove fuse cover lid.
 2. Push down shorting pin.
 3. Ign On 2 times without starting the vehicle.
 - b) To remove transit mode (BCM):
 1. Confirm ignition switch is in "OFF" position.
 2. Simultaneously push the signal and wiper switch fully down for two (2) seconds.

NOTE: While in BCM Transit Mode, turn signal indicators will remain illuminated for one minute.

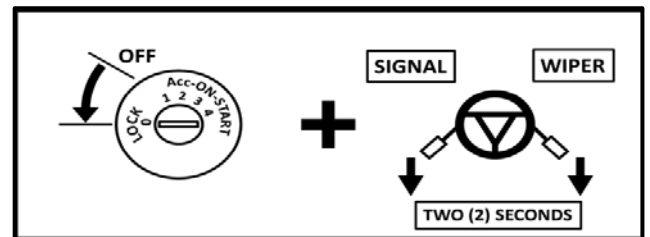
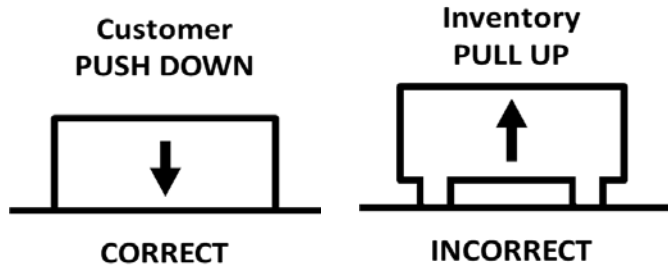

- c) To return to transit mode for storage:
 1. Ign Off.
 2. Remove fuse cover lid.
 3. Pull up shorting pin.
 4. Assemble fuse cover lid.
 5. Ign On 2 times without turn the vehicle on.
 6. Confirm transit mode condition on meter

NOTE: Typical vehicle condition shown above. Switch is easily identifiable by the permanent, push-pull fuse holder. Actual position on the fuse block may vary, vehicle to vehicle.

Condition	Switch Position	Note
Vehicle is delivered to the dealer	Inventory Condition	
Technician performs PDI	Customer Delivery	Return to Inventory position after PDI.
Customer test drives the vehicle	Customer Delivery	Return to Inventory position after test drive.
Vehicle is being stored at the dealer	Inventory Condition	
Vehicle is delivered to customer	Customer Delivery	

NOTE: The Extended Storage Switch is only an aid to improve battery life during vehicle storage at the dealer. If the Extended Storage Switch fuse ever needs service after vehicle delivery, discard the Extended Storage Switch and install the correct fuse in its place.

- 4) Turn ignition switch to "ON" position
- 5) Record the customer radio presets and other presets as required.

Preset	1	2	3	4	5	6		

- 6) Put shift lever in "P" position for A/T and CVT or "1st" for M/T
- 7) Turn ignition switch to "OFF" position
- 8) Use seat and floor protection.

PRE-INSTALLATION CAUTION/NOTES

- Dealer installation recommended. Instructions may refer to Service Manual
- Installation may require special tools
- This part is to be installed within a surface temperature range of 65-100°F

⚠ CAUTION

- This accessory must only be installed as specified in these instructions.
- Ensure at all times that parts are securely fitted and will not compromise the safe function of vehicle systems

INSTALLATION PROCEDURE:

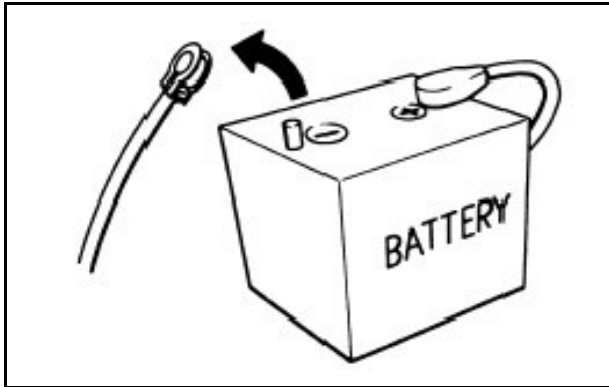

- 1) Turn ignition switch to "OFF" position
- 2) Disconnect the negative battery terminal.
 - a) Lower both the driver and passenger windows to prevent damage.
 - b) Disconnect the negative battery terminal.

Order of Installation

- a. Interior preparation - remove panels
- b. Install Front Footwell light - Passenger's side
- c. Install Front Footwell light - Driver's side
- d. Install Vehicle Interface Harness
- e. Install ECU
- f. Reinstall Panels
- g. System check

INSTALLATION INSTRUCTIONS - Interior Accent Lighting Kit

INSTALLATION OVERVIEW

REMOVAL SEQUENCE

1. Inner Kicking Front Plate, FR LH
2. Dash Side finsher, LH
3. Instrument Lower Cover, LH
4. Instrument Lower Cover, RH

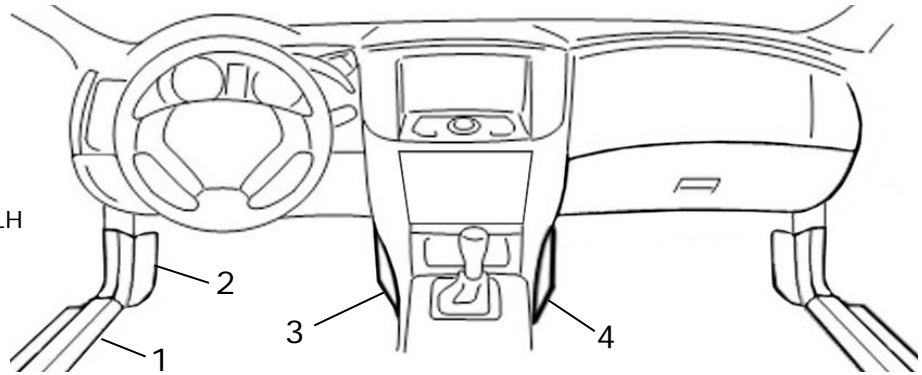

Passenger Side Footwell



Driver Side Footwell

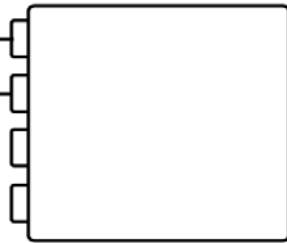

To Passenger Side Vehicle Accessory Connectors

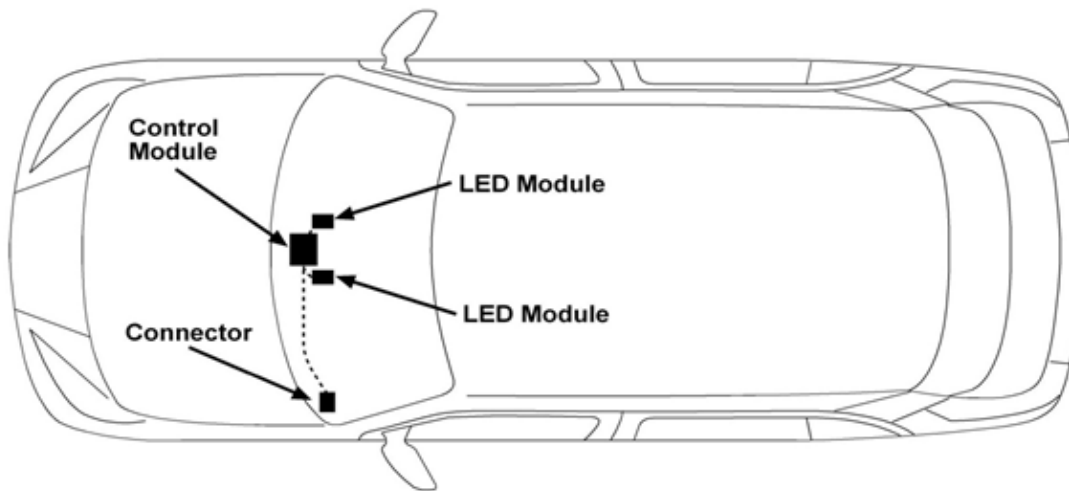

CRITICAL STEPS

The following steps are critical and must be performed **EXACTLY** as specified to ensure proper installation:

- Location of the lights must be followed exactly as described in this instruction.
- Posi-Tap™ instructions must be specifically followed as described.

INSTALLATION INSTRUCTIONS - Interior Accent Lighting Kit

INTERIOR PREPARATION:

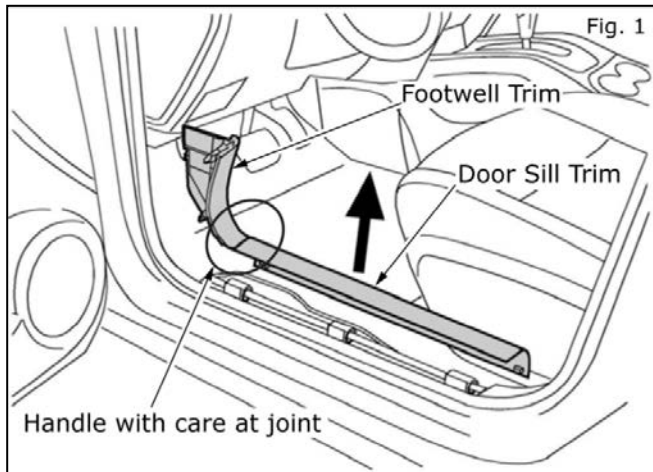

- 1) Remove Inner Kicking Plate and Dash Side Finisher
 - a) Move Driver seat to full rearward position. Using Nylon Trim stick, remove the trim panels: inner kicking front plate, FR LH & Dash Side finisher, LH together by pulling vertically on the Driver side, as shown in Fig. 1.

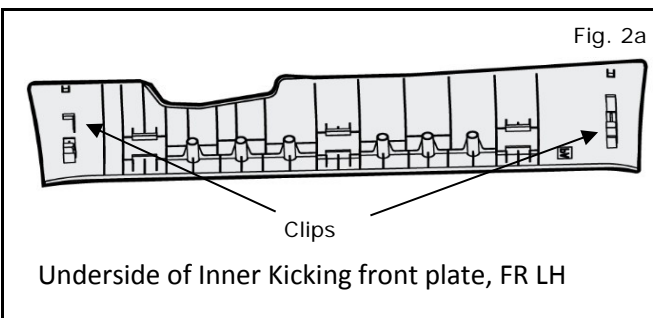

- 2) Clip Locations & Trim Removal
 - a) Clips are located at the locations shown in Figs. 2a & 2b. Note clip locations to avoid damage.
 - b) Using Trim tool, starting on the rear side of Inner Kicking plate, loosen clips along the panel.

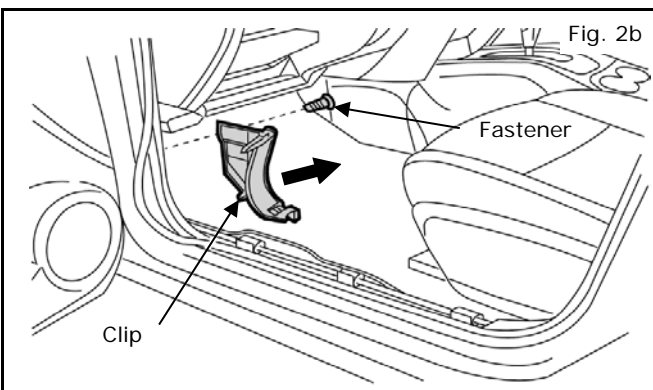

- c) Remove one fastener from dash side finisher, RH, by hand. Using Nylon Trim stick, carefully pry off trim panel pulling part horizontally towards center of vehicle, as shown in Fig. 2b. Note Clip locations to avoid damage.

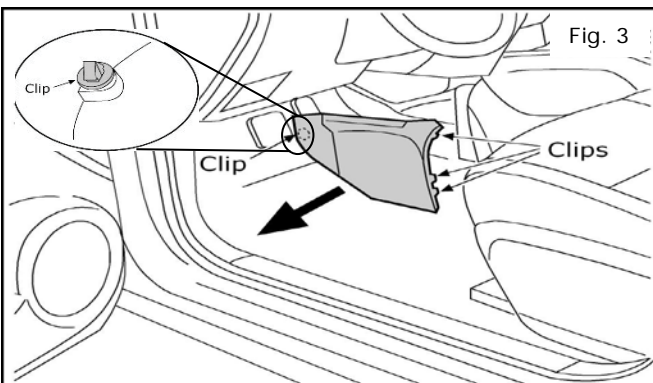

- 3) Carefully pry out Instrument Lower Cover, LH from driver side of center stack by hand, in direction shown.

INSTALLATION INSTRUCTIONS - Interior Accent Lighting Kit

INTERIOR PREPARATION:

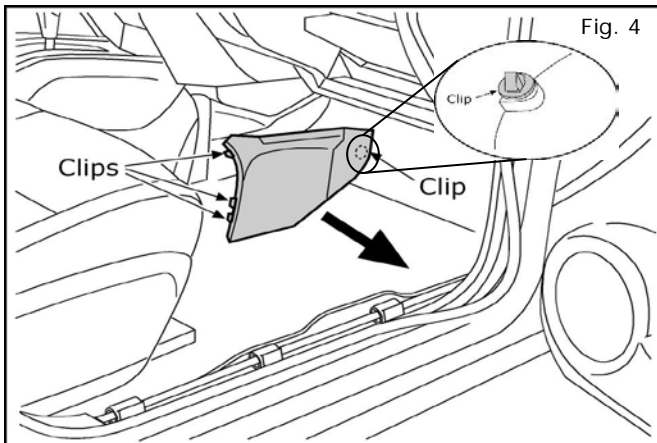

- 4) Carefully pry out Instrument Lower Cover, RH from passenger side of center stack by hand as shown.

NOTE:

Be careful not to damage any clips during removal of RH & LH panels/covers. Be sure the front retainer clip stays with the panel during removal. If clip does not come off with the panel, then remove with a pry tool and re-insert into panel.

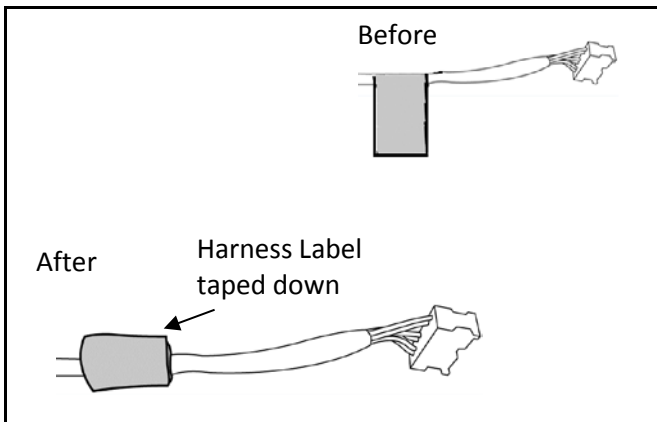

- 5) Secure down Harness Labels
 - a) To prevent any squeak and rattle, wrap all labels (on accessory and on harness) around and tape down.

INSTALLATION

PASSENGER SIDE LED MODULE INSTALLATION

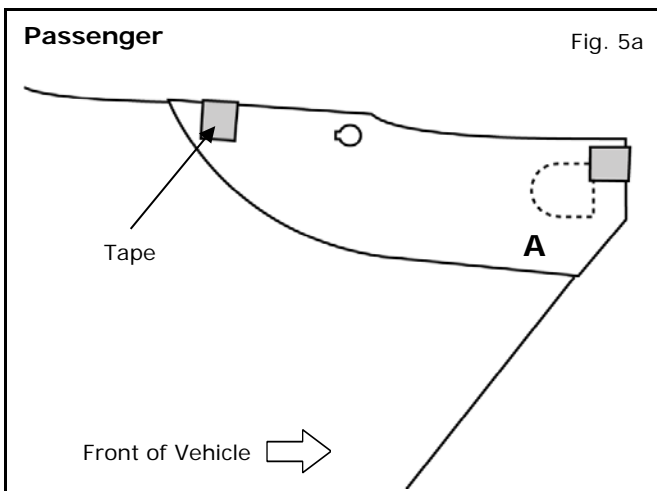

- 6) a) Place passenger side Instrument Lower cover on protected work surface. Trim out Passenger side Front Footwell Light template and tape into place outside panel as shown in Fig 5a.

INSTALLATION INSTRUCTIONS - Interior Accent Lighting Kit

INSTALLATION:

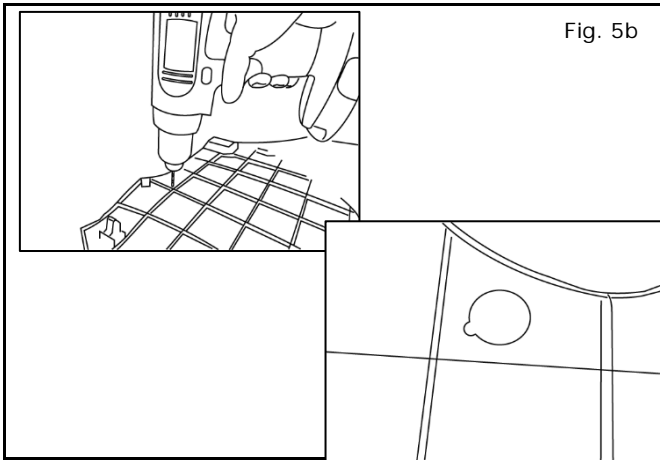

- b) Drill two pilot holes using 1/8" drill bit from outside of Instrument Lower cover to inside on two locations marked on template.
- c) Drill 5 mm (7/32") hole using lower pilot hole and 19 mm (3/4") hole using upper pilot hole as shown in template, from inside to outside (Fig. 5b).
- d) Remove the template. Clean any flashing from the hole. The final hole should look like as shown in bottom right figure in Fig. 5b.

NOTE: Make sure not to drill into any of the ribs on the inner side of Instrument Lower Cover.

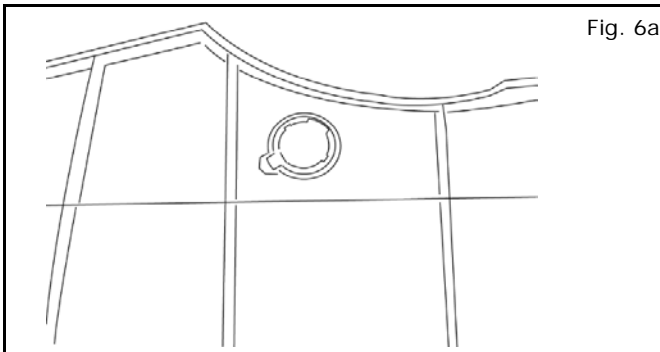

- 7) a) Place Bezel as shown in Fig. 6a.

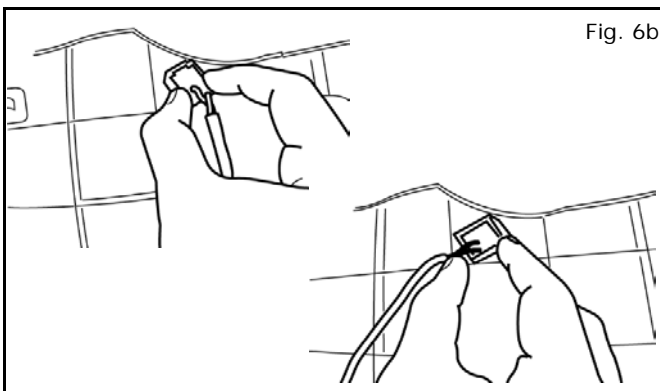

- b) Install light from inside into the bezel with harness & LED pointing to passenger side and turn down 1/4 turn clockwise to lock light into bezel (Fig. 6b).

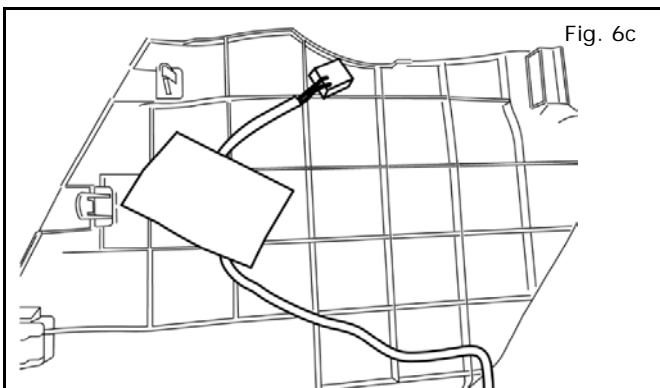

- c) Foam tape harness on the inside of the panel using 60x90mm Foam tape (Fig. 6c).

INSTALLATION INSTRUCTIONS - Interior Accent Lighting Kit

INSTALLATION:

DRIVER SIDE LED MODULE INSTALLATION

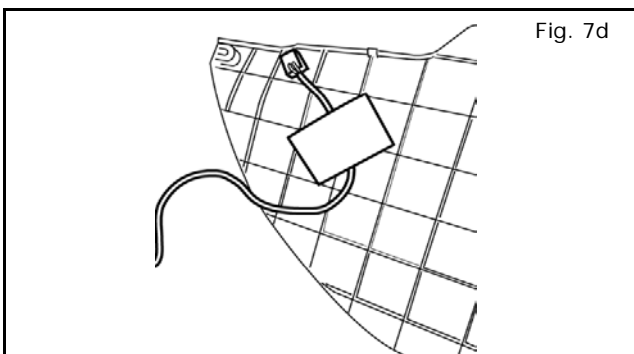
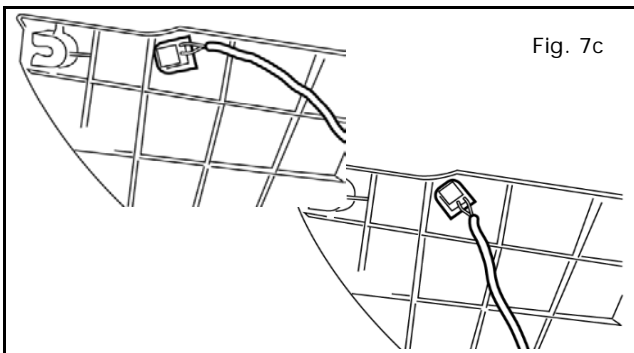
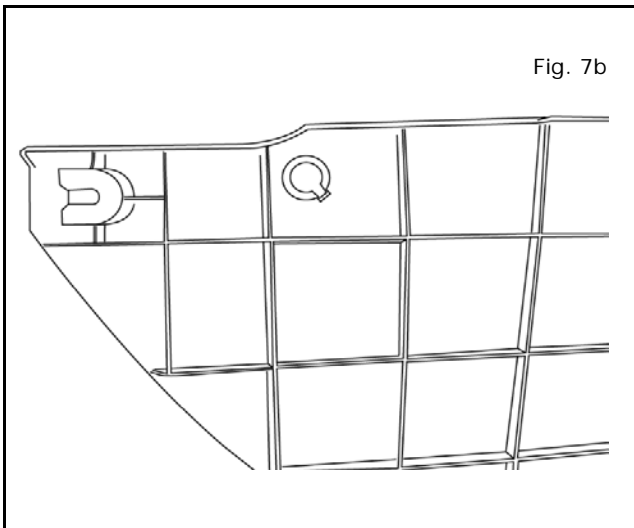
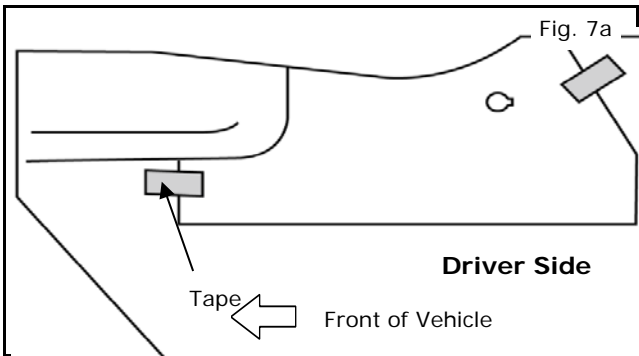

8) a) Place Driver Instrument Lower cover on a protected work surface. Trim out Driver side Front Footwell Light template and tape into place outside the panel as shown in Fig 7a.

b) Drill two pilot holes using 1/8" drill bit from outside of Instrument Lower cover to inside on two locations marked on template (similar to Passenger side installation).

c) Drill 5 mm (3/16") hole using lower pilot hole and 19 mm (3/4") hole using upper pilot hole as shown in template. (similar to Passenger side installation).

d) Remove the template. Clean any flashing from the hole.

e) Place the Bezel as shown in Fig. 7b.

NOTE: Make sure not to drill into any of the ribs on the inner side of Instrument Lower Cover.

f) Install light from inside into the bezel with harness & LED pointing to driver side and turn down 1/4 turn clockwise to lock light into bezel (Fig. 7c).

g) Foam tape harness on the inside of the panel using 60x90mm Foam tape (Fig. 7d).

INSTALLATION PROCEDURE: POSI-TAP

- 9) Locate driver side Accessory Connector plug behind the access panel on outer edge of dash. Pull the plug free from tape.

NOTE: A previously installed accessory may be present. If so, carefully remove accessory connector harness from accessory connector plug before posi-tapping. It is recommended that all posi-tapping be completed before reattaching accessory connector harness to the plug.

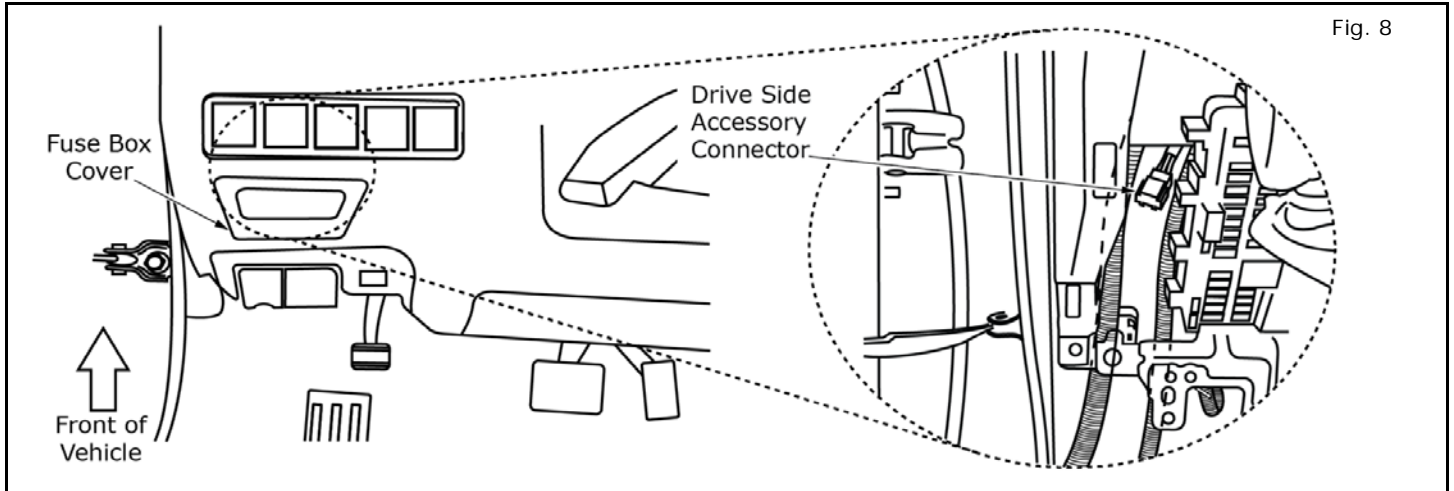

Fig. 8

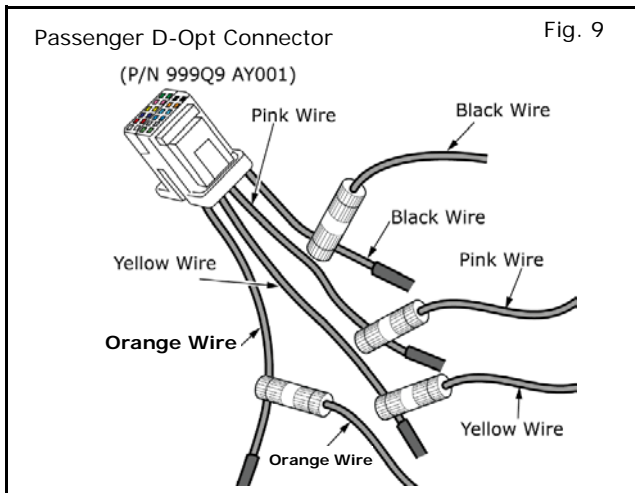

Fig. 9

- 10) Connect lighting power harness to accessory connector harness using posi-taps.
- Connect **BLACK** wire from power harness to **BLACK (GND)** wire on accessory connector harness.
 - Connect **ORANGE** wire from power harness to **ORANGE (ACC)** wire on accessory connector harness.
 - Connect **PINK** wire from power harness to **PINK (BATT_SAVER)** wire on accessory connector harness.
 - Connect **YELLOW** wire from power harness to **YELLOW (ROOM_LAMP)** wire on accessory connector harness.

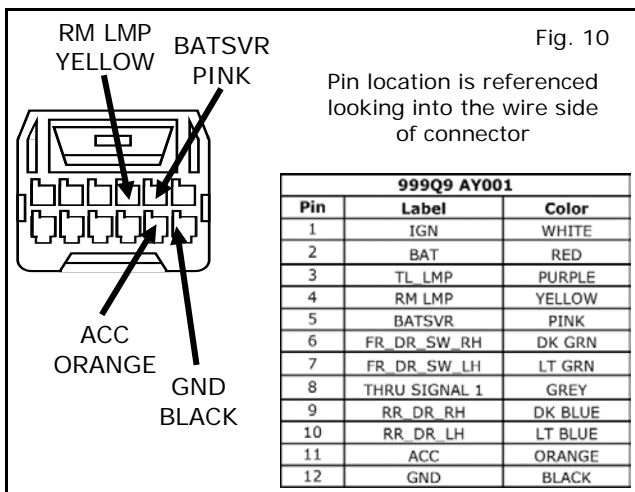

Fig. 10

- 11) Accessory service connector pin out reference is shown. P/N 999Q9 AY001

NOTE:

- A previously installed accessory may be present. If so, carefully remove accessory connector harness from accessory connector plug before posi-tapping.
- It is recommended that all posi-tapping be completed before reattaching accessory connector harness to plug.
- If there is not a previously installed accessory, remove dummy plug in connector. See detail.
- Wrap harness side of connector in foam tape as to allow accessory connector to be connected and disconnected.

INSTALLATION PROCEDURE: POSI-TAP

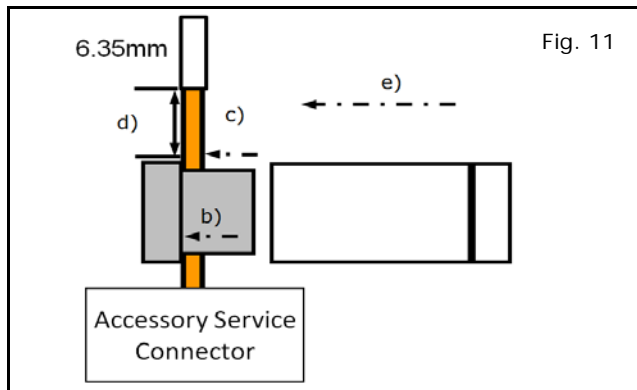

- 12) Posi-tapping an Accessory service wire (Fig. 11)
 - a) Identify and confirm correct wire in the Accessory Service Connector to be tapped.
 - b) Remove cap (slot side) from tap body.
 - c) Slide cap around single accessory wire.
 - d) Position cap $\geq 6.35\text{mm}$ (0.25in) away from the heat shrink end of Accessory Service Connector (measurement for first posi-tap installed on the circuit).
 - e) Tighten the tap **TIGHT** with finger pressure.
 - f) Tighten by another quarter turn.

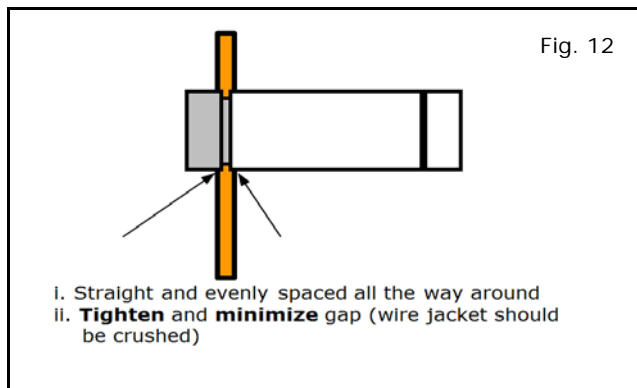

- 13) Inspecting the tap for correct installation (Fig. 12).
 - a) Pull on the wire lightly to ensure connection.
 - b) Inspect the tap to ensure correct installation.
 - c) Test the signal to ensure that it is working

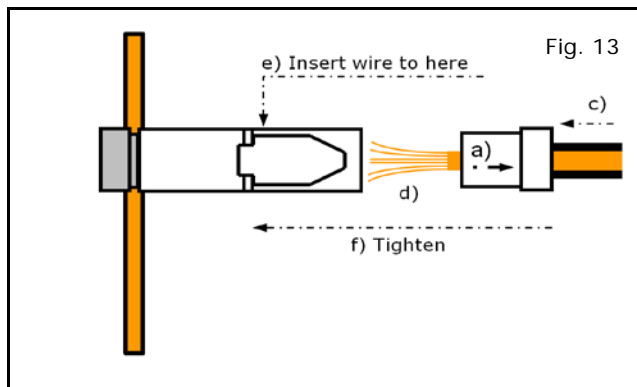

- 14) Tap accessory wire (Fig. 13).
 - a) Remove tap (non-pierce) side from tap.
 - b) Remove the protective stub from the wire.
 - c) Insert wire through the non-pierce side opening.
 - d) Spread the individual strands into fan shape.
 - e) Insert wire into the tap body and ensure that it is all the way in.
 - f) Tighten the tap **TIGHT** with finger pressure.
 - g) Tighten by another quarter turn.

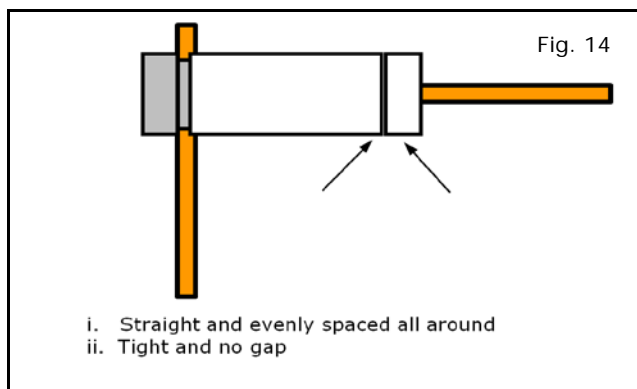

- 15) Confirm the tapped accessory wire.
 - a) Pull on the wire lightly to ensure connection.
 - b) Inspect the tap to ensure correct installation as shown in Fig. 14.

INSTALLATION PROCEDURE: POSI-TAP

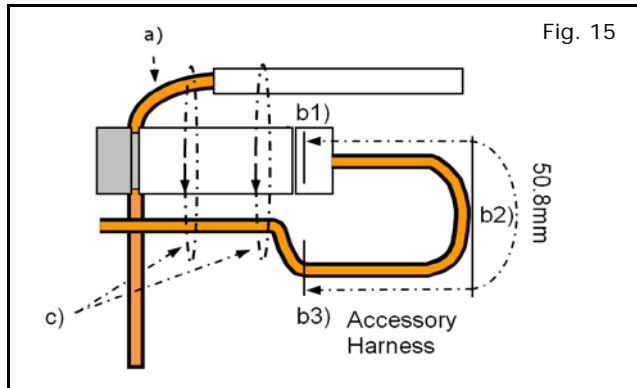

Fig. 15

- 16) Forming strain relief loop - required (Fig. 15).
 - a) Gently bend end of pierced wire (where it exits cap) down towards body of posi-tap.
 - b) On tapped side wire; starting at point b1), measure 50mm to point b3). Make first bend of loop b2), half measured distance - 25mm, and up toward body of posi-tap, make second bend of loop b3).
 - c) Secure pierced wire on heat shrink side and tapped wire to body of tap with electrical tape (≥ 2 revolutions).

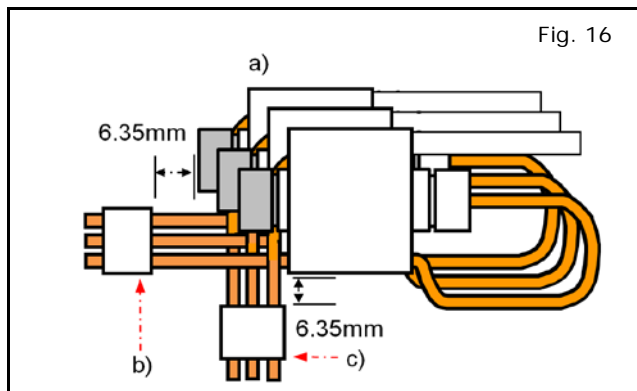

Fig. 16

- 17) Securing multiple accessory taps (Fig. 16).
 - a) Tapped accessories (wires already secured to tap bodies) are stacked in a stagger on top of each other as shown in Fig a).
 - b) Secure tapped wires on connector side of posi-taps to each other with electrical tape (≥ 2 revolutions) at a distance of ≥ 6.35 mm as shown in Fig b).
 - c) Pierced wires of posi-taps are secured to each other with electrical tape (≥ 2 revolutions) at a distance of ≥ 6.35 mm (0.25in) as shown in Fig c).

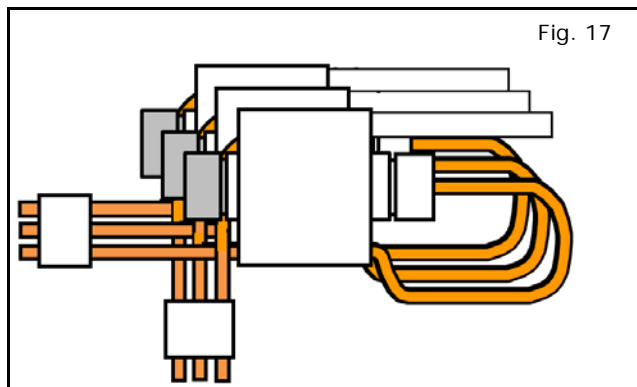

Fig. 17

- 18) Securing multiple accessory taps (Fig. 17).
 - a) Make sure the accessory taps have been wrapped appropriately as detailed previously and as shown.

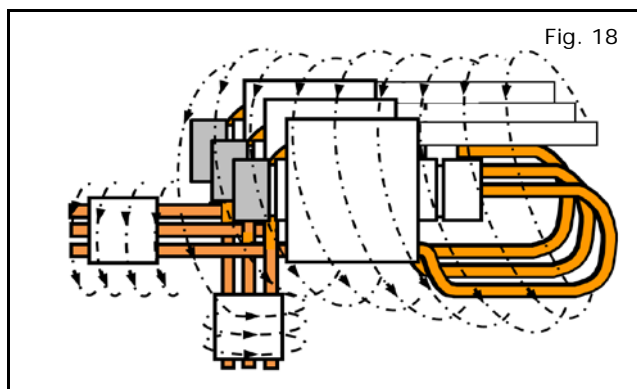
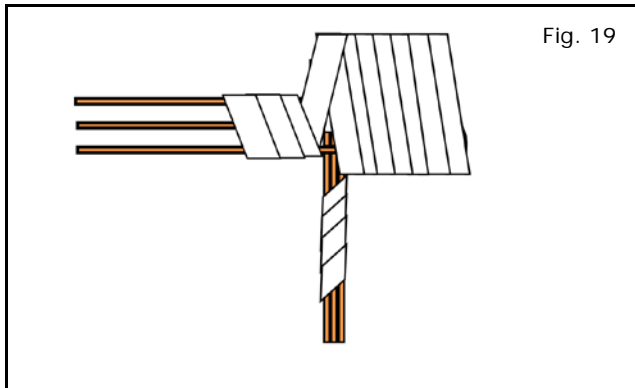

Fig. 18

- 19) Securing multiple accessory taps.
 - a) Starting at heat shrink; firmly wrap posi-tap bundle with electrical tape or non-adhesive wire harness tape, making sure to overlap previous revolution.

Note: If using non adhesive tape secure at the of wrap with electrical tape ≥ 2 revolutions.

INSTALLATION PROCEDURE: POSI-TAP



- 20) Securing multiple accessory taps
a) Make sure the finished wrap looks similar to Fig. 19.

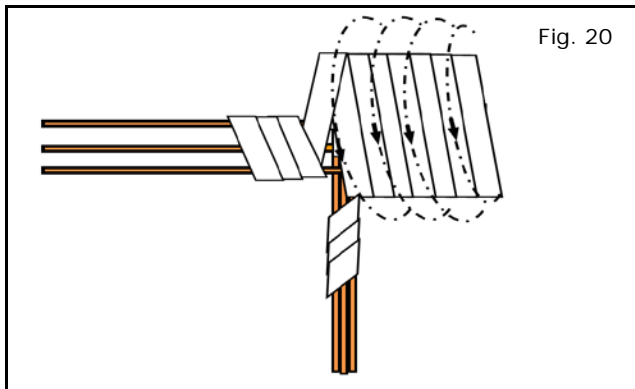

- 21) Foam wrap for posi-tap bundle (foam strips)
a) Wrap the posi-tap bundle with foam tape, following a pattern similar to the electrical tape, making the best use of foam strips provided.

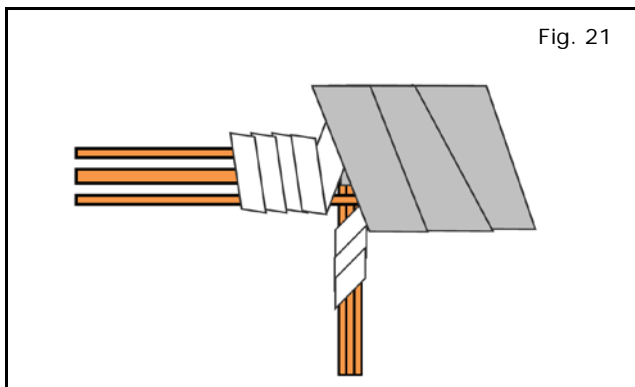

- 22) Finished foam wrap for bundle (strips-top view)
a) Make sure the finished wrap looks similar to Fig. 21.

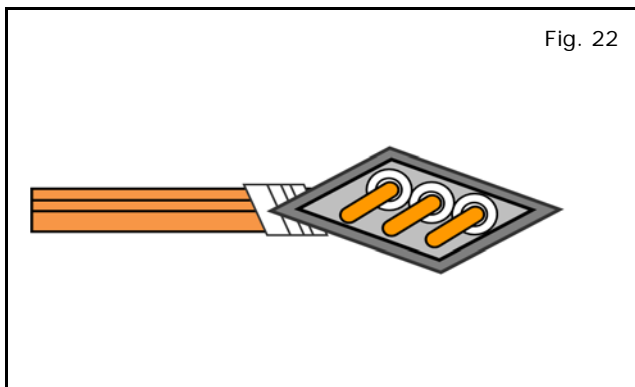

- 23) Finished foam wrap for bundle (strips-side view)
a) Make sure the finished wrap looks similar to what is shown in Fig. 22.

INSTALLATION INSTRUCTIONS - Interior Accent Lighting Kit

INSTALLATION

⚠ CAUTION

- If a vehicle wire is being used by another accessory and a posi-Tap is present, tap the accessory wire NOT the vehicle wire.

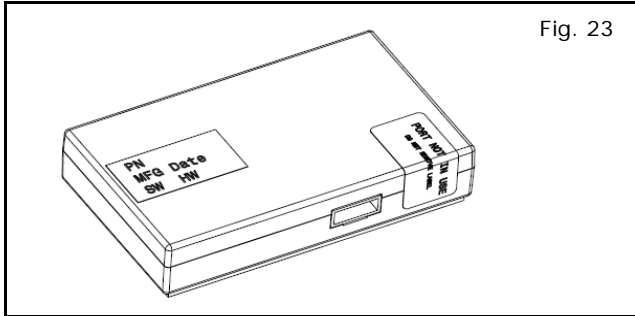

Fig. 23

24) ECU connection port identification (Fig. 23).

- a) Plug both footwell lamps into any 5 pin OUT ports.
- b) Plug power harness into 7 pin VEHICLE port.

NOTE: Step for reference only at this point

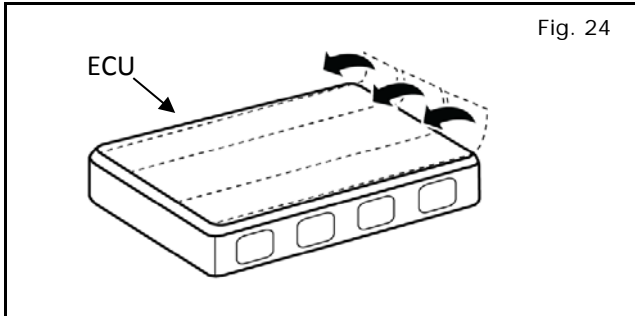

Fig. 24

25) Peel off all three backing papers from adhesive foam prior to placing the ECU on Carpet, as shown in Fig. 24.

NOTE: Step for reference only at this point

INSTALLATION INSTRUCTIONS - Interior Accent Lighting Kit

INSTALLATION

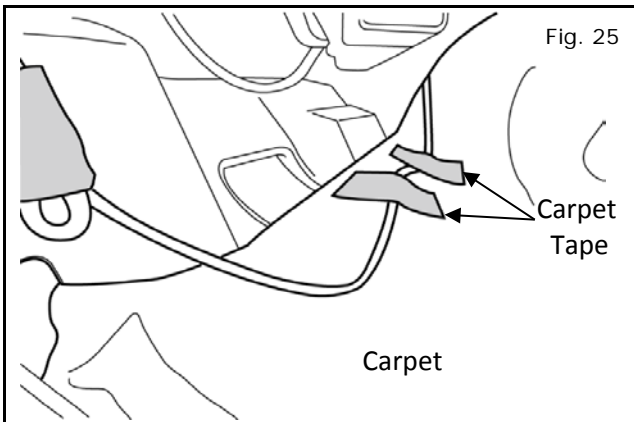

- 26) a) Feed the Power harness through the center stack (from ECU) to the Driver Side footwell.
- b) Route the Power harness under the carpet in the driver side footwell.
- c) Secure harness with two pieces of Carpet tape as shown in Fig. 25.

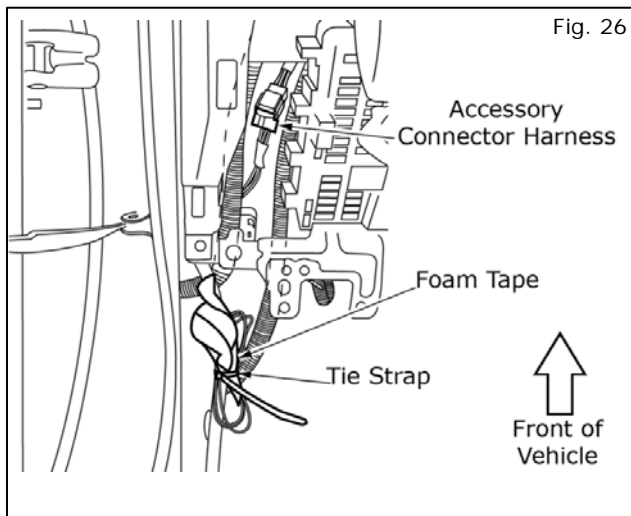

- 27) a) Plug Accessory Connector Harness into vehicle connector plug on the driver side.
- b) Loop excess wire harness length and protect loop with piece of foam tape, secure loop with 8" wire tie to tie harness bundle.
- c) Reinstall the cover panel.

NOTE:

Review Posi-Tap finishing steps on pages 10 -13 to secure wire bundle.

HARNES NOT INCLUDED IN KIT.

REFERENCE PART NUMBER 999Q9 AY001.

- 28) a) Position driver side Instrument Lower cover with LED mounted and harness foam taped.
- b) Route Driver LED Harness through center stack to Passenger side footwell.
- c) Carefully reinstall Instrument Lower Cover.

NOTE: Be careful not to damage any clips on the panel during reinstallation.

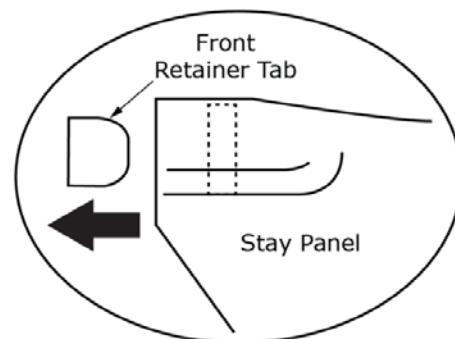
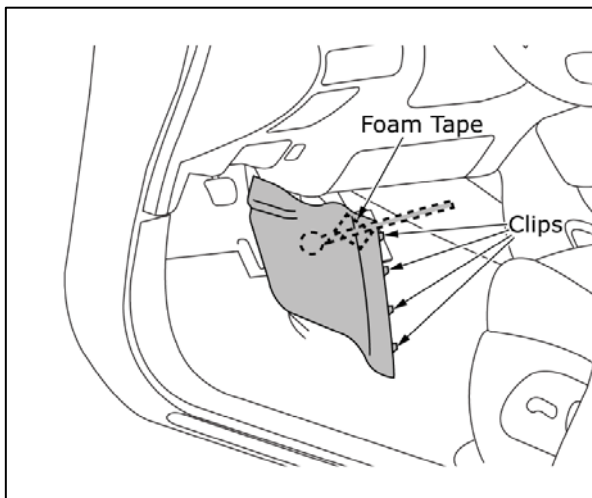
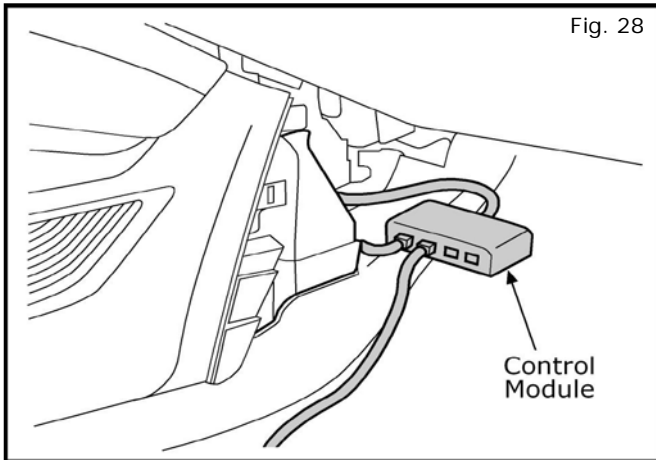

Fig. 27

INSTALLATION INSTRUCTIONS - Interior Accent Lighting Kit

INSTALLATION:



- 29) a) Position the Control Module near the center stack.
- b) Position the Passenger Side Instrument Lower cover near the center stack.
- c) Plug all harnesses into the control module as stated in Step 23.

NOTE:

Be sure to connect all harness plugs to the control module BEFORE final mounting.

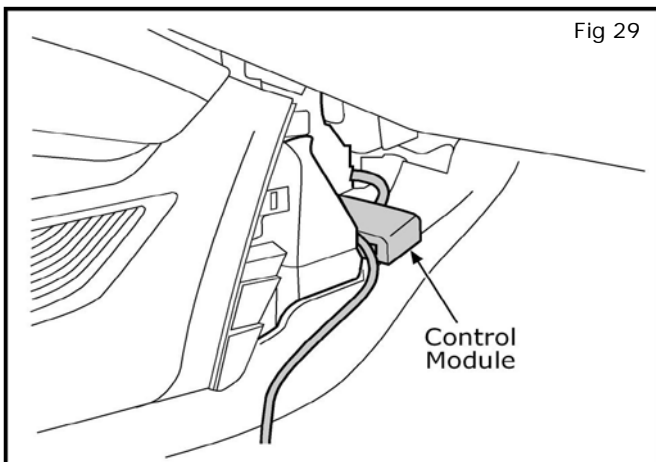

- 30) a) Peel the cover off the tape on the controller, as shown in Fig. 24.
- b) Securely place the controller on the carpet under the center stack as shown in Fig. 29. Apply even **15 lbs pressure for 20 seconds** on top of ECU.

NOTE:

Avoid placing the control module directly under the HVAC. Condensation could cause moisture to drip on electrical connections.

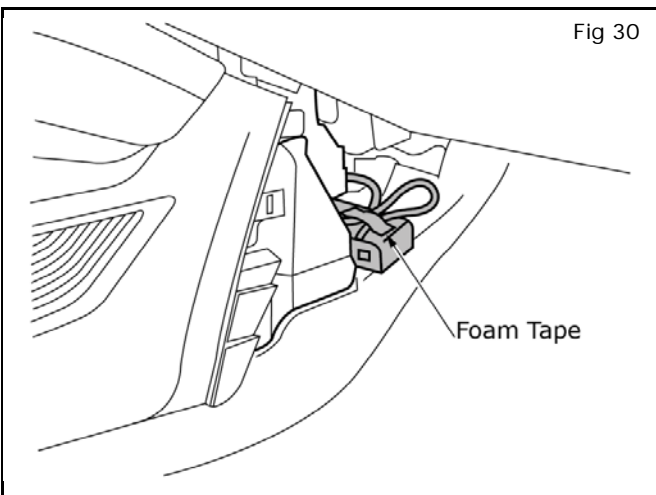

- 31) a) Position the passenger side Instrument Lower cover with LED mounted.
- b) Secure LED harness using 8" wire tie on top of module with foam tape so excess LED harness will not show under Instrument Lower Cover.
- c) Bundle any excess wiring, tie using 8" wire tie and secure with foam tape under the center stack.
- d) Secure the wiring from the module to the underside of the vent ducting with Carpet tape.

NOTE:

Be sure cables do not touch foot well panel, to prevent rattling.

NOTE:

Using scissors, Cut 60 x 90mm foam tape into two 60 x 45mm foam tapes, if required.

INSTALLATION INSTRUCTIONS - Interior Accent Lighting Kit

INSTALLATION:

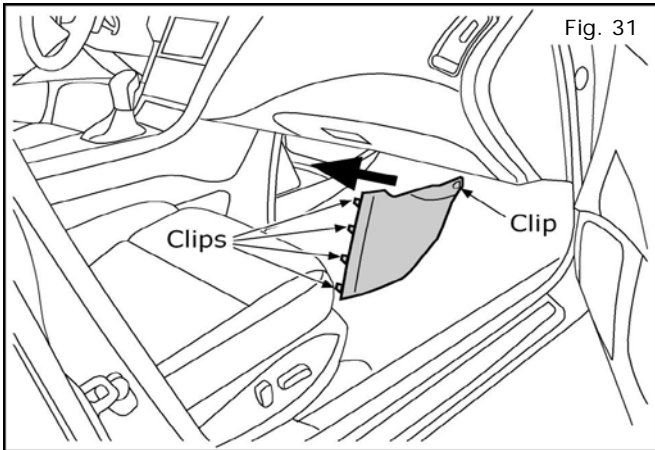

- 32) Carefully reinstall the side stay cover with LED mounted on the passenger side of the center stack.

NOTE:

Be careful not to damage any clips on the panel.

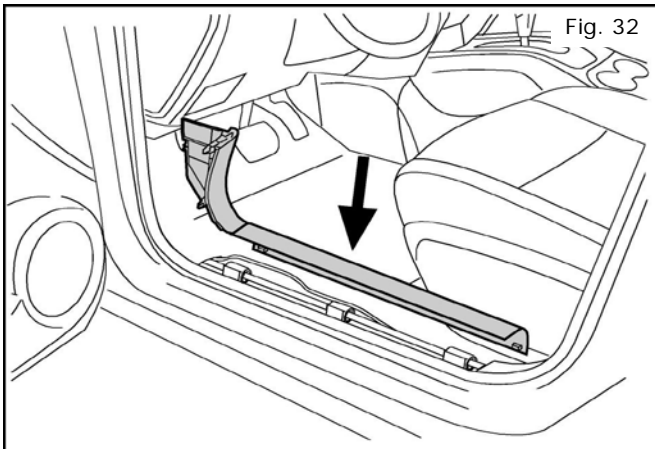

- 33) Reinstall the outer footwell trim panel on the driver side of the vehicle.

NOTE:

Be careful not to damage the clips on the inside of the panel.

NOTE:

Trim all cable ties. Check installation. □

ACCESSORY CHECK:

- Connect the battery negative terminal and tighten the nut to 5.4 N-m (47.8 lb-in)
- Check all **Critical Installation Steps**.
- Verify all wiring is secure and not exposed.
- Trim all excess cable ties flush.
- Turn ignition switch to "**ACC**" position.
- Confirm accessory main features and functions. Confirm foot well lamps illuminate. Diagnostic flow chart is available on the next page for troubleshooting. (For complex electrical accessory, a diagnostic flow chart is required.)
- Check all vehicle electrical systems that the accessory interfaces with.
 - Vehicle electrical system 1 (Must for pre-wiring, overlay harness, and Posi-Tap)
 - Vehicle electrical system 2 (Electrical system(s) where the accessory connects.)

RE-INSTALLATION OF REMOVED PARTS:

- Re-install all removed vehicle parts. Refer to the vehicle service manual as necessary.

CAUTION

- Use caution when re-installing interior components to avoid damage, scratches, or breaking of mounting clips. Refer to the vehicle service manual for more information.

FINAL INSPECTION:

- Verify re-installed trim parts for proper flush fit (no gap, no waviness, etc.).
- Verify all clips are fully engaged and locked.
- Verify re-installed trim parts are free from cracks, scratches or stress marks.
- Verify vehicle headliner, seat, steering wheel, center console, floor carpets, etc. are not soiled.
- Verify interior and exterior is not damaged.
- Turn ignition switch to "ON" and confirm proper operation of Vehicle Systems
 - If equipped, verify all window and sunroof one touch operation and perform the reset procedure if necessary. Refer to the vehicle service manual for more details.
 - Confirm proper audio function (AM, FM, SAT, CD and AUX).

FINAL INSPECTION:

- Start engine and verify that there are no new Diagnostic Trouble Code. Turn ignition switch to "**OFF**".
- Place the Owner Manual, Quick Reference Guide, and/or other Manual in the glove box.
- If this vehicle will be returned to a dealer lot or showroom for an extended period of time, be sure the extended storage switch is placed in the "inventory" position. Refer to the Extended Storage Switch verbiage at the beginning of the 'INSTALLATION PROCEDURE' section.
- Re-program radio presets and other vehicle settings to the recorded settings. No need to do this step if the extended storage switch is placed in the "inventory" position.

INSTALLATION INSTRUCTIONS - Interior Accent Lighting Kit

CHECK OUT

- (1) Shut all doors on the vehicle. □
- (2) Turn ignition switch to "ON" position.
- (3) Verify that both LEDS come on and that there is no dark cutoff area on the passenger side.
- (4) Check the trim for a proper, flush fit after re-installing the interior components.
- (5) Clean the interior of the vehicle.
- (6) Inspect the vehicle interior and exterior for damage.
- (7) Check and clear trouble codes (DTC).
- (8) If this vehicle will be returned to a dealer lot or showroom for an extended period of time, be sure the extended storage switch is placed in the "inventory" position. (Refer to section 9 - Vehicle Preparation).
- (9) If vehicle is NOT going into storage, reset the radio presets to the recorded settings.

Note: When diagnosing electrical system problems, first disconnect the accessory connectors and note effect on system. Continue the investigation with the accessory connectors disconnected. Remember to reconnect the accessories when the investigation is complete.

Posi-Tap™ is protected by patent # 5,228,875 5,695,369 5,868,589 6,692,313 Jap 2881414 Aus 708700 Tia 103534 Can 2204826 Mex 200626 Korea 477279 China Z197105562.9 & others pending.

INSTALLATION INSTRUCTIONS - Interior Accent Lighting Kit

BILL OF MATERIALS

Nissan Universal Accent Lighting Kit - 999F3 C5000

	Kit Contents	Qty
1	Accent Lighting Controller (Single Color - White)	1
2	LED Lamp Assembly (w/ Harness)	2
3	Power Harness	1
4	Hardware Kit	1
5	Wire Tie 8"	4
6	Foam Tape, 60 x 90mm	5
7	Posi Tap	4
8	Open Bezel	2
9	3M Beta/ Carpet Tape 5073, 48 x 89mm	3
10	Installation Instruction Replacement Template	1

INSTALLATION INSTRUCTIONS - Interior Accent Lighting Kit

MECHANIZATION

ACCY_SER_CONN

ACCENT LIGHTING KIT

DRIVER SIDE CONNECTOR

IGN	1
BAT	2
TAIL_LAMP	3
ROOM_LAMP	4
BAT_SAVER	5
FR_DOOR_SW_RH	6
FR_DOOR_SW_LH	7
THRU_SIGNAL_1	8
RR_DOOR_RH	9
RR_DOOR_LH	10
ACC	11
GND	12

YEL

PNK

ORG

BLK

TH12FW-NH

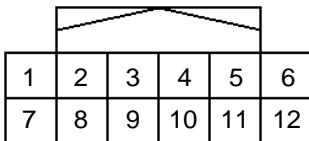

Note: Pin location is referenced looking into wire side of connector.

**LED MODULE -
DRVR SIDE**

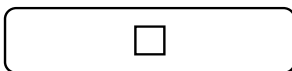
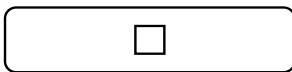

**LED MODULE -
PASS SIDE**

CONTROL
MODULE

ORANGE

PINK

YELLOW

BLK

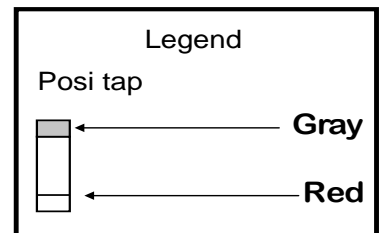

FOOTWELL LAMP HOLE LOCATION - DRIVER SIDE

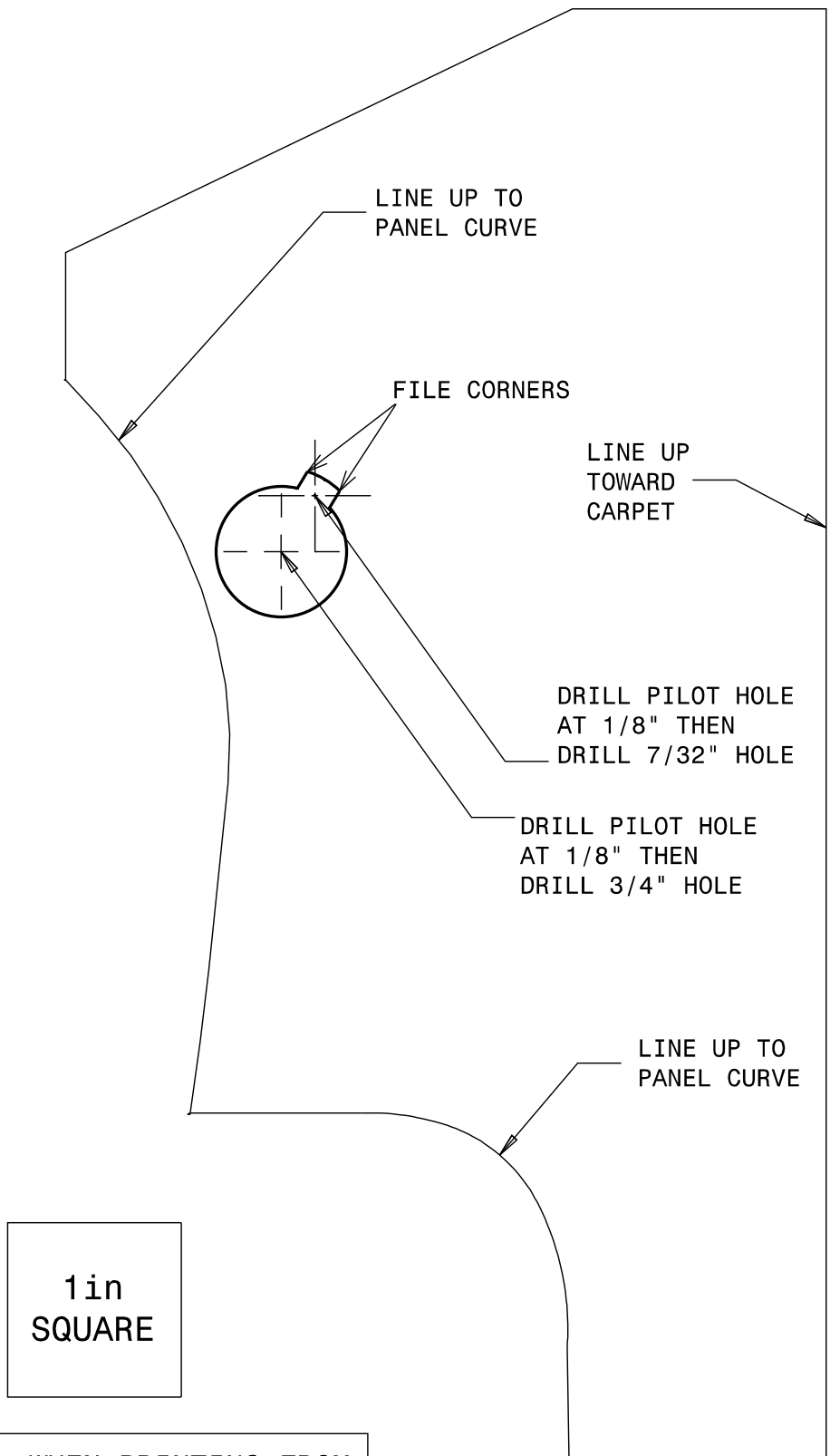

NOTE : WHEN PRINTING FROM
PDF SELECT ACTUAL SIZE

FOOTWELL LAMP HOLE LOCATION - PASSENGER SIDE

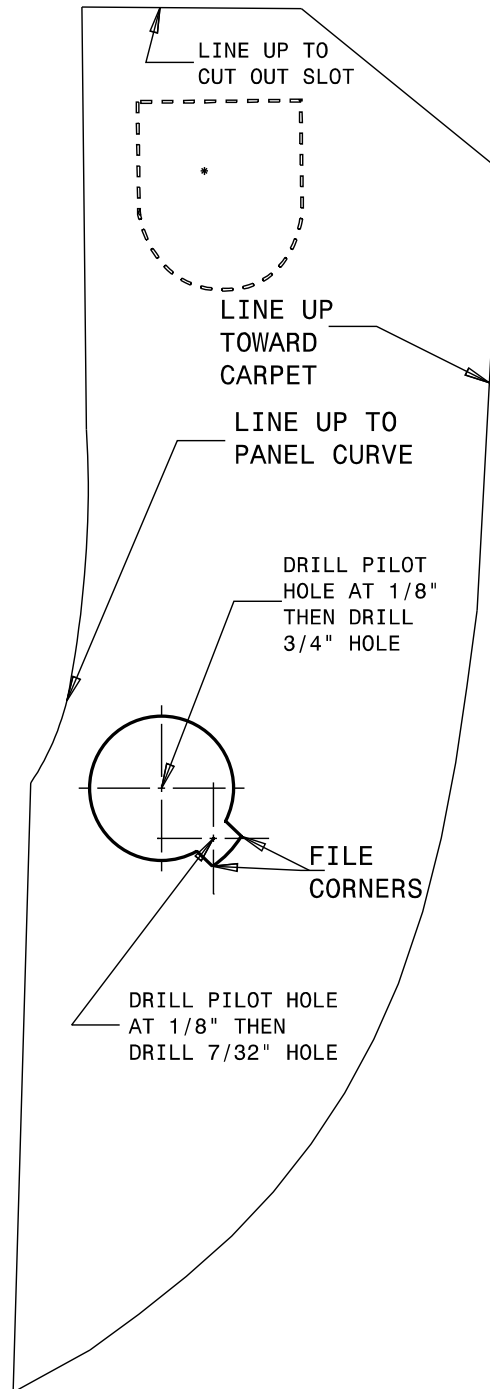

NOTE : WHEN PRINTING FROM
PDF SELECT ACTUAL SIZE

1in
SQUARE