



GENUINE PARTS

INSTALLATION INSTRUCTIONS

1. **DESCRIPTION:** Illuminated Kick Plate Kit
2. **APPLICATION:** Armada
3. **PART NUMBER:** T99G6 5ZW00, T99G6 5ZW30
4. **KIT CONTENTS:**

Item	QTY	Description	Service Part Number
A	1	Illuminated Front Kick Plate (RH)	Not Serviceable- Part of Kit T99G6 5ZWx0
B	1	Illuminated Front Kick Plate (LH)	
C	1	Non-illuminated Rear Kick Plate (RH)	
D	1	Non-illuminated Rear Kick Plate (LH)	
E	18	Cable Tie	
F	8	Foam Tape - black, 25 x 50 x 2 mm	
G	4	Foam Tape - black, 63 x 50 x 2 mm	
H	4	Posi-Tap Connector	
I	1	Installation Instruction Website Address	

ITEMS NOT IN KIT THAT MAY BE REQUIRED

J	2	Accessory Service Connector	999Q9 AY001
---	---	-----------------------------	-------------

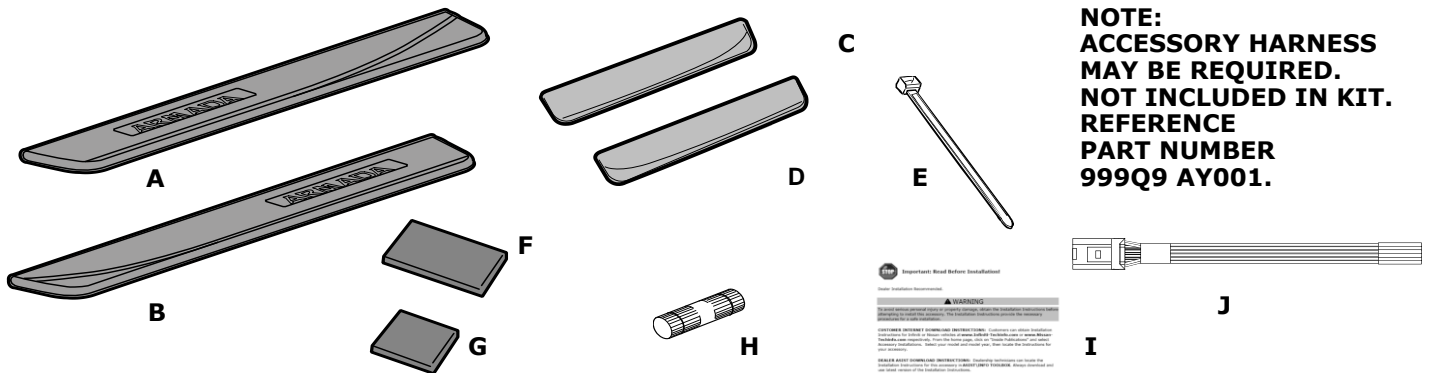

5. TOOLS REQUIRED

- Trim removal tool
- 50% Alcohol/50% Water solution
- Soft non-linting cloth
- Wrench, 10mm
- Screwdriver, straight 3/8"
- Wire Cutting Pliers
- Masking tape
- Electrical tape

6. PRE-INSTALLATION CAUTION/NOTES

- Dealer installation recommended. Instructions may refer to Service Manual
- Installation may require special tools
- This part is to be installed within a surface temperature range of 60-110°F

CAUTION

- This accessory must only be installed as specified in these instructions.
- Ensure at all times that parts are securely fitted and will not compromise the safe function of vehicle systems.

Vehicle Preparation:

⚠ CAUTION

• Always confirm the ignition is in the "OFF" position before changing the switch condition.

- 1) Apply parking brake
- 2) Confirm vehicle is not in the default shipping state or "Inventory position" as shown below. Failure to confirm vehicle has been removed from this state will result in loss of normal vehicle operation.
- 3) Locate Extended Storage Switch in cabin fuse block. Confirm it is in the "Customer" position. See below for reference.

a) To remove transit mode (Fuse Block):

1. Remove fuse cover lid.
2. Push down shorting pin.
3. Ign On 2 times without starting the vehicle.

b) To remove transit mode (BCM):

1. Confirm ignition switch is in "OFF" position.
2. Simultaneously push the signal and wiper switch fully down for two (2) seconds.

NOTE: While in BCM Transit Mode, turn signal indicators will remain illuminated for one minute.

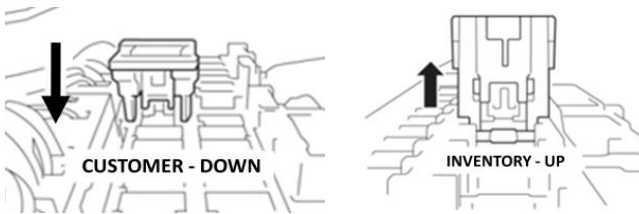
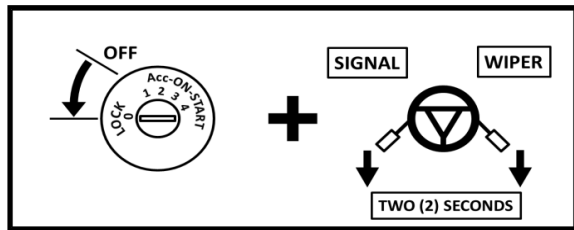
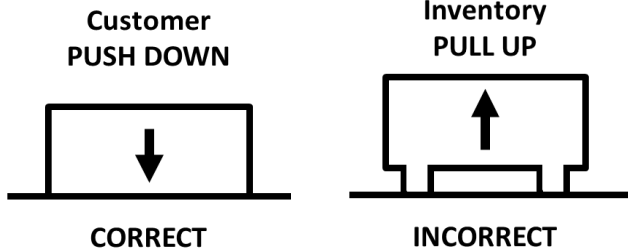

c) To return to transit mode for storage:

1. Ign Off.
2. Remove fuse cover lid.
3. Pull up shorting pin.
4. Assemble fuse cover lid.
5. Ign On 2 times without turn the vehicle on.
6. Confirm transit mode condition on meter

NOTE: Typical vehicle condition shown above. Switch is easily identifiable by the permanent, push-pull fuse holder. Actual position on the fuse block may vary, vehicle to vehicle.

Condition	Switch Position	Note
Vehicle is delivered to the dealer	Inventory Condition	
Technician performs PDI	Customer Delivery	Return to Inventory position after PDI.
Customer test drives the vehicle	Customer Delivery	Return to Inventory position after test drive.
Vehicle is being stored at the dealer	Inventory Condition	
Vehicle is delivered to customer	Customer Delivery	

NOTE: The Extended Storage Switch is only an aid to improve battery life during vehicle storage at the dealer. If the Extended Storage Switch fuse ever needs service after vehicle delivery, discard the Extended Storage Switch and install the correct fuse in its place.

- 4) Turn ignition switch to "ON" position
- 5) Record the customer radio presets and other presets as required.

Preset	1	2	3	4	5	6		

- 6) Put shift lever in "P" position for A/T and CVT or "1st" for M/T
- 7) Turn ignition switch to "OFF" position
- 8) Use seat and floor protection.

INSTALLATION INSTRUCTIONS - Illuminated Kick Plate Kit

7. INSTALLATION OVERVIEW

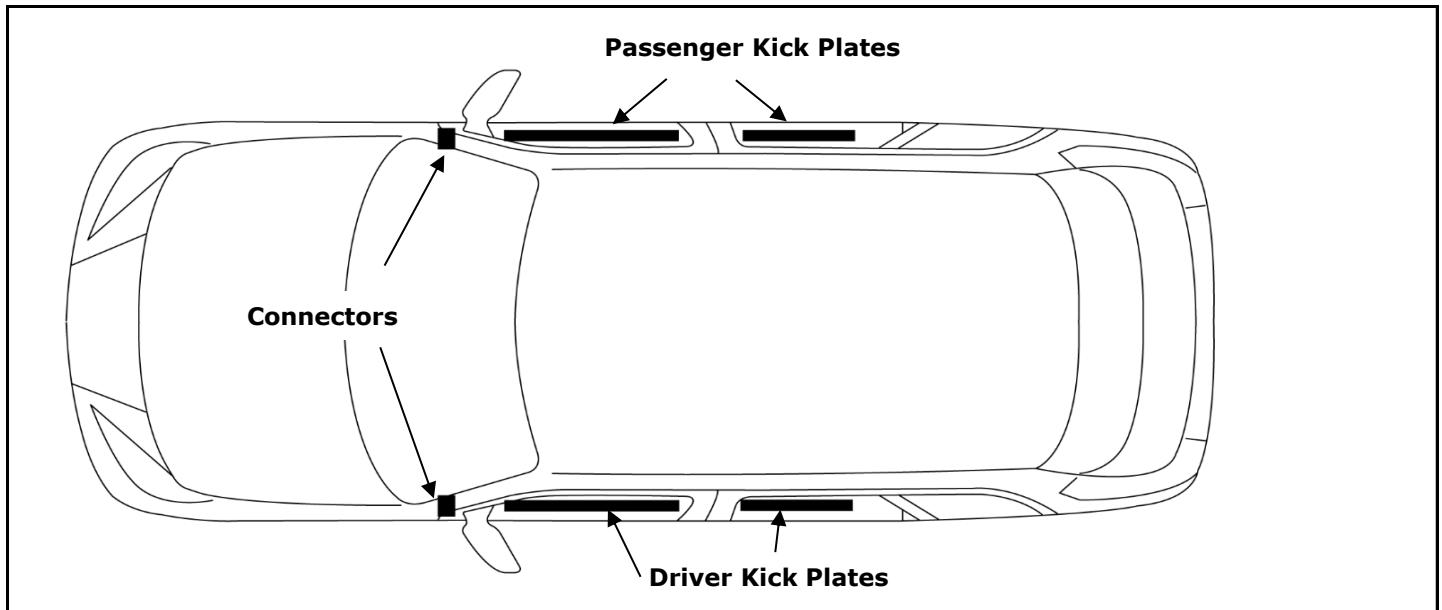
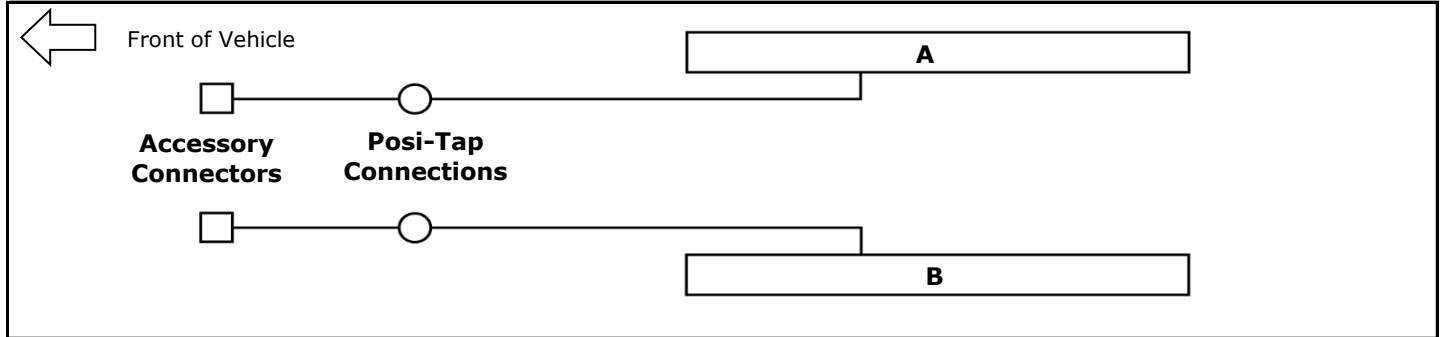

8. CRITICAL STEPS

The following steps are critical and must be performed **EXACTLY** as specified to ensure proper installation:

- Posi-Tap™ instructions must be specifically followed as described in Appendix A
- Be sure to apply masking tape as needed in order to protect any areas that may become scratched or damaged by tools.
- Be sure to apply foam tape to any wiring components that can be damaged over time by sharp edges.
- Test the functionality of the kit before final clean up and reinstallation of interior panels.

INSTALLATION INSTRUCTIONS - Illuminated Kick Plate Kit

7. INSTALLATION OVERVIEW

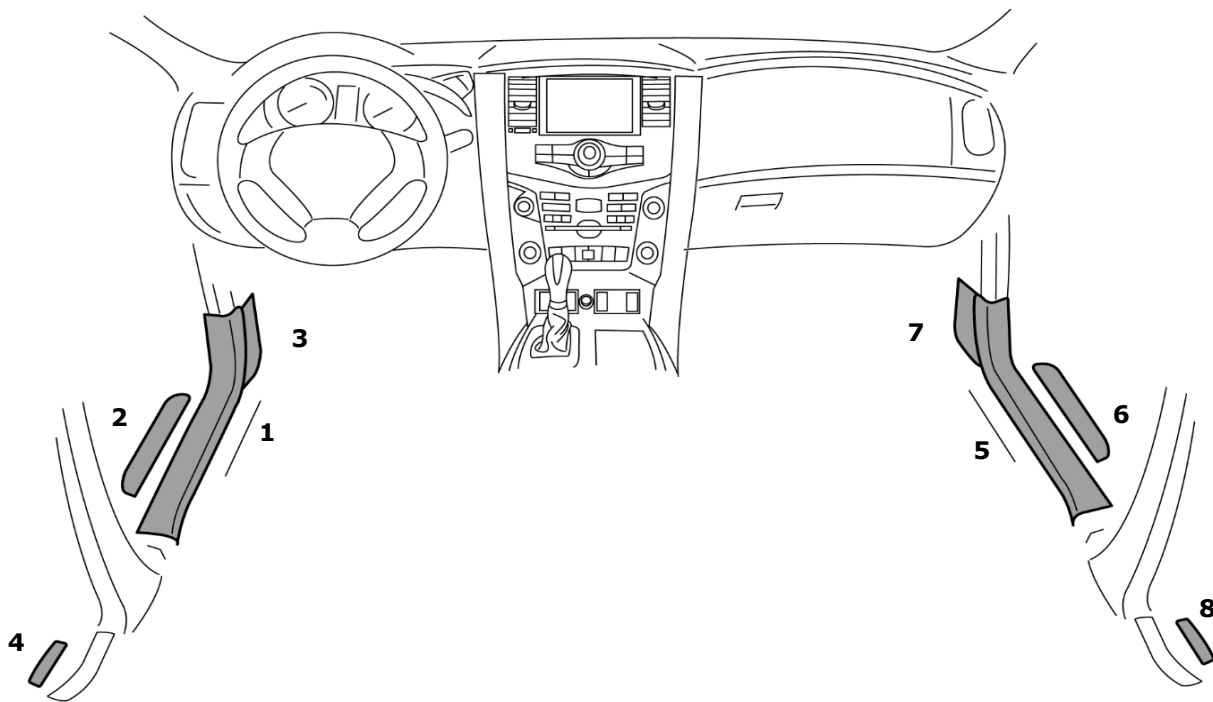

REMOVAL SEQUENCE

1. Front Kick Panel Inner, LH
2. Front Kick Panel Outer, LH
3. Dash Side Lower Panel LH
4. Rear Kick Plate Outer LH
5. Front Kick Panel Inner, RH
6. Front Kick Panel Outer, RH
7. Dash Side Lower Panel RH
8. Rear Kick Plate Outer RH

INSTALLATION INSTRUCTIONS - Illuminated Kick Plate Kit

12. INTERIOR PREPARATION

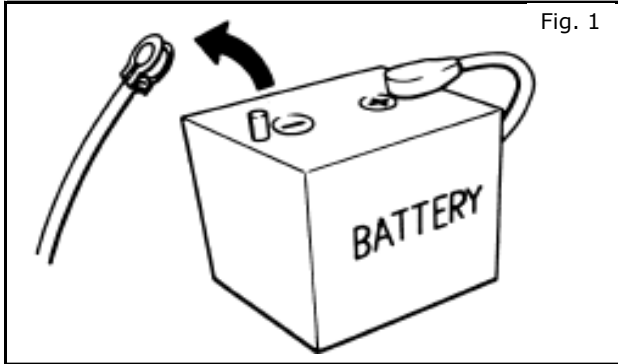

- 1) Disconnect negative battery terminal with a 10mm wrench.

⚠ CAUTION

CRITICAL STEPS TO DISCONNECT BATTERY:

- Allow 3 minutes after key off and doors closed for vehicle to time out (if doors are opened again additional time may be required). Disconnect negative terminal. Allow an additional 3 minutes after negative terminal disconnect before separating any electrical connectors.

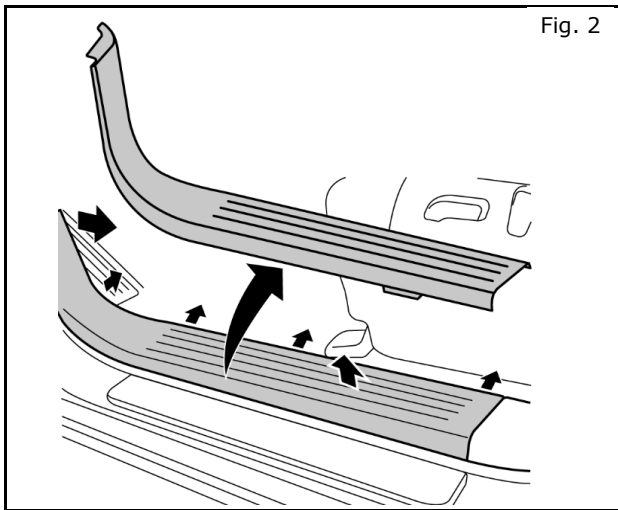

- 2) Carefully pry off inner door sill trim panel (LH) and remove from vehicle.

NOTE:

Be careful not to damage any mounting clips on the panel.

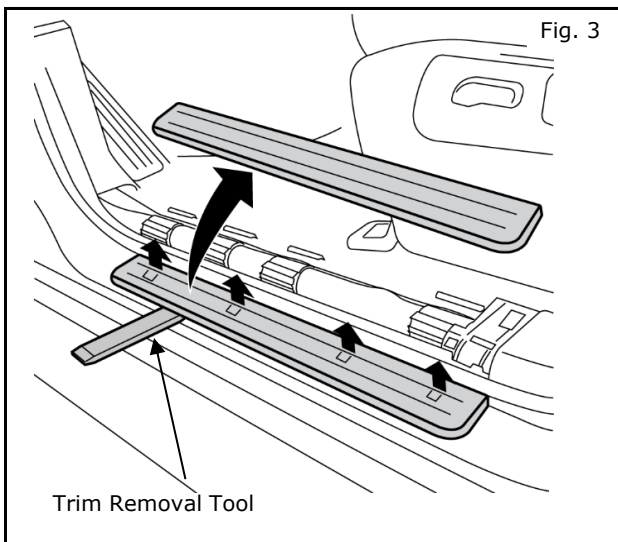

- 3) Carefully pry off door sill kick plate (LH) and remove from vehicle.

INSTALLATION INSTRUCTIONS - Illuminated Kick Plate Kit

12. INTERIOR PREPARATION

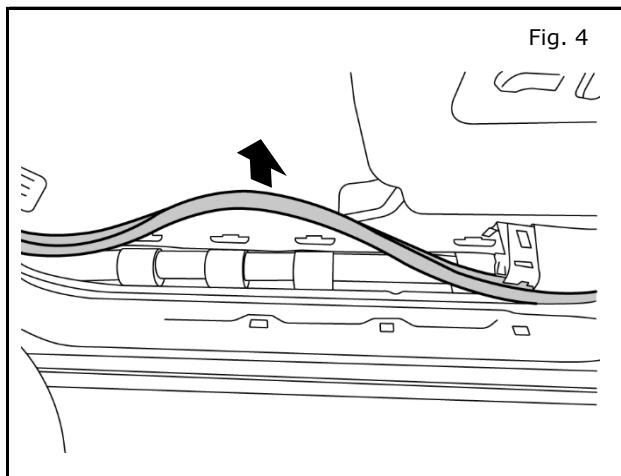

4) Carefully pull weatherstrip up at front door sill (LH).

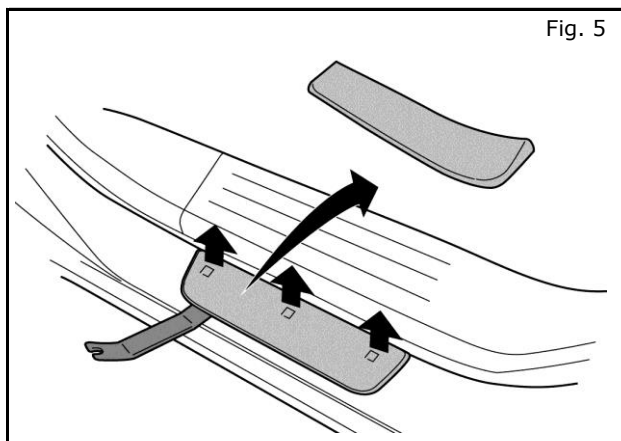

5) Carefully pry off rear door sill kick plate (LH) and remove from vehicle.

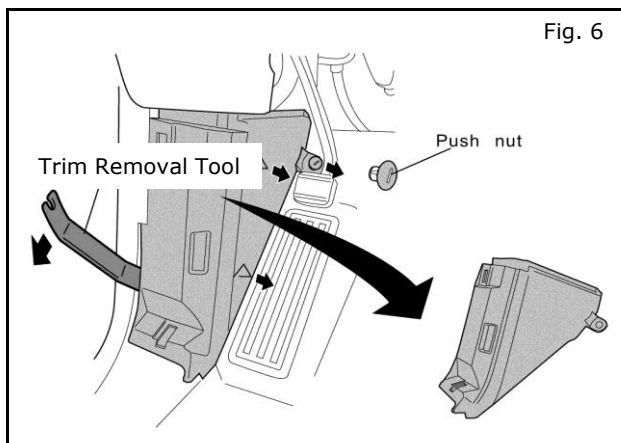

6) Remove Push Nut at top of outer foot well trim panel with a straight blade screwdriver. Carefully pry off panel and remove from vehicle.

INSTALLATION INSTRUCTIONS - Illuminated Kick Plate Kit

13. INSTALLATION

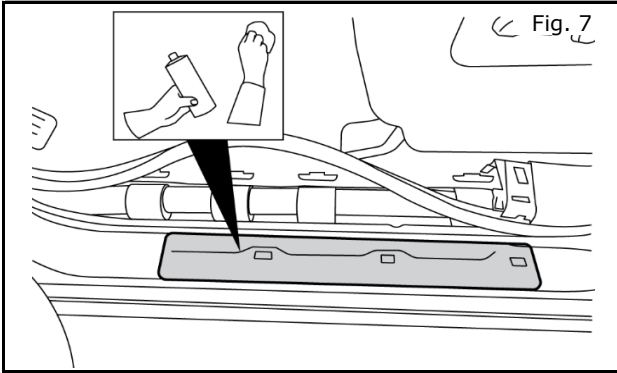

- 7) On driver side front door sill, clean area where new kick plate will be attached with alcohol solution. Let dry for 30 seconds.

NOTE:

If necessary, wipe the area clean of any dirt and grime before using alcohol.

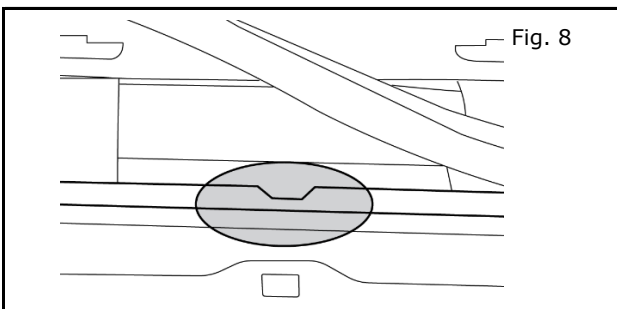

- 8) Clean attachment area on metal vehicle flange with alcohol solution. Let dry for 30 seconds.

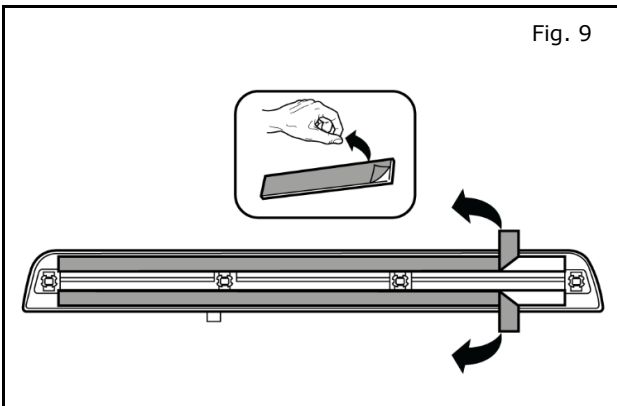

- 9) On back of kick plate, pull starter tabs to remove adhesive liners.

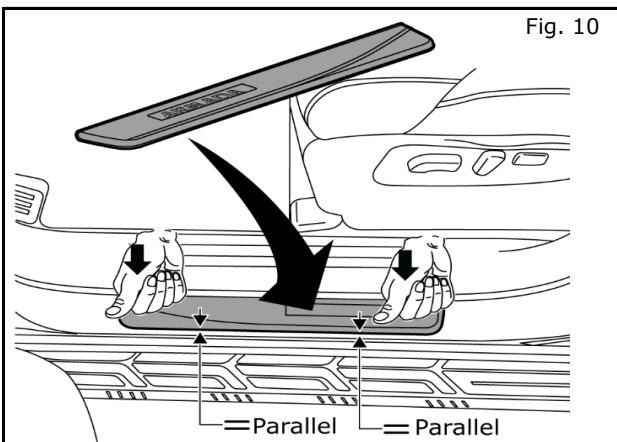

- 10) Align pins on new kick plate with holes on vehicle and position plate on vehicle. Be careful to keep outside edge parallel to rocker panel.
- 11) Apply minimum 15 lbs. of pressure for 30 seconds along kick plate to secure adhesive.

NOTE:

Use caution when applying pressure to the kick plate to avoid denting the part.

INSTALLATION INSTRUCTIONS - Illuminated Kick Plate Kit

13. INSTALLATION

Fig. 12

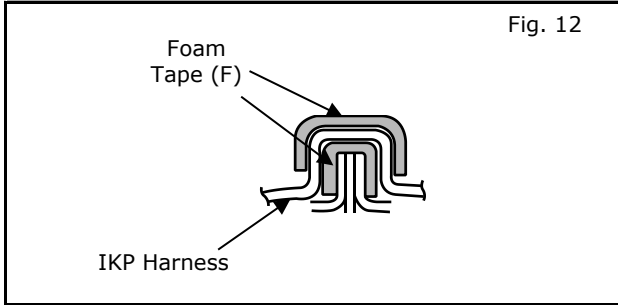

12) Route wire over flange.

- a) Attach one piece of (F) small foam tape (25 x 50 mm) to flange notch. Route harness over body flange/tape and apply second piece of tape (F) over top of harness.

Fig. 13

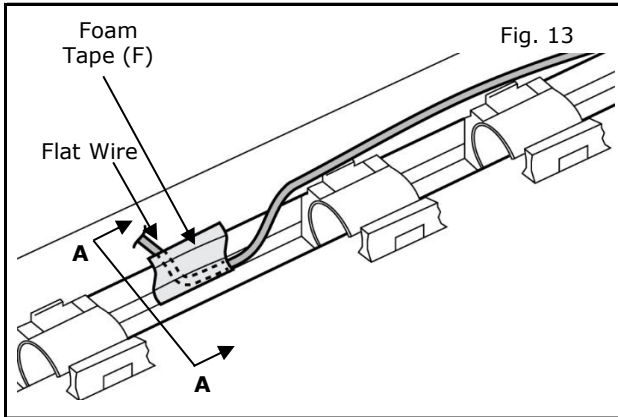

- b) Route harness toward front of vehicle along inboard side of flange as shown in figures 13 and 14.

Vehicle harness not shown in this view for clarity of IKP harness and tape position.

Attach one piece of (F) small foam tape (25 x 50 mm) to keep harness in place. See Fig. 14 Section A for cross section detail.

Fig. 14

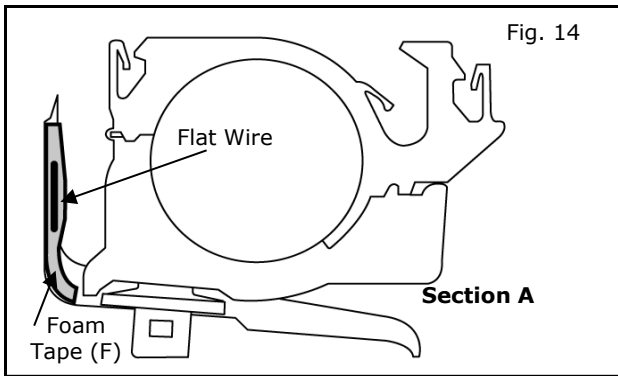
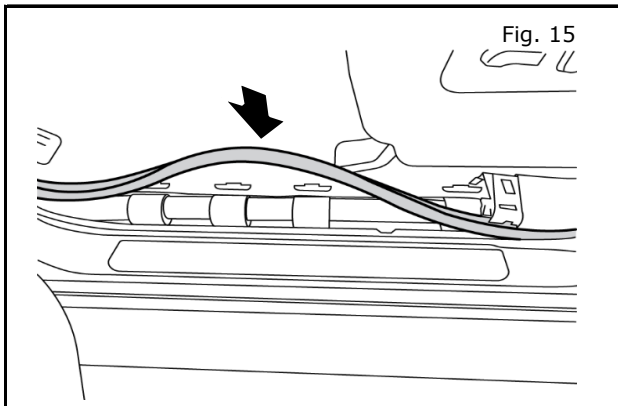

Fig. 15



13) Press the door sill weather-strip back down into position.

INSTALLATION INSTRUCTIONS - Illuminated Kick Plate Kit

15. INSTALLATION

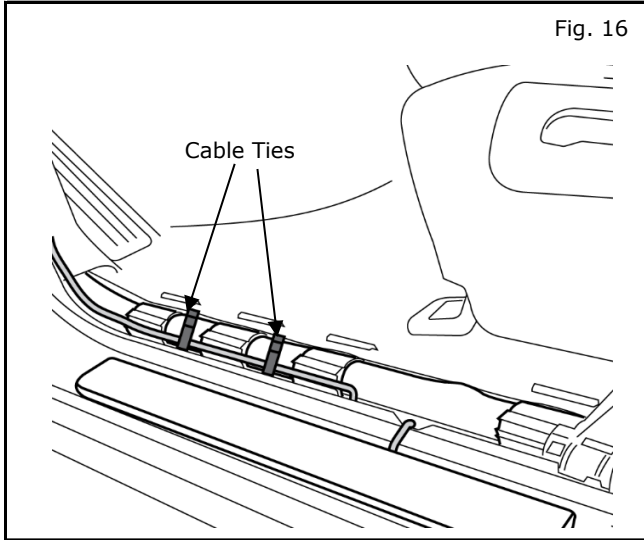

- 14) Route harness along existing vehicle harness and secure with 2 cable ties as shown. Route harness along outboard side of existing harness.

NOTE:

DO NOT secure the wiring to the drain or washer fluid tubing.

- 15) REPEAT STEPS 2 THROUGH 14 FOR Passenger SIDE OF VEHICLE.

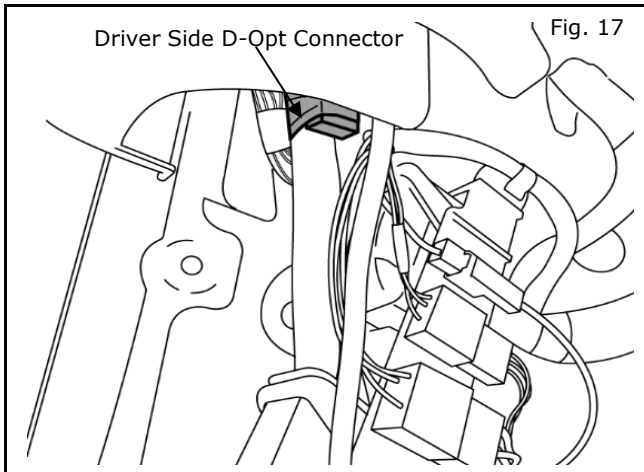

- 16) Locate driver side D-Opt Connector. It will be located up under dash in area shown near the A-pillar.

NOTE:

A previously installed accessory may be present. If so, carefully remove Accessory Service Connector from Accessory Pre-Wire Connector before posi-tapping. It is recommended that all posi-tapping be completed before reattaching Accessory Service Connector to Pre-Wire Connector.

INSTALLATION PROCEDURE: IKP WIRE INSTALLATION

CAUTION

This Accessory Service Connector is for use only with Genuine Nissan (or Infiniti) or Nissan (or Infiniti) approved accessories. Use of this connector with non Genuine Nissan (or Infiniti) or Nissan (or Infiniti) approved accessories or failure to follow the installation instructions for said connector being mentioned herein may result in damage to the accessory and/or your vehicle. Nissan (or Infiniti) is not liable for loss or damage due to improper installation or the installation of non Genuine or non approved accessories.

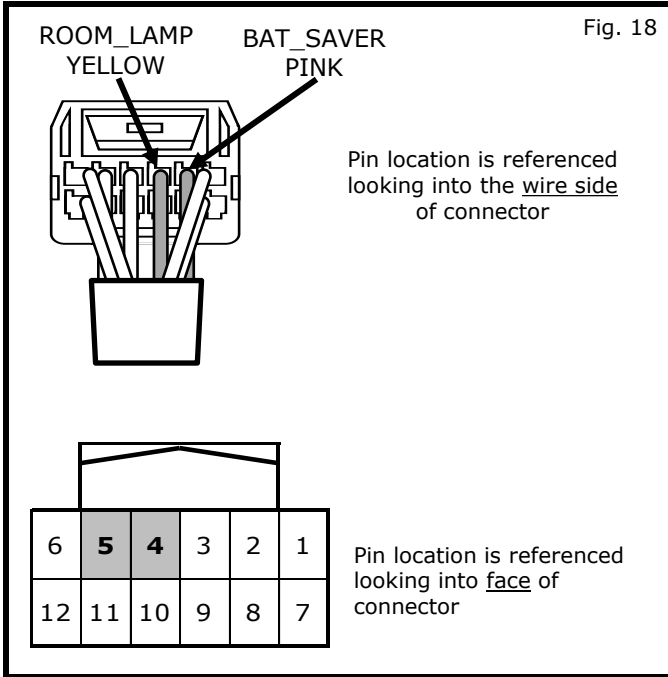

17) Accessory service connector pin out is shown in Fig. 18.

NOTES:

1.) For direction on how to posi-tap refer to Appendix A.

2.) For additional circuit information refer to Appendix B.

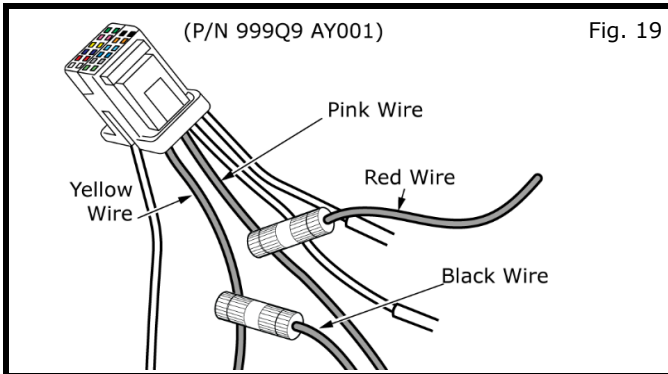

18) Using a Posi-Tap (C), connect the BLACK IKP lead wire to the "ROOM_LAMP" (YELLOW wire) of the Accessory Service Connector as shown in Fig. 17.

19) Using a Posi-Tap (C), connect the RED IKP lead wire to the "BAT_SAVER" (PINK wire) of the Accessory Service Connector as shown in Fig. 19.

INSTALLATION INSTRUCTIONS - Illuminated Kick Plate Kit

15. INSTALLATION

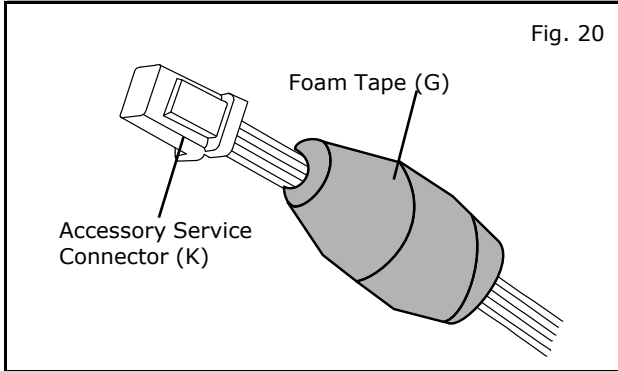

20) Wrap one Posi-Tap (H) with one (G) large foam tape (63 x 50 mm) to prevent rattle.

21) Bundle both posi-taps with a second piece of large foam tape (G) as shown in Fig 20.

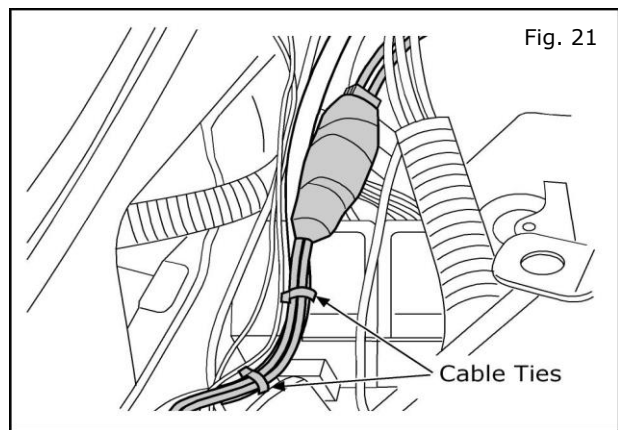

22) Plug Accessory Service Connector into the Accessory Pre-Wire Connector on the driver side. Secure with 2 cable ties as shown.

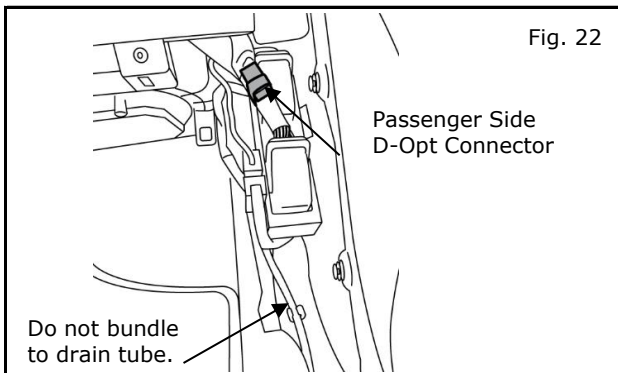

23) Locate passenger side D-Opt Connector. It will be located up under the dash in the area shown near the A-pillar.

Repeat steps 16 through 22 for passenger side.

NOTE:

A previously installed accessory may be present. If so, carefully remove the Accessory Service Connector from the Accessory Pre-Wire Connector before posi-tapping. It is recommended that all posi-tapping be completed before reattaching the Accessory Service Connector.

INSTALLATION INSTRUCTIONS - Illuminated Kick Plate Kit

15. INSTALLATION

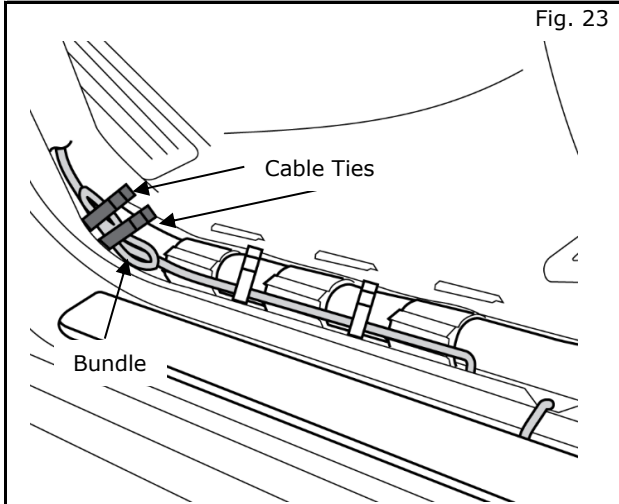

- 24) Bundle excess wire in a loop in the area shown. Secure the bundle to the existing harness with 2 cable ties. Repeat for opposite side.

NOTE:

DO NOT secure the wiring to the drain or washer fluid tubing

NOTE:

The extra wire length is provided in case there is a particular vehicle build that has placed the Accessory Pre-Wire Connector further up inside the instrument panel.

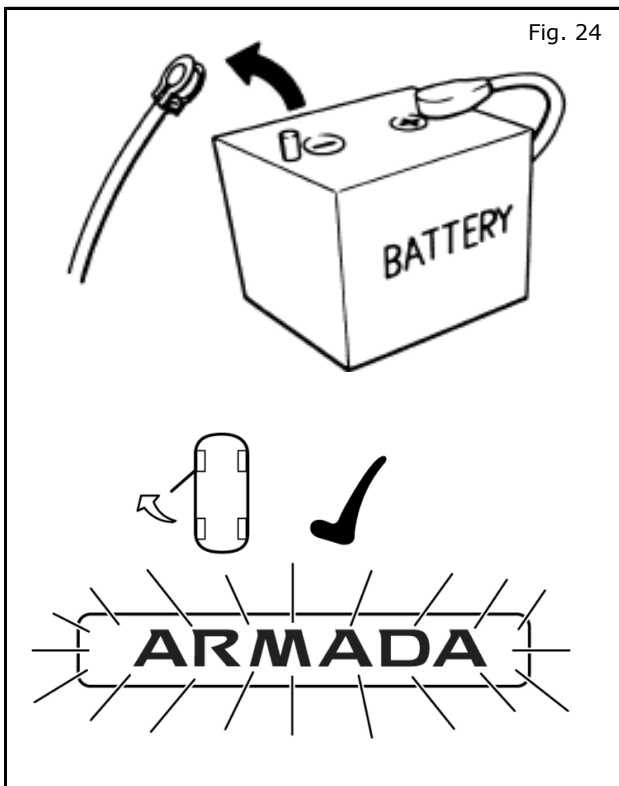

25) FUNCTION CHECK

- 1) Connect battery negative terminal.
- 2) Shut all doors
- 3) Open front left door.
- 4) On front left door, confirm that "Armada" text illuminates when door is open.
- 5) Push and hold the door status switch located on the center pillar of the vehicle. The kick plate should turn off immediately.
- 6) If kick plate does not function correctly, check harness.

NOTE:

When diagnosing electrical system problems, first disconnect the accessory connectors and note effect on system. Continue the investigation with the accessory connectors disconnected. Remember to reconnect the accessories when the investigation is complete.

- 26) Repeat function check Steps 2 - 6 with the front right door.

INSTALLATION INSTRUCTIONS - Illuminated Kick Plate Kit

13. INSTALLATION

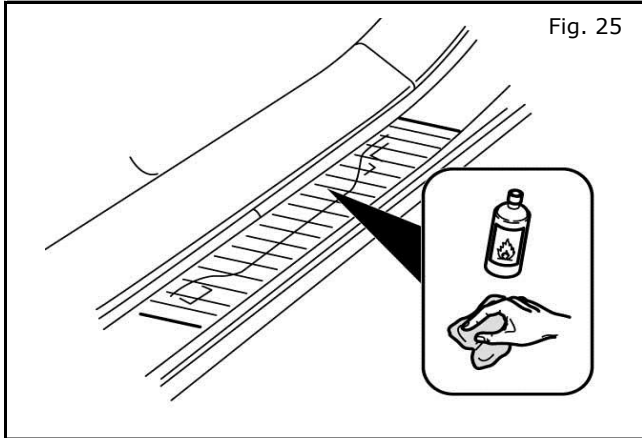

REAR DOORS (NON ILLUMINATED)

- 27) Clean area where new left rear kick plate will be attached with alcohol solution. Let dry for 30 seconds.

NOTE:

If necessary, wipe the area clean of any dirt and grime before using alcohol.

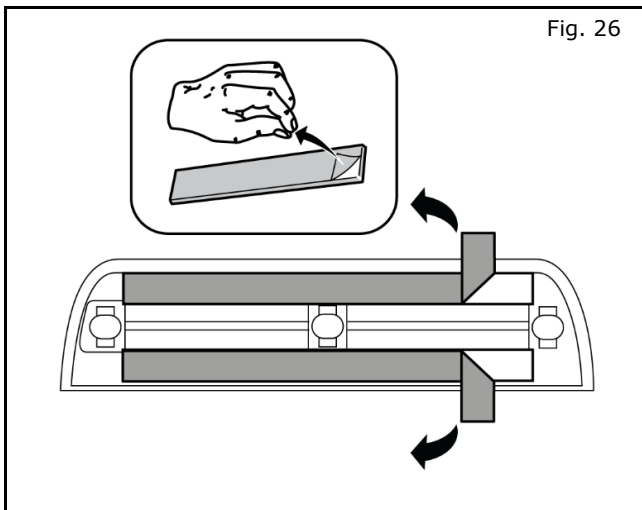

- 28) On back of kick plate, pull starter tabs to remove adhesive liners.

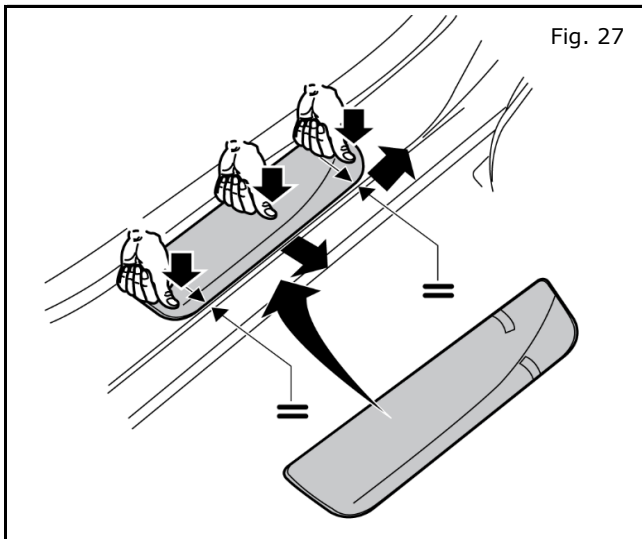

- 29) Align pins on new kick plate with holes on vehicle and position plate on vehicle. Tuck kick plate under door seal as not to pinch seal between plate and door sill.

Snap clip in smallest hole first. Then snap other two clips fully. Be careful to keep outside edge parallel to rocker panel.

- 11) Apply minimum 15 lbs. of pressure for 30 seconds along kick plate to secure adhesive.

NOTE:

Use caution when applying pressure to the kick plate to avoid denting the part.

- 30) REPEAT STEPS 24 THROUGH 29 FOR PASSENGER SIDE.

INSTALLATION INSTRUCTIONS - Illuminated Kick Plate Kit

⚠ CAUTION

DO NOT STEP ON OR WASH THE KICK PLATES FOR 24 HOURS FOLLOWING INSTALLATION.

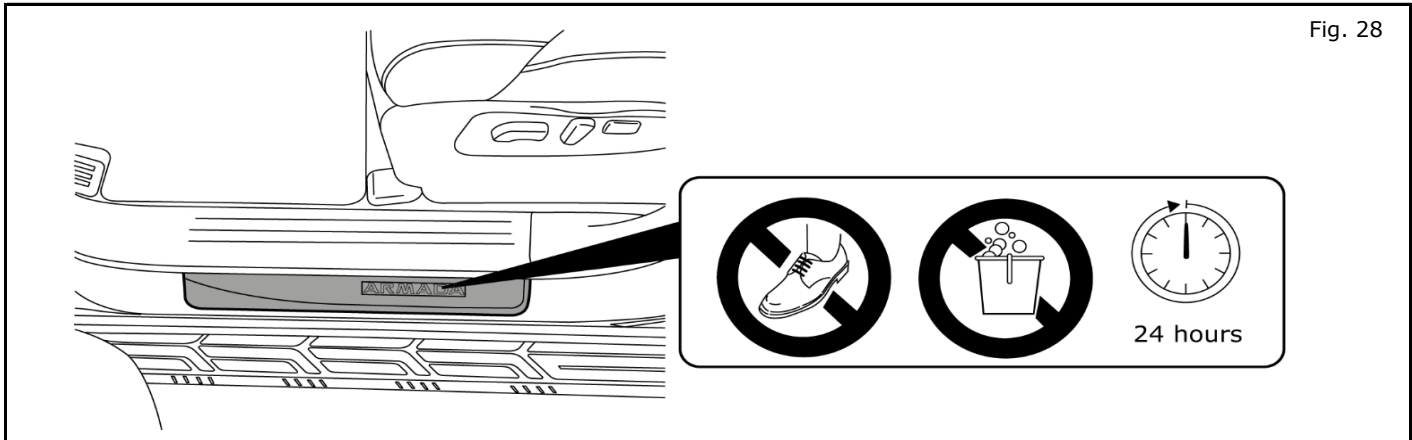

14. CHECK OUT

Inspect the vehicle for unfinished work.

- 1) Connect the battery negative terminal and tighten nut to 5.4 N-m (47.8 lb-in) .
- 2) Trim all cable ties.
- 3) Replace interior trim parts.
- 4) Verify the functionality of all electrical vehicle components where harnesses were accessed.
- 5) If this vehicle will be returned to a dealer lot or showroom for an extended period of time, be sure the extended storage switch is placed in the "inventory" position. (Refer to page 2 - Pre-Installation Notes)
- 6) If vehicle is NOT going into storage, reset the radio presets to the recorded settings.

Appendix A - Posi-Tap Procedure

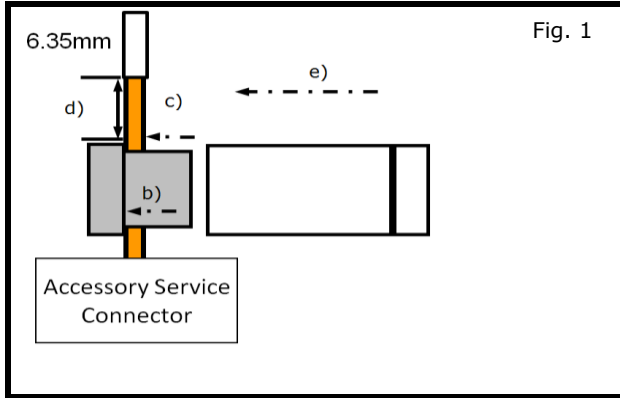

- 1) Posi-tapping an Accessory service wire (Fig. 1)
 - a) Identify and confirm correct wire in the Accessory Service Connector to be tapped.
 - b) Remove cap (slot side) from tap body.
 - c) Slide cap around single accessory wire.
 - d) Position cap $\geq 6.35\text{mm}$ (0.25in) away from the heat shrink end of Accessory Service Connector (measurement for first posi-tap installed on the circuit).
 - e) Tighten the tap **TIGHT** with finger pressure.
 - f) Tighten by another quarter turn.

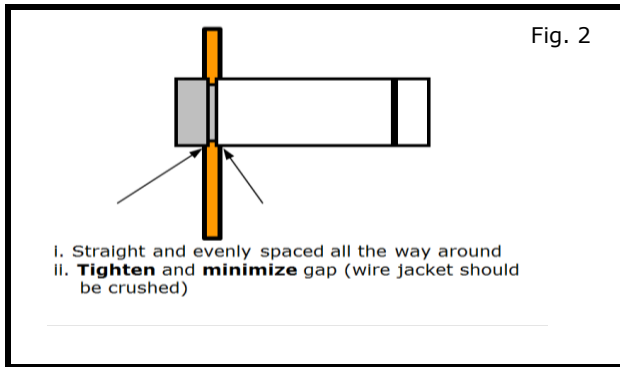

- 2) Inspecting the tap for correct installation (Fig. 2).
 - a) Pull on the wire lightly to ensure connection.
 - b) Inspect the tap to ensure correct installation.

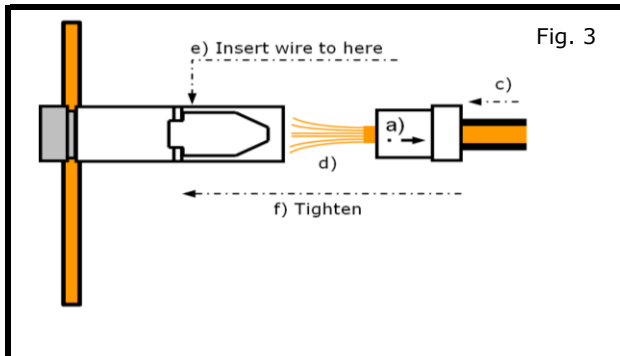

- 3) Tap accessory wire (Fig. 3).
 - a) Remove tap (non-pierce) side from tap.
 - b) Remove the protective stub from the wire.
 - c) Insert wire through the non-pierce side opening.
 - d) Spread the individual strands into fan shape.
 - e) Insert wire into the tap body and ensure that it is all the way in.
 - f) Tighten the tap **TIGHT** with finger pressure.
 - g) Tighten by another quarter turn.

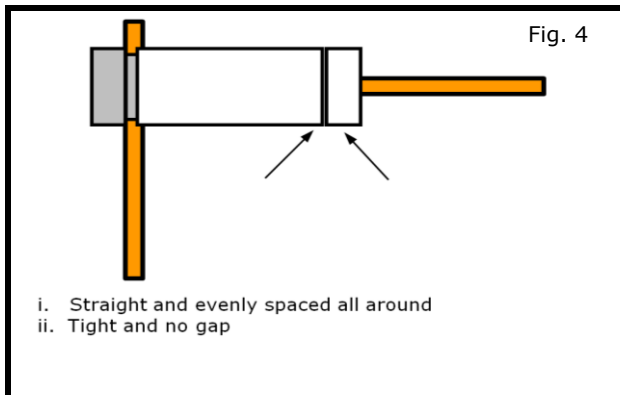

- 4) Confirm the tapped accessory wire.
 - a) Pull on the wire lightly to ensure connection.
 - b) Inspect the tap to ensure correct installation as shown in Fig. 4.

Appendix A - Posi-Tap Procedure

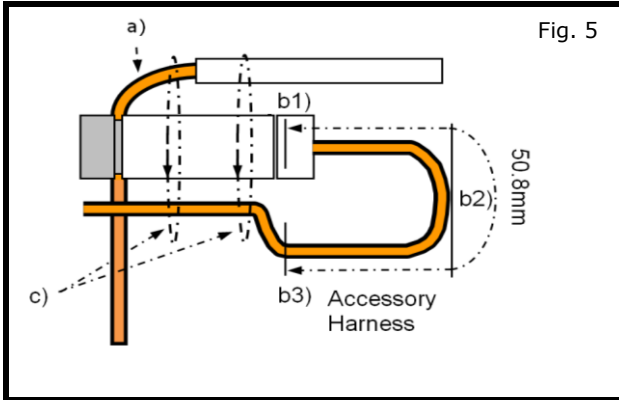

- 5) Forming strain relief loop - required (Fig. 5).
 - a) Gently bend end of pierced wire (where it exits cap) down towards body of posi-tap.
 - b) On tapped side wire; starting at point b1), measure 50mm to point b3). Make first bend of loop b2), half measured distance - 25mm, and up toward body of posi-tap, make second bend of loop b3).
 - c) Secure pierced wire on heat shrink side and tapped wire to body of tap with electrical tape (≥ 2 revolutions).

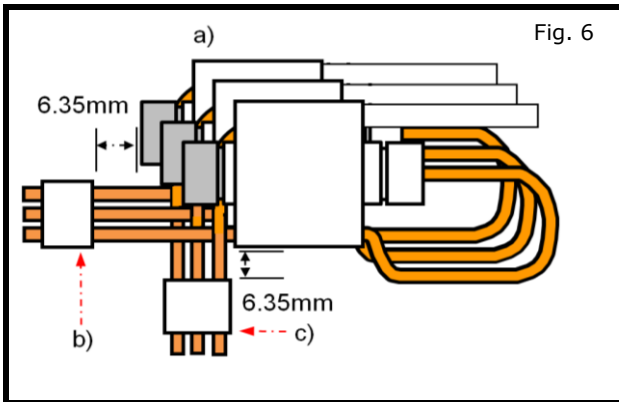

- 6) Securing multiple accessory taps (Fig. 6).
 - a) Tapped accessories (wires already secured to tap bodies) are stacked in a stagger on top of each other as shown in Fig a).
 - b) Secure tapped wires on connector side of posi-taps to each other with electrical tape (≥ 2 revolutions) at a distance of ≥ 6.35 mm as shown in Fig b).
 - c) Pierced wires of posi-taps are secured to each other with electrical tape (≥ 2 revolutions) at a distance of ≥ 6.35 mm (0.25in) as shown in Fig c).

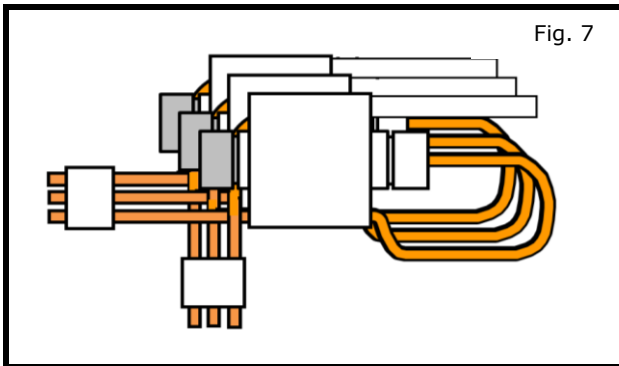

- 7) Securing multiple accessory taps (Fig. 7).
 - a) Make sure the accessory taps have been wrapped appropriately as detailed previously and as shown.

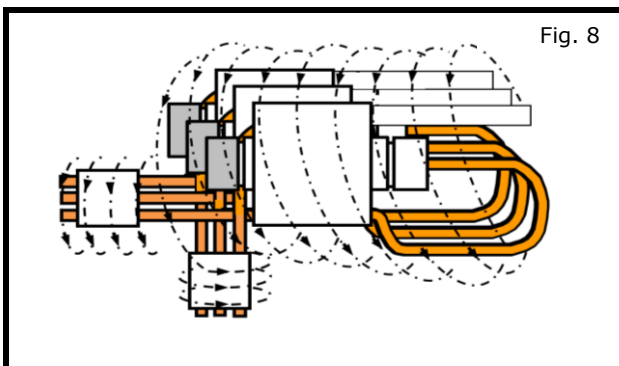

- 8) Securing multiple accessory taps
 - a) Starting at heat shrink; firmly wrap posi-tap bundle with electrical tape or non-adhesive wire harness tape, making sure to overlap previous revolution.

Note: If using non adhesive tape secure at the of wrap with electrical tape ≥ 2 revolutions.

Appendix A - Posi-Tap Procedure

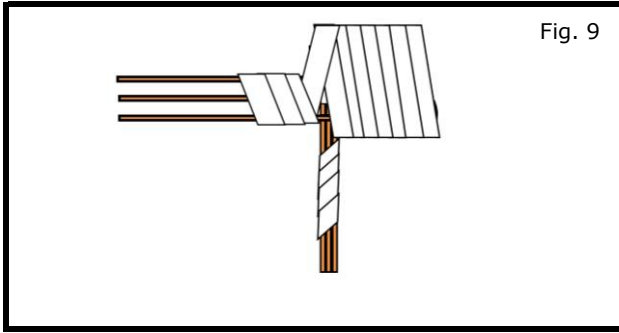

- 9) Securing multiple accessory taps
a) Make sure the finished wrap looks similar to Fig. 9.

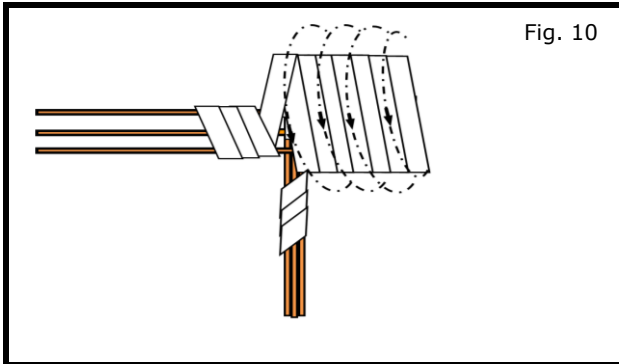

- 10) Foam wrap for posi-tap bundle (foam strips)
a) Wrap the posi-tap bundle with foam tape, following a pattern similar to the electrical tape, making the best use of foam strips provided.

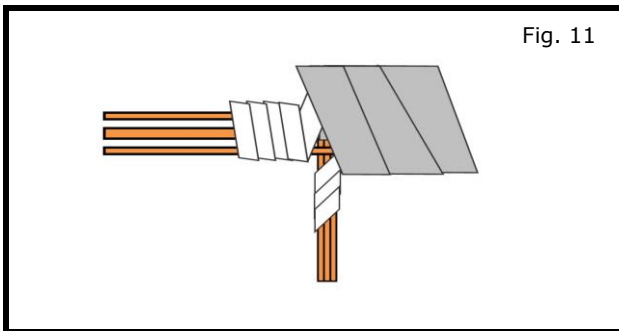

- 11) Finished foam wrap for bundle (strips-top view)
a) Make sure the finished wrap looks similar to Fig. 11.

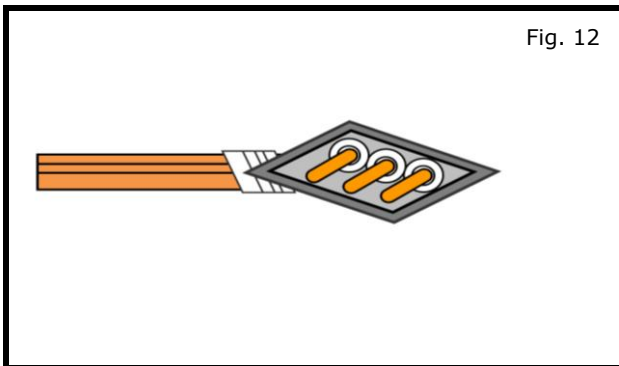

- 12) Finished foam wrap for bundle (strips-side view)
a) Make sure the finished wrap looks similar to what is shown in Fig. 12.

NOTE:

Posi-Tap™ is protected by patent # 5,228,875 5,695,369 5,868,589 6,692,313 Jap 2881414 Aus 708700 Tia 103534 Can 2204826 Mex 200626 Korea 477279 China Z197105562.9 & others pending.

ILLUMINATED KICK PLATE KIT

ACCY_SER_CONN

IGN	1	White	_____
BAT	2	Red	_____
TAIL_LAMP	3	Purple	_____
ROOM_LAMP	4	Yellow	_____
BAT_SAVER	5	Pink	_____
FR_DOOR_SW_RH	6	Green	_____
FR_DOOR_SW_LH	7	LT Green	_____
THRU_SIGNAL_1	8	Gray	_____
RR_DOOR_RH	9	Blue	_____
RR_DOOR_LH	10	LT Blue	_____
ACC	11	Orange	_____
GND	12	Black	_____

TH12FW-NH

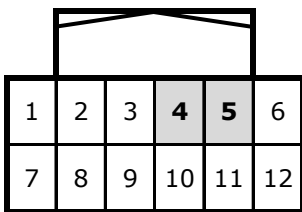

Note: Pin location is referenced looking into wire side of connector.

ILLUMINATED KICK PLATE

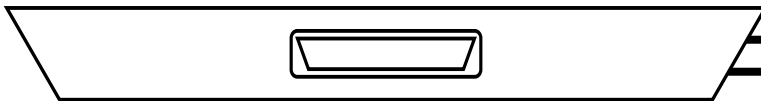

Red

Black

