



# GENUINE PARTS

## INSTALLATION INSTRUCTIONS

<b>DESCRIPTION:</b>	Welcome Light Kit
<b>APPLICATION:</b>	Nissan Maxima
<b>PART NUMBER:</b>	T99F4 5CH1B -Welcome Lighting Kit. T99F4 4RA5BII - Installation Instructions (WEB) T99F6 4RA0A - Accessory Service Connector

### KIT CONTENTS:

Item	QTY	Description	Service Part Number
A	1	Control Module	NA Part of T99F4 5CH1B
B	1	LED Assembly LH	
C	1	LED Assembly RH	
D	1	Misc parts kit (see BOM for details)	
<b>ITEMS NOT IN KIT THAT MAY BE REQUIRED:</b>			
	2	Accessory Service Connector	T99F6 4RA0A

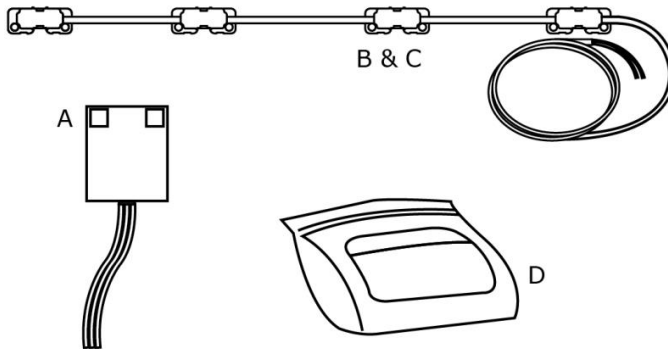

**NOTE:  
ACCESSORY  
HARNESS MAY BE  
REQUIRED.  
NOT INCLUDED  
IN KIT.  
REFERENCE  
PART NUMBER  
T99F6 4RA0A.**



### TOOLS REQUIRED:

- Trim Tool
- Small Flat Bladed Screw Driver
- 6mm (15/64") drill bit
- Electrical Tape

### PRE-INSTALLATION WARNINGS, CAUTIONS, CRITICAL STEPS, and NOTES:

- Dealer Installation Recommended. Instructions may refer to Service Manual.
- Installation requires special tool(s)
- This part is to be installed within a surface temperature range of 70-100°F

## **⚠ WARNING**

- **This accessory must only be installed as specified in these instructions.**
- **Ensure at all times that parts are securely fitted and will not compromise the safe function of vehicle systems.**

# INSTALLATION INSTRUCTIONS - Welcome Light Kit

## INSTALLATION OVERVIEW:

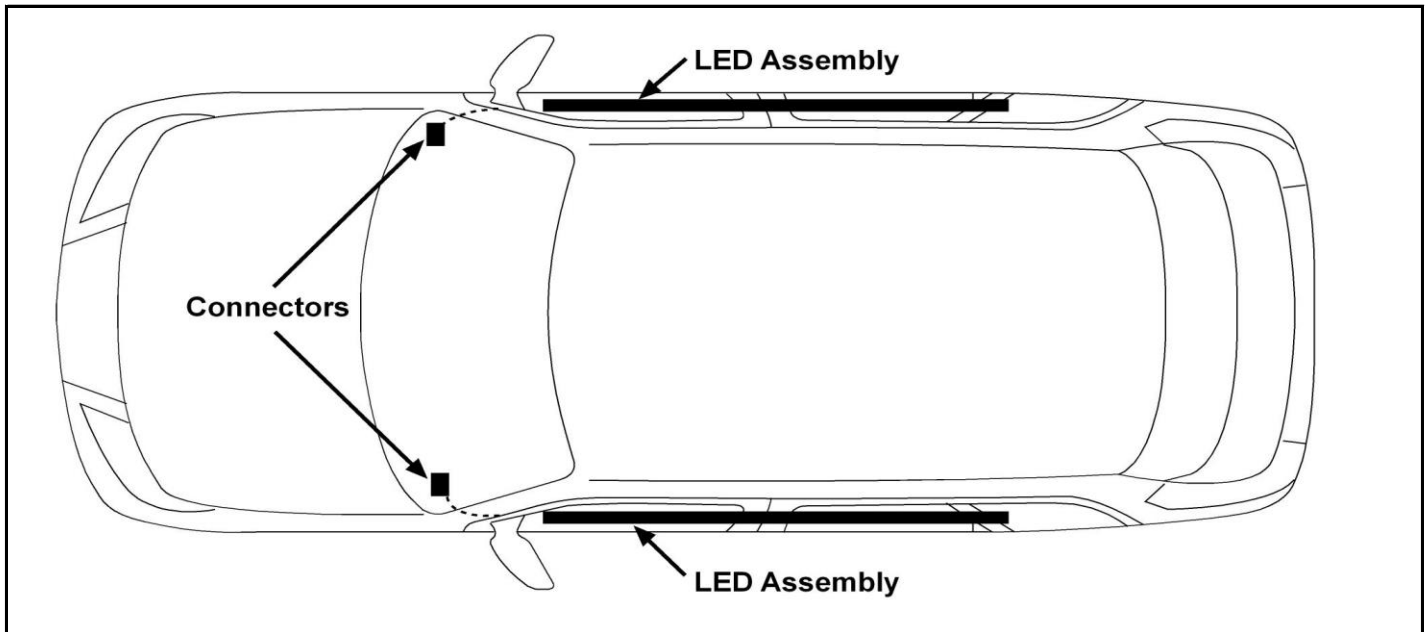
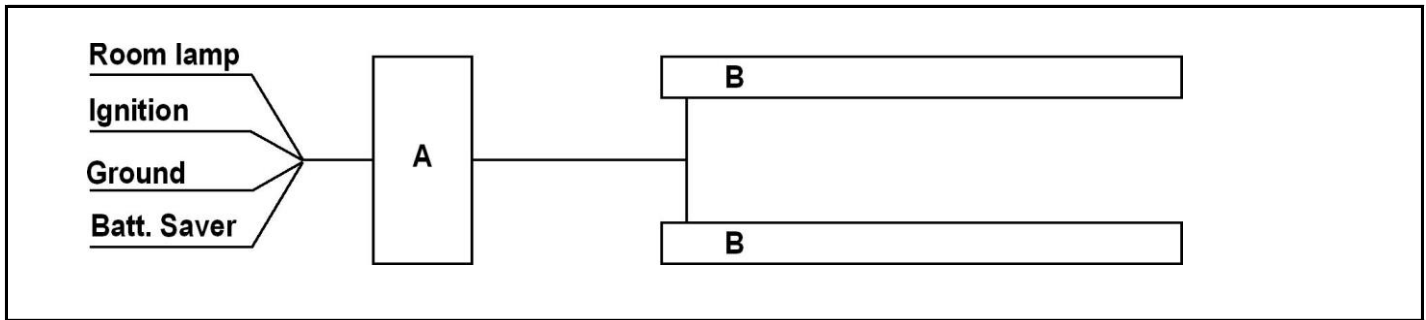

## **⚠ CAUTION**

### **CRITICAL STEPS TO DISCONNECT BATTERY:**

- Allow 3 min after key off and doors closed for vehicle to time out (if doors are opened again additional time may be required). Disconnect negative terminal. Allow an additional 3 min after negative terminal disconnect before separating any electrical connectors.

## **8. CRITICAL STEPS**

The following steps are critical and must be performed **EXACTLY** as specified to ensure proper installation:

- Location of the lights must be followed exactly as described in this instruction.
- Posi-Tap™ instructions must be specifically followed as described.
- Be sure to apply masking tape as needed in order to protect any areas that may become scratched or damaged by tools.
- Be sure to apply foam tape to any wiring components that can be damaged over time by sharp edges.
- Test the functionality of the kit before final clean up and reinstallation of interior panels.

**Vehicle Preparation:**

**⚠ CAUTION**

- Always confirm the ignition is in the "OFF" position before changing the switch condition.

- 1) Apply parking brake
- 2) Confirm vehicle is not in the default shipping state or "Inventory position" as shown below. Failure to confirm vehicle has been removed from this state will result in loss of normal vehicle operation.
- 3) Locate Extended Storage Switch in cabin fuse block. Confirm it is in the "Customer" position. See below for reference.
  - a) To remove transit mode (Fuse Block):
    1. Remove fuse cover lid.
    2. Push down shorting pin.
    3. Ign On 2 times without starting the vehicle.
  - b) To remove transit mode (BCM):
    1. Confirm ignition switch is in "OFF" position.
    2. Simultaneously push the signal and wiper switch fully down for two (2) seconds.

**NOTE:** While in BCM Transit Mode, turn signal indicators will remain illuminated for one minute.

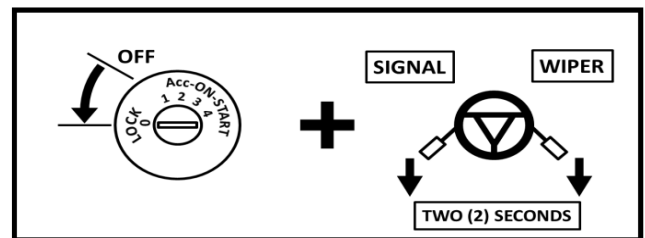
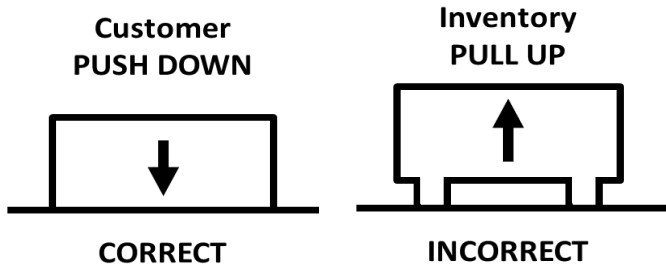

- c) To return to transit mode for storage:
  1. Ign Off.
  2. Remove fuse cover lid.
  3. Pull up shorting pin.
  4. Assemble fuse cover lid.
  5. Ign On 2 times without turn the vehicle on.
  6. Confirm transit mode condition on meter

**NOTE:** Typical vehicle condition shown above. Switch is easily identifiable by the permanent, push-pull fuse holder. Actual position on the fuse block may vary, vehicle to vehicle.

Condition	Switch Position	Note
Vehicle is delivered to the dealer	Inventory Condition	
Technician performs PDI	Customer Delivery	Return to Inventory position after PDI.
Customer test drives the vehicle	Customer Delivery	Return to Inventory position after test drive.
Vehicle is being stored at the dealer	Inventory Condition	
Vehicle is delivered to customer	Customer Delivery	

**NOTE:** The Extended Storage Switch is only an aid to improve battery life during vehicle storage at the dealer. If the Extended Storage Switch fuse ever needs service after vehicle delivery, discard the Extended Storage Switch and install the correct fuse in its place.

- 4) Turn ignition switch to "ON" position
- 5) Record the customer radio presets and other presets as required.

Preset	1	2	3	4	5	6		

- 6) Put shift lever in "P" position for A/T and CVT or "1st" for M/T
- 7) Turn ignition switch to "OFF" position
- 8) Use seat and floor protection.

## VEHICLE PREPARATION

### **⚠ WARNING**

- **FOR VEHICLES WITH MANUALLY OPERATED SEATS: Disconnect negative battery terminal before proceeding.**
- **FOR VEHICLES WITH POWER SEATS: Disconnect negative battery terminal AFTER Step 3.**

### **⚠ CAUTION**

- **Allow 3 min after key off and doors closed for vehicle to time out. Allow an additional 3 min after negative terminal dis-connect before separating any electrical connectors.**

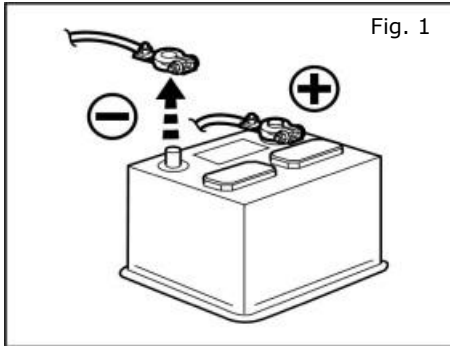

- 9) Move both front seats rearward and up.  
Disconnect negative battery terminal as shown.

## ORDER OF INSTALLATION

1. Remove panels and trim.
2. Prepare mud guards
3. Install LED Assemblies
4. Route Wiring
5. Install controller
6. Reinstall all panels
7. Final Check Items

# INSTALLATION INSTRUCTIONS - Welcome Light Kit

## VEHICLE PREPARATION

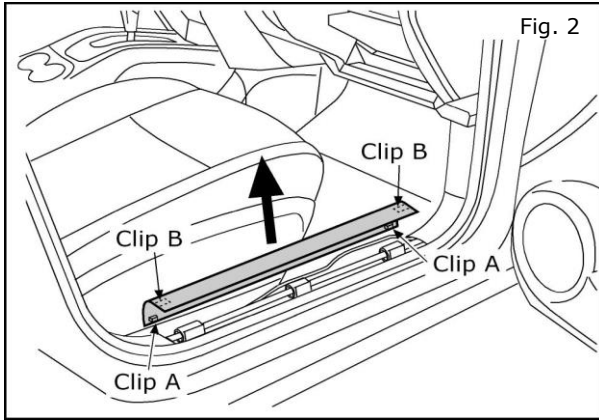

## BEGIN ON PASSENGER SIDE

- 1) Remove inner door sill trim panel.
- 2) Place fingers at clip (A) which is located at inner rear and front end, and pull out with a slight rotating motion until clip A is popped loose, then pull up to remove door sill trim panel.
- 3) Move passenger seat to full back position.
  - a) **For vehicles with power seats**, disconnect negative battery terminal at this time. Refer to Page 4, Fig. 1 for battery removal instructions.

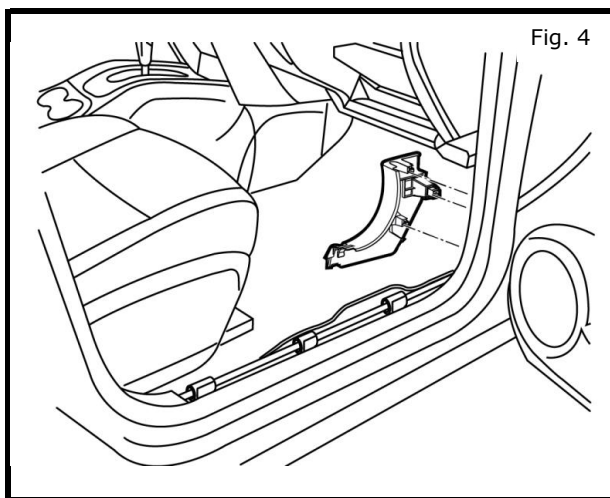
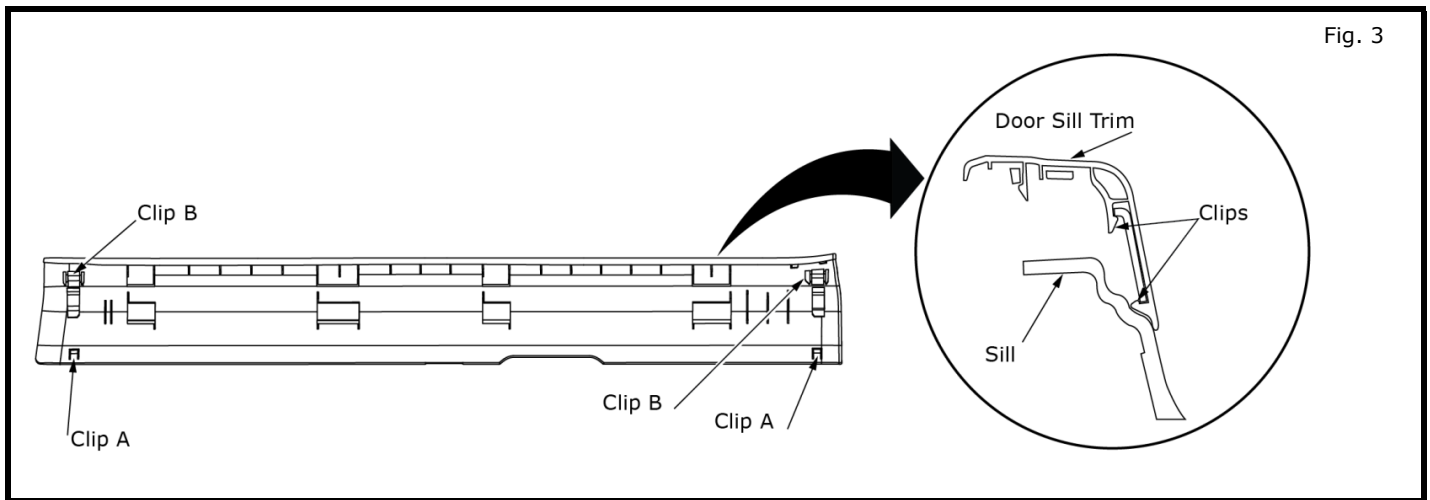

- 4) Remove one fastener from outer footwell trim panel (RH). Use a trim stick to carefully pry off trim panel, pulling part horizontally toward center of vehicle.

### NOTE:

**Be careful not to damage clip on lower portion of panel.**

# INSTALLATION INSTRUCTIONS - Welcome Light Kit

## VEHICLE PREPARATION:

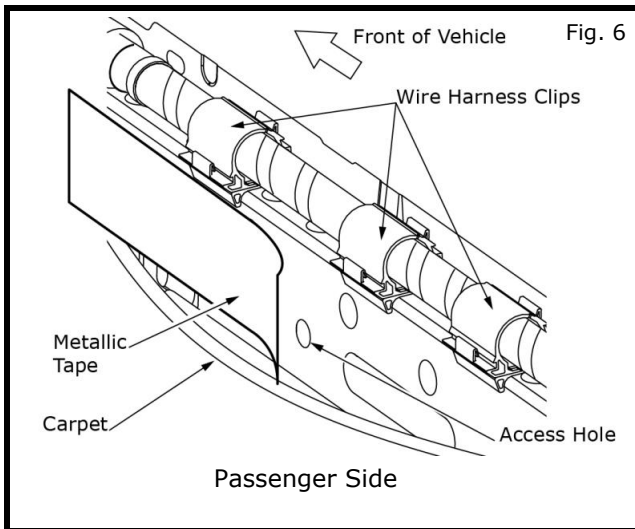
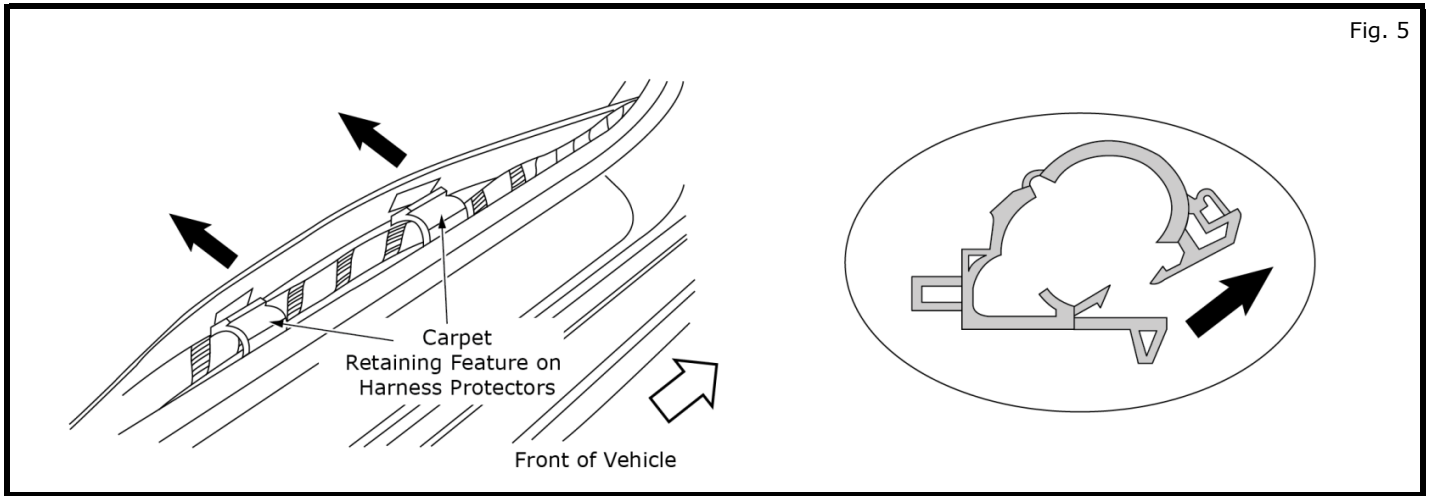

- 5) Open three (3) plastic wire harness clips from inside passenger side door sill. Carefully pull back carpet edge.
- 6) Carefully peel back metallic tape to expose the access hole on the inside edge of passenger side door sill. Mastic must be cut (slit along hole centerline from rear of vehicle to the hole center to allow reinstall of mastic over harness).

**NOTE:**

**If hole is only covered by a small foam tape remove and clean surrounding surface.**

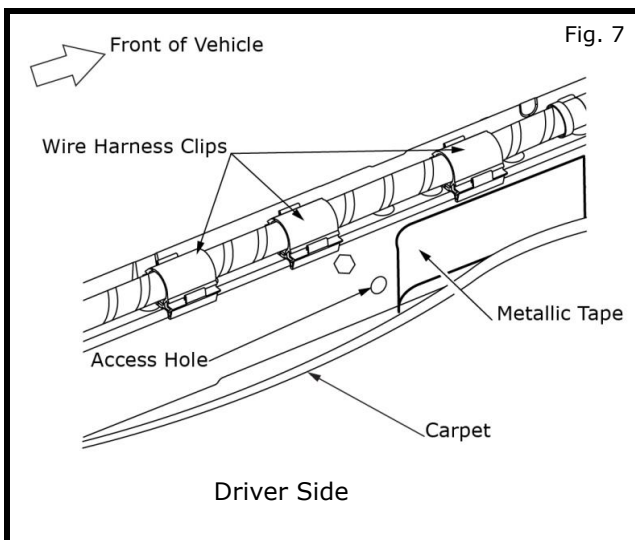

- 7) **REPEAT STEPS 1 THROUGH 6 FOR DRIVER SIDE OF VEHICLE.**

- 8) **RAISE VEHICLE**

**NOTE:**

**Use caution when placing lift pads. Refer to users manual to identify lift points on body.**

# INSTALLATION INSTRUCTIONS - Welcome Light Kit

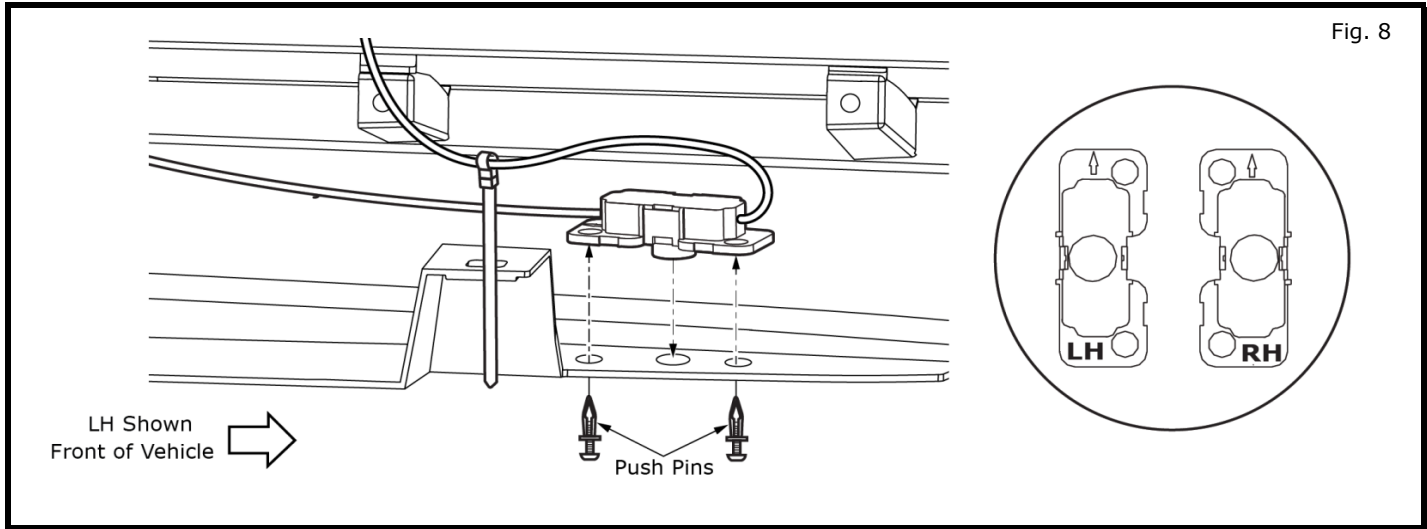

- 9) Starting at end module without wires at both ends (see Fig. 8), carefully feed LED string through mud guard from front of vehicle to rear of vehicle. Place lens of LED into last hole, being sure to align attachment holes with holes in mudguard, use two (2) push pin fasteners to attach LED bracket to mudguard as shown. Continue attaching LED's towards front of vehicle for remaining length of mudguards.

**NOTE:**

- **Verify before attachment that you are using the LED string marked "LH" with the left side mud guard and marked "RH" with the right side mud guard (see Fig. 8).**

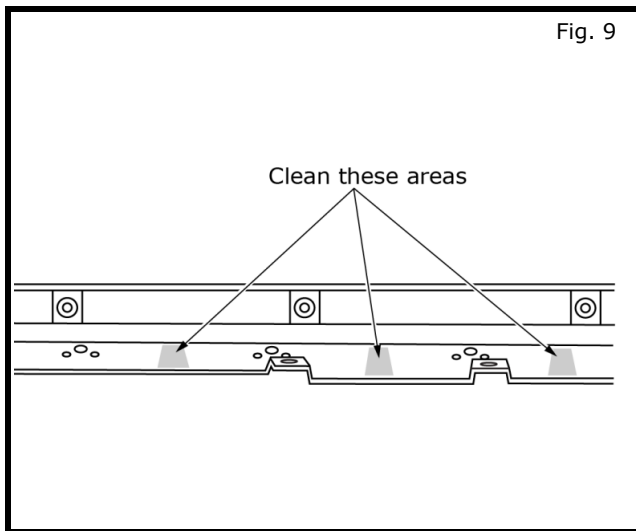

- 10) Clean inside surface of mud guard where retaining tape will be mounted with alcohol prep pad(s) at areas shown. **Wipe both mud guards. Allow minimum of 1 minute to be sure alcohol is completely dry.**

**NOTE:**

- **It may be necessary to first blow out the inside of the mud guard with compressed air and/or wipe with a damp cloth.**
- **Be sure installation temperature is within a range of 70-100°F for adhesive to adhere to mudguard.**

# INSTALLATION INSTRUCTIONS - Welcome Light Kit

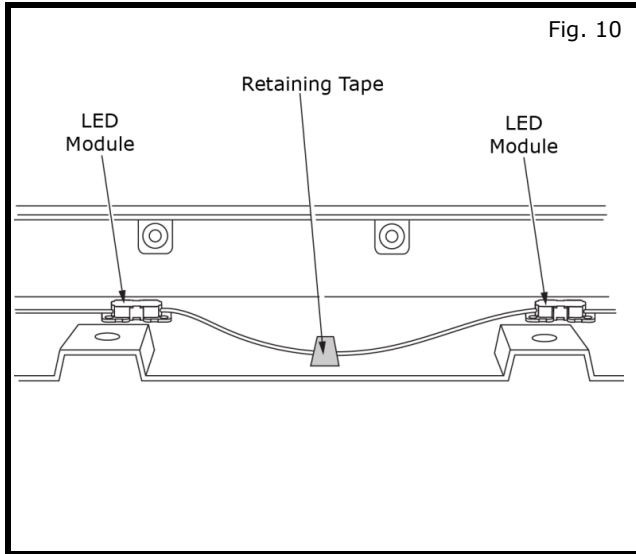

- 11) Repeat Step 9 with remaining three LED modules. Ensure wiring between module does not become twisted as you are installing to mud guard. Once all LED modules are in place, cut one piece of retaining tape in half longway and secure wiring as shown.

## CAUTION

- Pull the wires between the module toward the middle of the vehicle (as shown in Fig. 9) before taping to prevent wire damage if the Rocker Moulding strip is added to the mudguards.

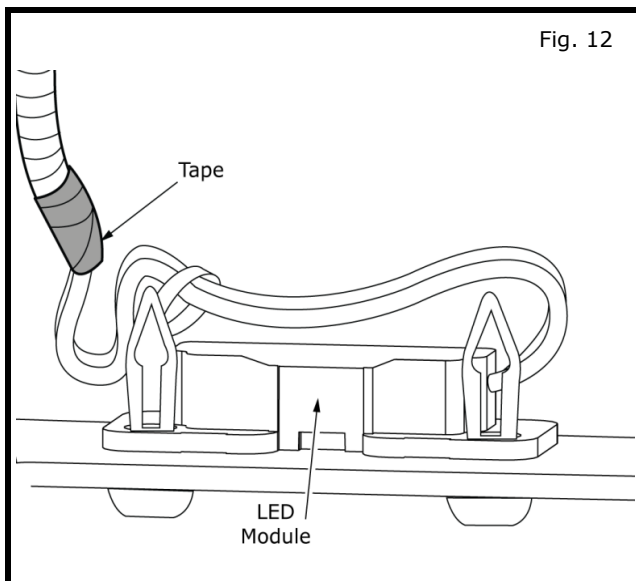
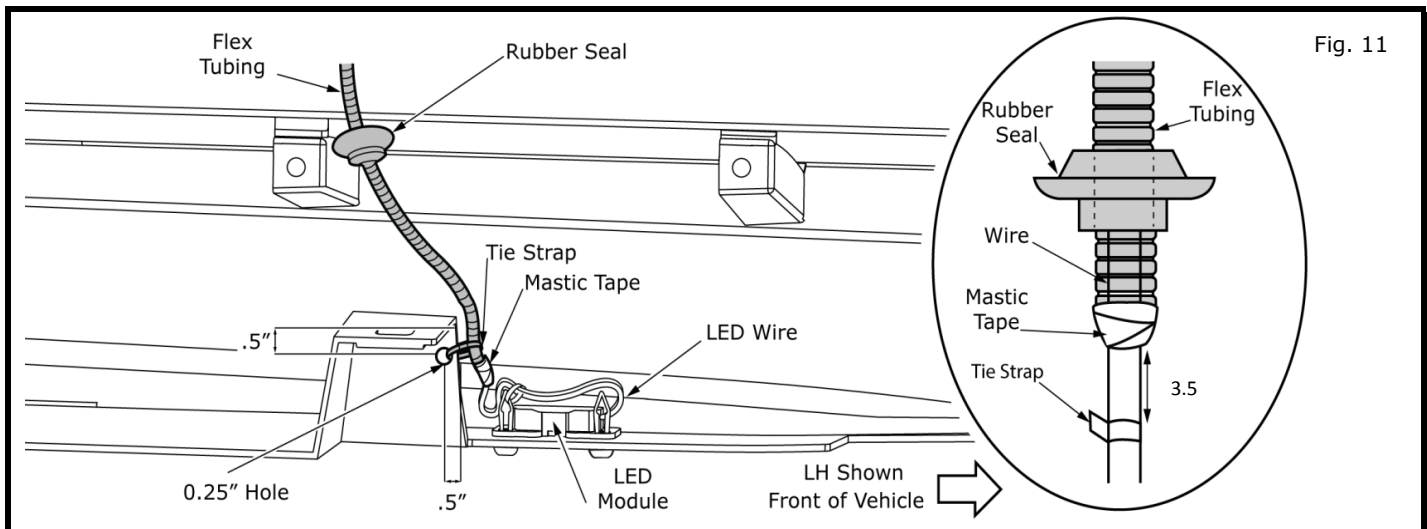

- 12) Drill 0.25 in hole in mudguard bracket by LED at front of vehicle; 1/2 in by 1/2 in as shown in figure 11, on both left and right bracket.

- 13) From below vehicle, feed one rubber seal (small) and protective flex tubing provided in kit over the wire extending from front LED module. (See Figure 12).

### NOTE:

**Be sure the beveled side of the seal is facing AWAY from LED module.**

- 14) Apply mastic sealant to flex tube. Cover with electrical tape. Apply mastic approximately 100 mm from double tie strap on wire. (See Fig. 12)



# INSTALLATION INSTRUCTIONS - Welcome Light Kit

## INSTALLATION PROCEDURE:

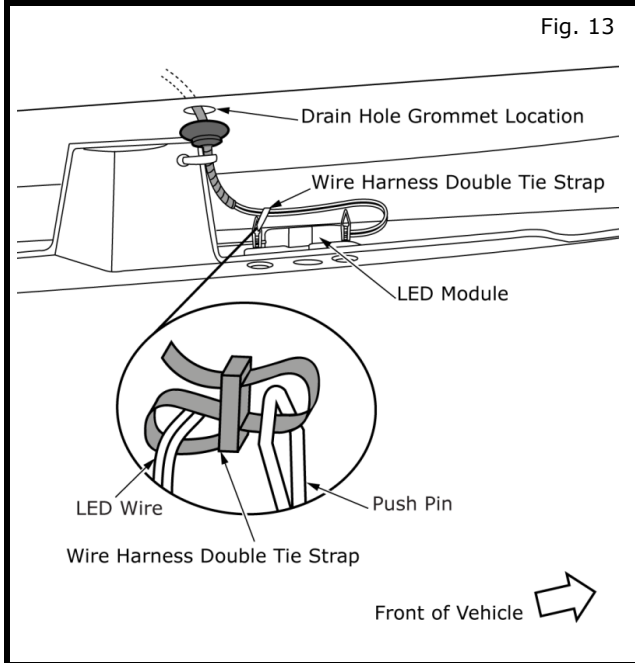

15) On underside of mudguard, locate drain hole grommet shown in Fig. 13 and remove (discard).

16) Attach wire harness double tie strap to push pin loop as shown in figure 13. Route flex tube toward body and attach flex tube to hole drilled in mudguard bracket with tie strap as shown.

### NOTE:

**Ensure wire harness double tie strap is attached to wire and push pin EXACTLY as shown.**

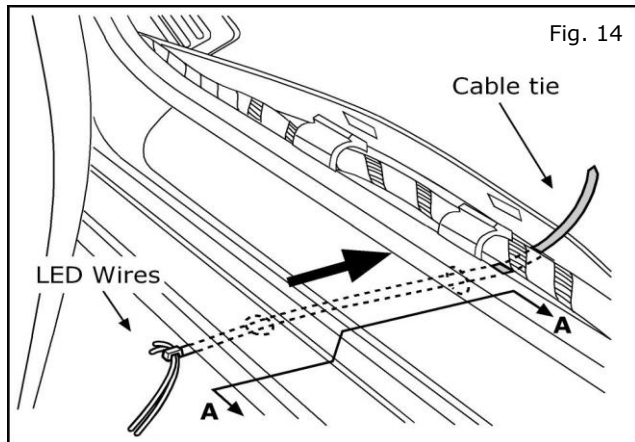

17) From inside vehicle, feed tie strap into hole in door sill (see Fig. 14). Route tie strap through sill as shown.

18) Next, feed wires through the end of a long cable tie. Use cable tie to route the wires through hole in side of vehicle and through access hole inside door sill.

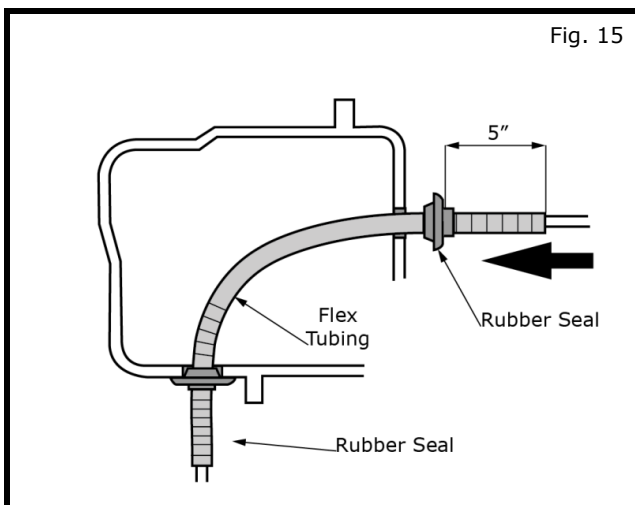

19) Press inside rubber seal into position. Pull excess flex tubing inside the vehicle.

### NOTE:

**Make sure both seals, top and bottom, are properly installed. Four (4) small grommets are used for this installation and two (2) large grommets are extra.**

# INSTALLATION INSTRUCTIONS - Welcome Light Kit

## INSTALLATION PROCEDURE:

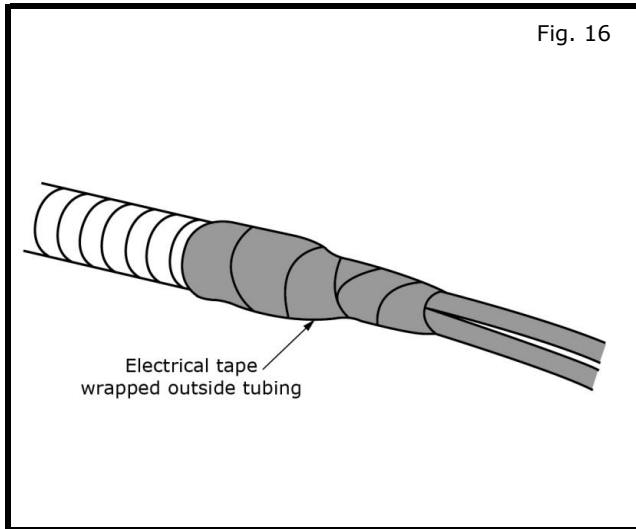

20) Tape wire to flex tube on inside of vehicle as shown in figure 16.

### REPEAT PROCESS ON OPPOSITE SIDE OF VEHICLE

21) Once grommet is seated tape end of flex tube and wires.

#### NOTE:

**If there is no mastic, or hole was only covered by small foam tape, move on to step 23.**

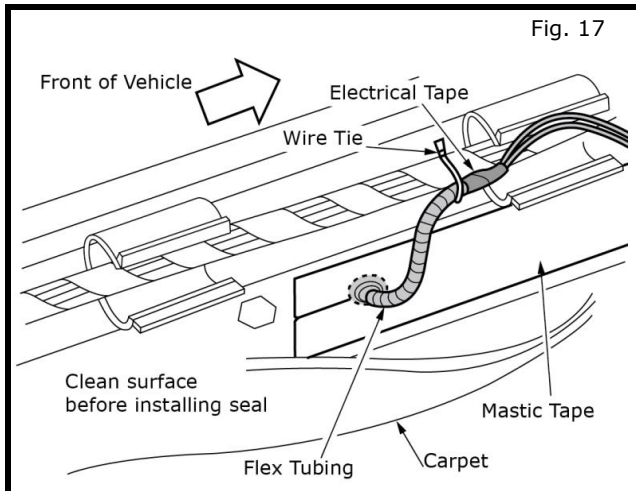

22) Re-seat metallic tape, if in vehicle, as shown in figure 17.

#### NOTE:

**Recommended spacing for cable ties is 100mm to 120mm. Position cable ties as shown.**

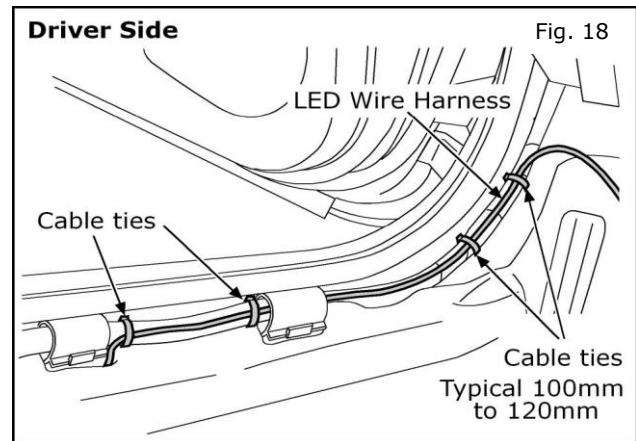

23) Route wires from driver side up towards the dash by running wires along the existing harness and securing with cable ties.

# INSTALLATION INSTRUCTIONS - Welcome Light Kit

## INSTALLATION PROCEDURE:

### ⚠ CAUTION

- If a vehicle wire is being used by another accessory and a posi-Tap is present, tap the accessory wire **NOT** the vehicle wire.

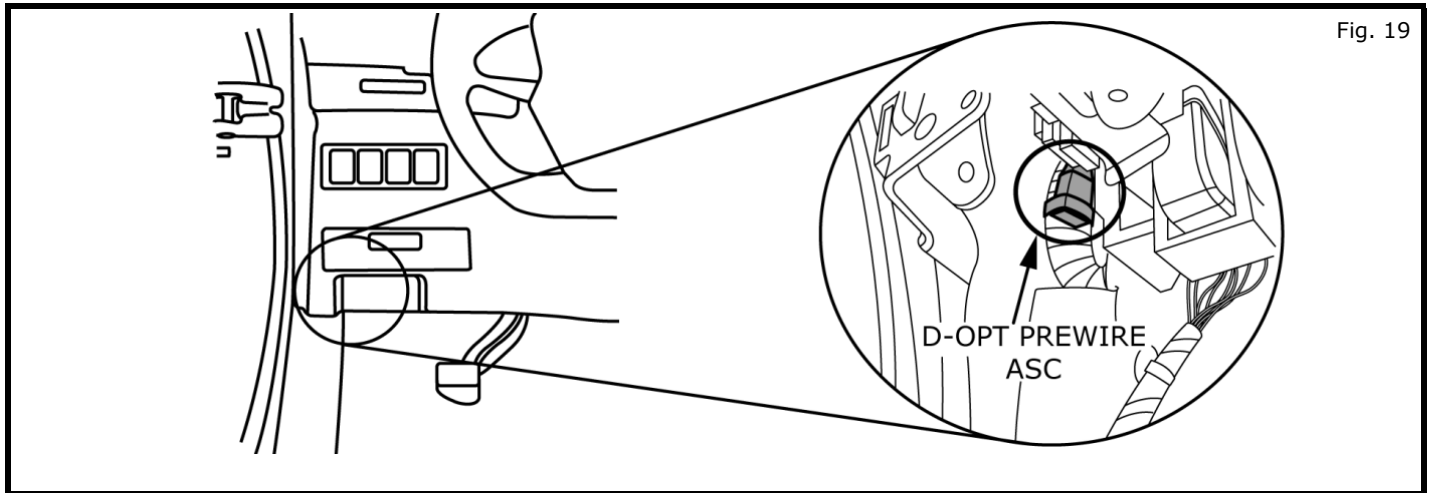

Fig. 19

24) Locate driver side Accessory Service Connector plug. It will be taped to harness below dash along outer wall of footwell.

Prepare Driver side Accessory connector:

a) Locate driver side D-Opt Connector plug. It will be taped to harness below dash along outer wall of footwell.

b) A previously installed accessory may be present. If so, carefully remove the accessory connector harness from the accessory connector plug and remove all foam tape before posi-tapping. It is recommended that all posi-tapping be completed before reattaching the accessory connector harness to the plug.

c) If there is not a previously installed accessory, remove the dummy plug in connector. See detail.

# INSTALLATION INSTRUCTIONS - Welcome Light Kit

## ACCESSORY CONNECTOR MECHANIZATION: FOR DRIVER SIDE L.E.D. HARNESS ONLY

### ⚠ CAUTION

- This Accessory Service Connector is for use only with Genuine Nissan (or Infiniti) or Nissan (or Infiniti) approved accessories. Use of this connector with non Genuine Nissan (or Infiniti) or Nissan (or Infiniti) approved accessories or failure to follow the installation instructions for said connector being mentioned herein may result in damage to the accessory and/or your vehicle. Nissan (or Infiniti) is not liable for loss or damage due to improper installation or the installation of non Genuine or non approved accessories.

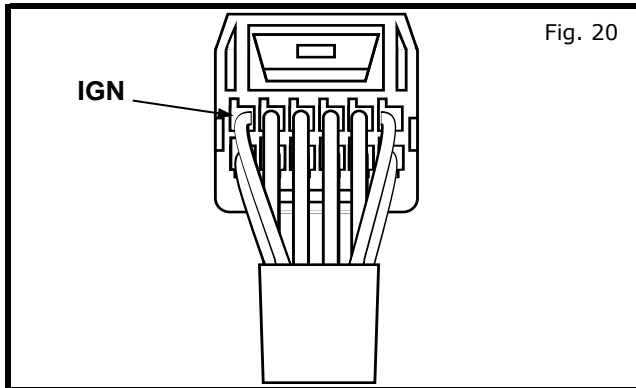

25) Locate ignition wire on Accessory Service Connector.

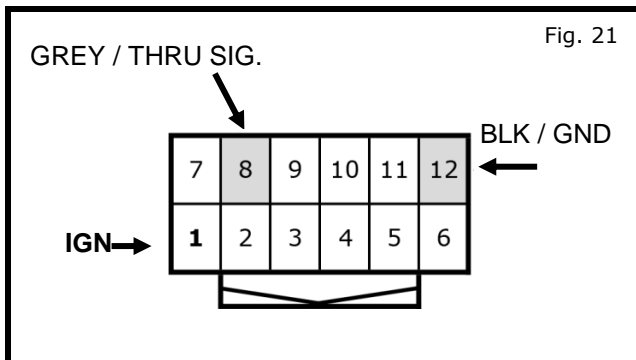

### NOTE:

**Pin location is referenced looking into face of connector.**

26) Use posi-taps to connect wiring as follows (see posi-tap instructions on pages 13-15):

- Black** wire from LED Harness to **Black** wire on Accessory Service Connector Harness.
- Red** wire from the LED Harness to the **Grey** wire on the Accessory Service Connector Harness.

Fig. 22

T99F6 4RA0A		
Pin	Label	Color
1	IGN	WHITE
2	BAT	RED
3	TL_LMP	PURPLE
4	RM_LMP	YELLOW
5	BATSVR	PINK
6	FR_DR_SW_RH	GREEN
7	FR_DR_SW_LH	LT GREEN
8	THRU SIGNAL 1	GREY
9	RR_DR_RH	BLUE
10	RR_DR_LH	LT BLUE
11	ACC	ORANGE
12	GND	BLACK

# INSTALLATION INSTRUCTIONS - Welcome Light Kit

Fig. 23

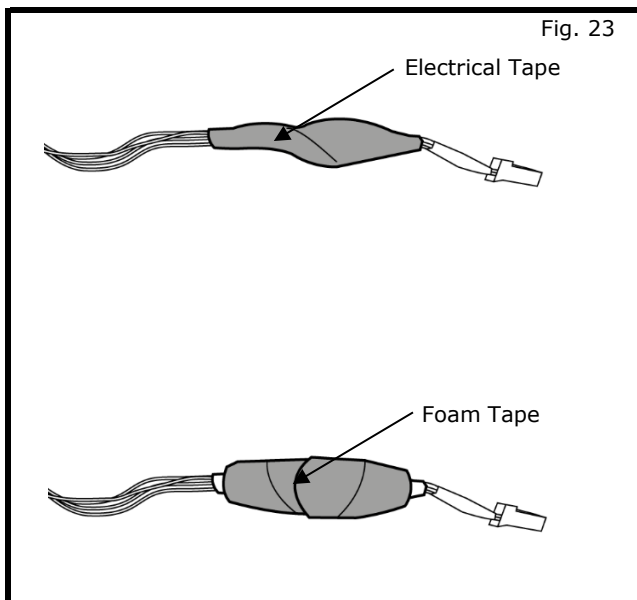

- 27) Wrap posi taps and any excess wiring from LED harness to the Accessory connector harness and with electrical tape as shown.
- a) After wrapping in electrical tape cover bundle with foam tape.
  - b) Plug Accessory Connector Harness into vehicle connector plug on driver side.

Fig. 24

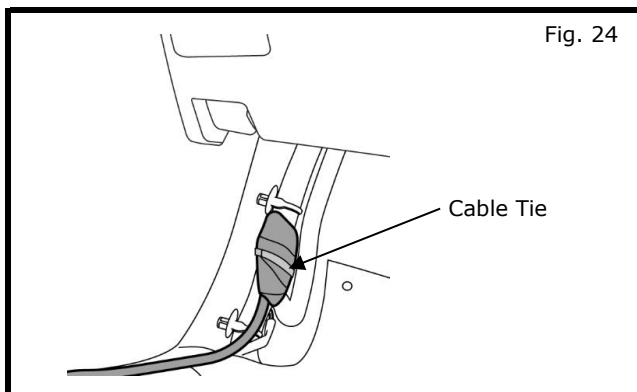

- 28) Tie strap posi taps and excess harness to main harness as shown.

**NOTE:**

Refer to Posi-Tap steps on pages A1 - A3 for proper wire wrapping procedures.

**HARNESS NOT INCLUDED IN KIT. REFERENCE PART NUMBER 999Q9 AY001.**

Fig. 25

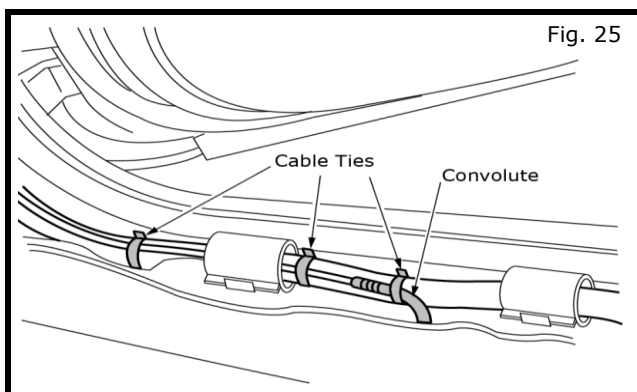

- 29) Route wires from passenger side up towards dash by running wires along existing harness and securing with cable ties.

**NOTE:**

Recommended spacing for cable ties is 100mm to 120mm. Position cable ties as shown.

# INSTALLATION INSTRUCTIONS - Welcome Light Kit

## INSTALLATION PROCEDURE: Passenger Side

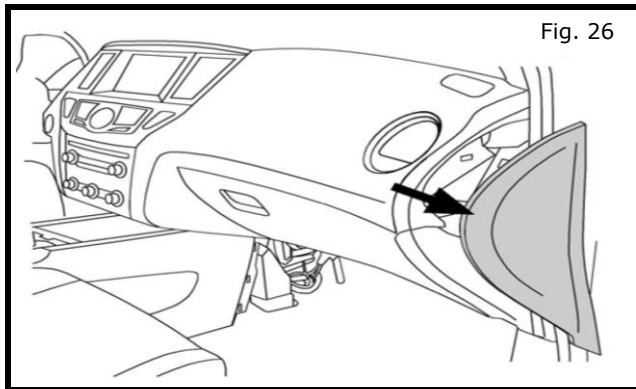

30) Removal of dash mask.

- a) Carefully pry off passenger side dash mask as shown.

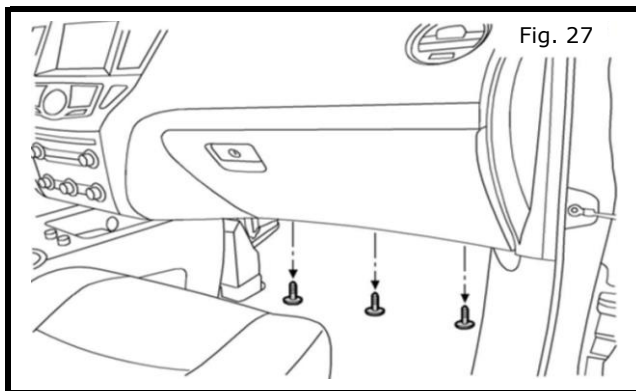

31) Removal of glovebox.

- a) Remove three (3) phillips head screws from underside of glovebox as shown.

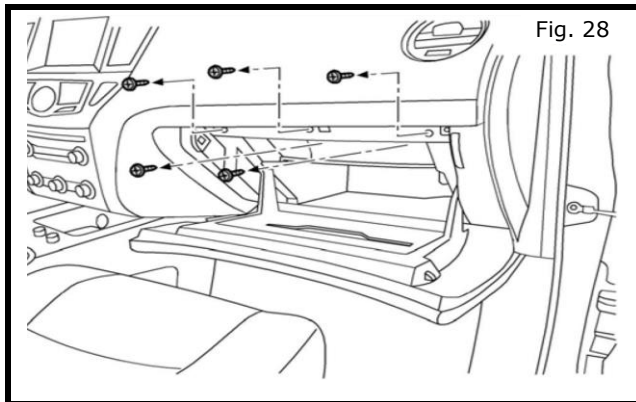

- b) Open glovebox door and remove the five (5) phillips head screws from inside glovebox compartment as shown.

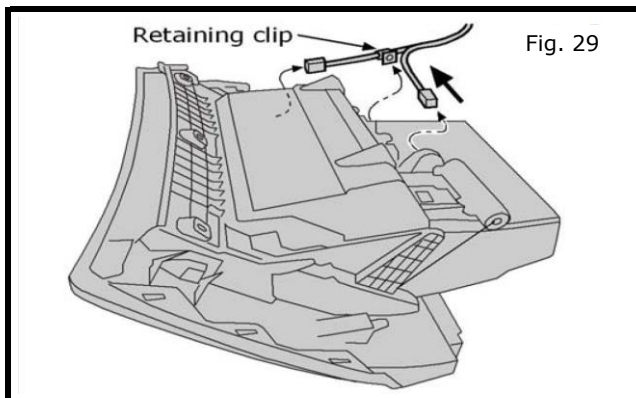

- c) Carefully pull glovebox assembly partially out, then gently detach clip and disconnect glovebox lamp as shown. Once fully removed, set glovebox assembly aside.

# INSTALLATION INSTRUCTIONS - Welcome Light Kit

## INSTALLATION

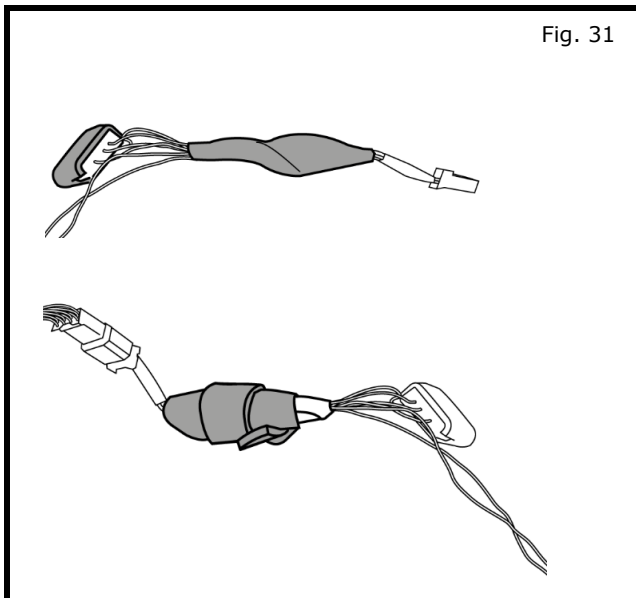
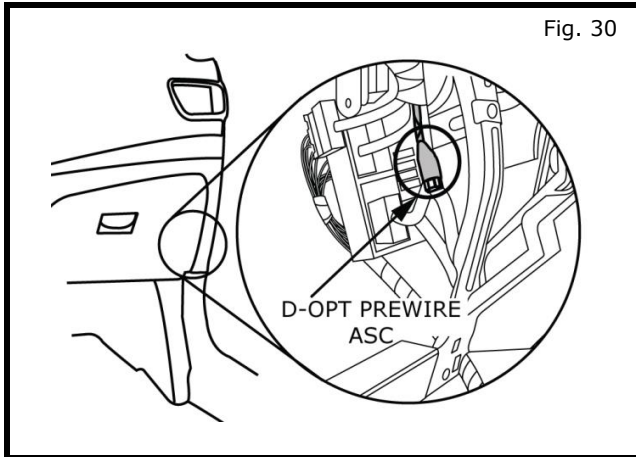

32) Prepare Passenger side Accessory connector:

a) Locate Passenger side D-Opt Connector plug. It will be taped to harness behind glovebox on right side of footwell as shown

b) A previously installed accessory may be present. If so, carefully remove the accessory connector harness from the accessory connector plug and remove all foam tape before posi-tapping.

It is recommended that all posi-tapping be completed before reattaching the accessory connector harness to the plug.

c) If there is not a previously installed accessory, remove the dummy plug in connector. See detail.

33) Wrap posi taps and any excess wiring from LED harness to the Accessory connector harness and with electrical tape as shown.

a) After wrapping in electrical tape cover bundle with foam tape.

b) Plug Accessory Connector Harness into vehicle connector plug on driver side.

**NOTE:**

**ACCESSORY SERVICE CONNECTOR NOT INCLUDED IN KIT. REFERENCE PART NUMBER 999Q9 AY001.**

**NOTE:**

**REFER TO ACCESSORY CONNECTOR DIAGRAM ON PAGE 16 and Mechanization B-2.**

# INSTALLATION INSTRUCTIONS - Welcome Light Kit

## ACCESSORY CONNECTOR MECHANIZATION: PASSENGER SIDE L.E.D. HARNESS ONLY

### ⚠ CAUTION

• This Accessory Service Connector is for use only with Genuine Nissan (or Infiniti) or Nissan (or Infiniti) approved accessories. Use of this connector with non Genuine Nissan (or Infiniti) or Nissan (or Infiniti) approved accessories or failure to follow the installation instructions for said connector being mentioned herein may result in damage to the accessory and/or your vehicle. Nissan (or Infiniti) is not liable for loss or damage due to improper installation or the installation of non Genuine or non approved accessories.

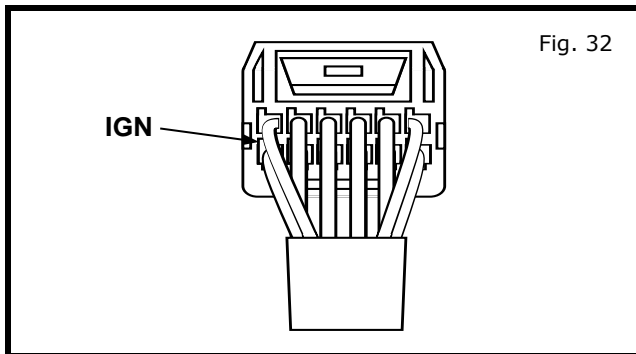

34) Locate ignition wire on Accessory Service Connector

#### NOTE:

- If there is already an Accessory Service Connector in the pass side read step 26-b), if not proceed to step 26-d.
- Pin location is referenced looking into face of connector.

#### NOTE:

Pin location in Fig. 33 is referenced looking into face of connector

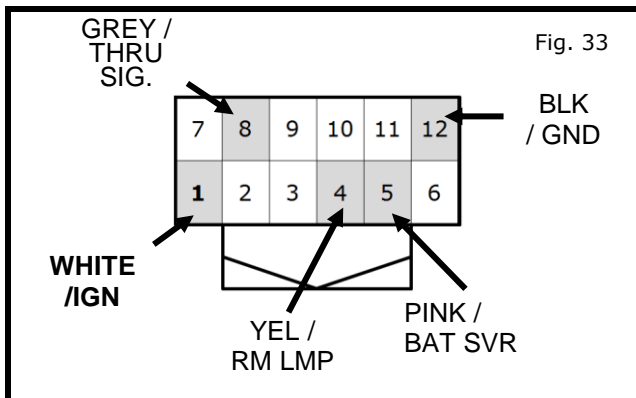

35) Use posi-taps to connect wiring as follows:

- Black** wire from Control Module to **Black** wire on Accessory Service Connector Harness.
- Purple** wire from Control Module to **Pink** wire on Accessory Service Connector Harness.
- Green** wire from Control Module to **White** wire on Accessory Service Connector Harness.
- White** wire from Control Module to **Yellow** wire on Accessory Service Connector Harness.
- Orange** wire from the Control Module to **Grey** wire on the Accessory Service Connector Harness.
- Black** wire from LED Harness to **Black** wire on the Controller Module Harness.
- Red** wire from LED Harness to **Orange** wire on Controller Module Harness.

Fig. 34

T99F6 4RA0A		
Pin	Label	Color
1	IGN	WHITE
2	BAT	RED
3	TL_LMP	PURPLE
4	RM_LMP	YELLOW
5	BATSVR	PINK
6	FR_DR_SW_RH	GREEN
7	FR_DR_SW_LH	LT GREEN
8	THRU SIGNAL 1	GREY
9	RR_DR_RH	BLUE
10	RR_DR_LH	LT BLUE
11	ACC	ORANGE
12	GND	BLACK



# INSTALLATION INSTRUCTIONS - Welcome Light Kit

## INSTALLATION PROCEDURE:

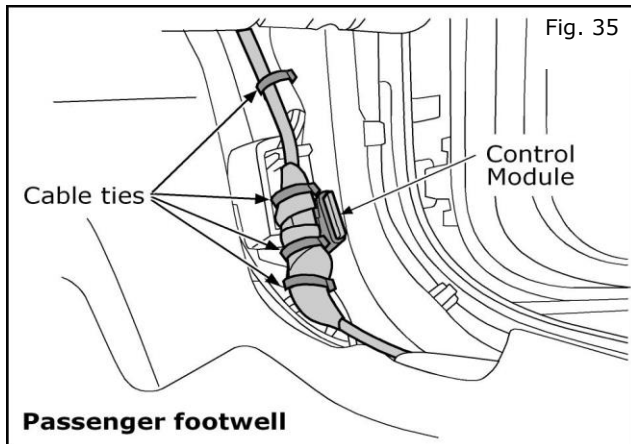

- 36) Plug Accessory Connector Harness into vehicle connector plug on passenger side.
- 37) Wrap Accessory Connector with foam tape. Use a cable tie to secure Control Module, connector and any excess bundled wiring to existing harness as shown.

### NOTE:

Refer to Posi-Tap steps on pages A1 -A3 for proper wire wrapping procedures.

### NOTE:

Reconnect Battery. Allow 3 minutes after positive terminal reconnect before separating or reconnecting any connectors.

### NOTE:

It is recommended to do a functional check of the system using check out procedures on page 22.

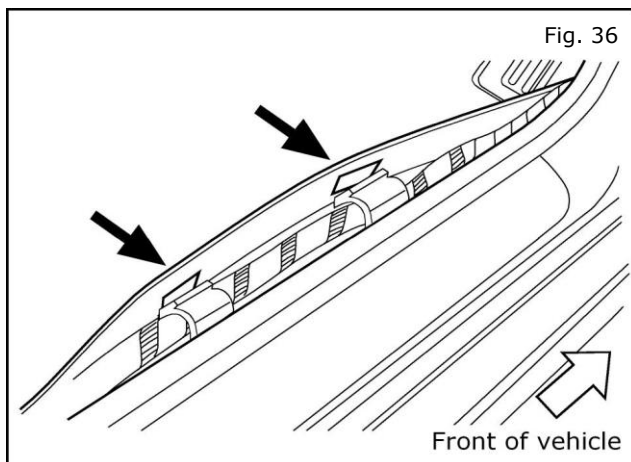

- 38) Re-seat metallic tape.
- 39) Reinstall carpet edge inside passenger side door sill.

### NOTE:

Be sure to align and secure the rectangular carpet holes with the carpet retaining features on the harness protectors.

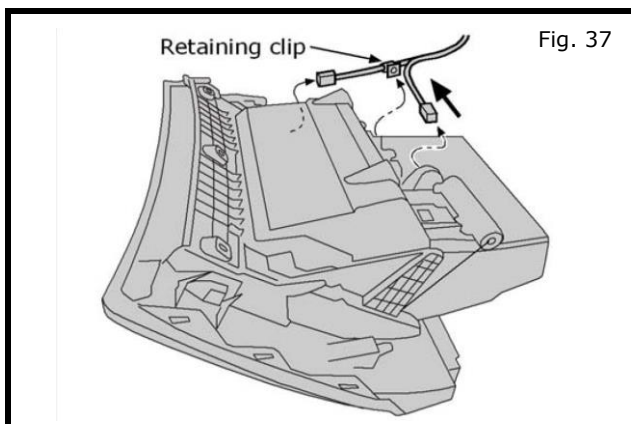

- 40) Reinstallation of glove box.
  - a) Reattach clip and reconnect glovebox lamp as shown.

# INSTALLATION INSTRUCTIONS - External Ground Lighting Kit

## INSTALLATION

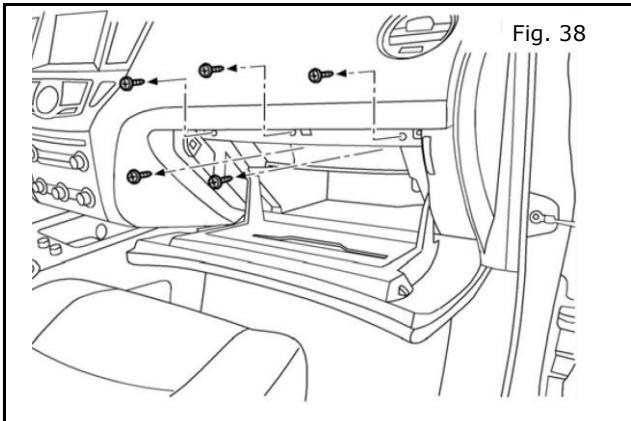

- b) Open glovebox door and reinstall five Phillips head screws from inside glovebox compartment as shown.

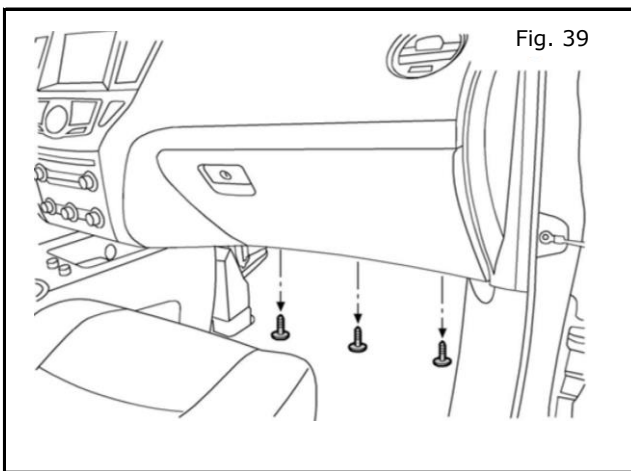

- c) Reinstall three Phillips head screws from underside of glovebox as shown.

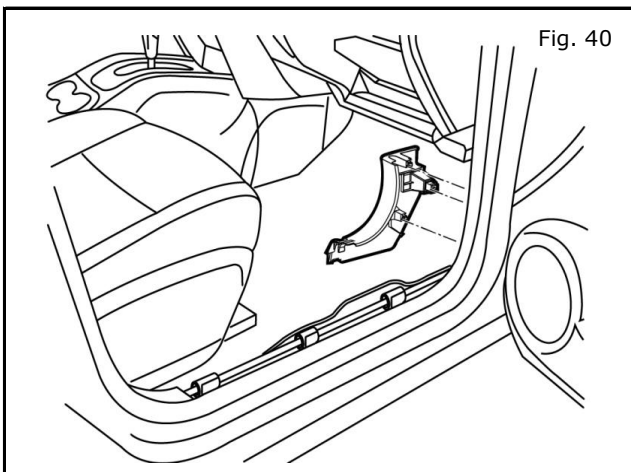

- 41) Reinstall the passenger side outer footwell trim panel and one fastener clip.

**NOTE:**

**Be sure clip is properly aligned. Be careful not to damage clip on panel during reinstallation.**

## INSTALLATION INSTRUCTIONS - Welcome Light Kit

### INSTALLATION

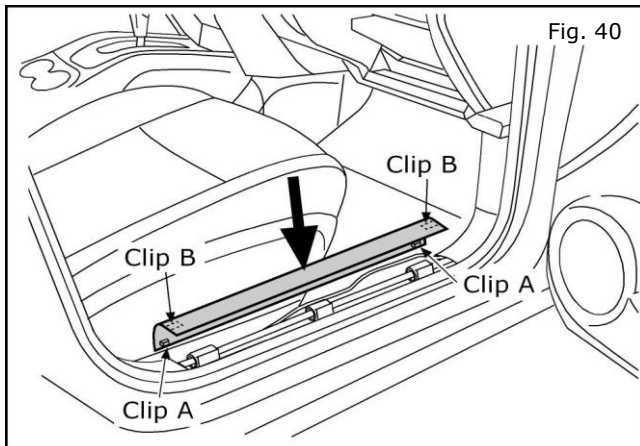

- 42) **Reinstall** the passenger side inner door sill trim panel.

**NOTE:**

**Be sure all clips are properly aligned. Be careful not to damage any clips on the panels during reinstallation**

- 43) **REPEAT STEPS 41 and 42 FOR DRIVER SIDE COMPONENTS.**

## INSTALLATION INSTRUCTIONS - Welcome Light Kit

### CHECK OUT

Inspect the vehicle for unfinished work.

Reinstall the battery negative terminal.

(1) Close all doors.

(2) Using the keyless entry fob, press the door unlock.

(3) Verify the security lighting turns on and off with the dome lamp in the car.

(4) Enter the car and press the door unlock and then start the car.

(5) Verify the security lamps turn off when the car starts.

(6) With the car running, shifter in park, open the door and Verify the lights remain off.

(7) Turn off the car and open the door again and verify the lights come on when the door is opened.

(8) Unlock the doors, wait and then lock the doors. The Security lighting should turn off quickly with the dome lamp.

(9) Verify the functionality of all electrical vehicle components where harnesses were accessed.

(10) Check and clear trouble codes (DTC).

(11) Check power window auto-up control. If it is not functioning properly, hold switch in "up" position for 5 seconds.

(12) If this vehicle will be returned to a dealer lot or showroom for an extended period of time, be sure the extended storage switch is placed in the "inventory" position. (Refer to section 9 - Vehicle Preparation)

**Note: When diagnosing electrical system problems, first disconnect the accessory connectors and note effect on system. Continue the investigation with the accessory connectors disconnected. Remember to reconnect the accessories when the investigation is complete.**

Posi-Tap™ is protected by patent # 5,228,875 5,695,369 5,868,589 6,692,313 Jap 2881414 Aus 708700 Tia 103534 Can 2204826 Mex 200626 Korea 477279 China Z197105562.9 & others pending.

## BILL OF MATERIALS

ITEM NO.	QTY	Part Name	Part Number
1	1	Welcome / Security Lighting Kit	T99F4 5CH1B
2	1	Control module	N/A Part of T99F4 5CH1B
3	1	LED PODS with Rugby Lens - RH	
4	1	LED PODS with Rugby Lens - LH	
5	1	Hardware Kit	
6	11	Grey foam rectangle 80mm x 30mm x 5mm thick - adhesive one side	
7	14	Cable ties 4" long - black	
8	7	Cable ties 11" long-black	
9	1	Cable ties 30" long-white	
10	9	Posi-tap connectors part No EX130-RR	
11	8	40mm x 20mm Adhesive Pads	
12	1	Q60, Altima Drill Template Strip	
13	1	Q50, Sentra, Rogue Drill Template Strip	
14	4	Alcohol Preparation Wipe	
15	4	Rubber Grommet GRM-0750P34C	
16	16	Push Pins	
17	2	Corrugated Flex Tube	
18	2	3M Butyl Gum	
19	1	Parts List / Replacement Template	
20	0	Q50/Q60 INSTALLATION INSTRUCTIONS (WEB)	T99F4 5CH1BII
21	0	Altima INSTALLATION INSTRUCTIONS (WEB)	999F4 U6000II
22	0	Maxima INSTALLATION INSTRUCTIONS (WEB)	T99F4 4RA5BII
23	0	Rogue INSTALLATION INSTRUCTIONS (WEB)	999F4 G6000II
24	0	Sentra INSTALLATION INSTRUCTIONS (WEB)	999F4 L6000II
25	2	Accessory Service Connector Harness (NOT INCLUDED IN KIT)	T99F6 4RA0A

# INSTALLATION INSTRUCTIONS

## INSTALLATION

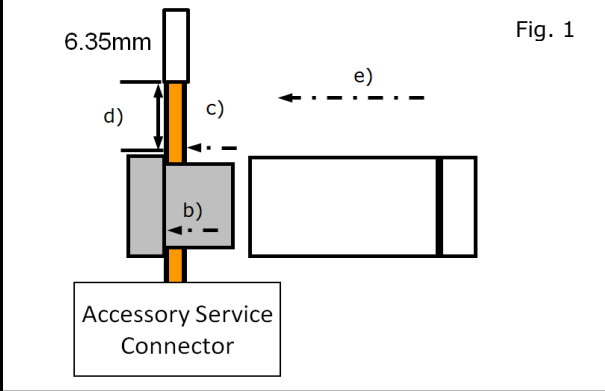

- 1) Posi-tapping an Accessory service wire (Fig. 1)
  - a) Identify and confirm correct wire in the Accessory Service Connector to be tapped.
  - b) Remove cap (slot side) from tap body.
  - c) Slide cap around single accessory wire.
  - d) Position cap  $\geq 6.35\text{mm}(0.25\text{in})$  away from the heat shrink end of Accessory Service Connector (measurement for first posi-tap installed on the circuit).
  - e) Tighten the tap **TIGHT** with finger pressure.
  - f) Tighten by another quarter turn.

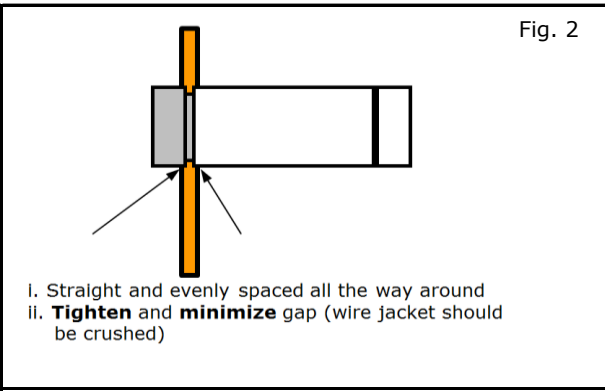

- 2) Inspecting the tap for correct installation (Fig. 2).
  - a) Pull on the wire lightly to ensure connection.
  - b) Inspect the tap to ensure correct installation.
  - c) Test the signal to ensure that it is working properly.

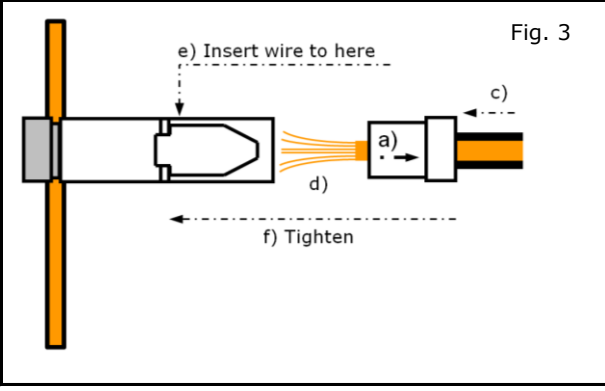

- 3) Tap accessory wire (Fig. 3).
  - a) Remove tap (non-pierce) side from tap.
  - b) Remove the protective stub from the wire.
  - c) Insert wire through the non-pierce side opening.
  - d) Spread the individual strands into fan shape.
  - e) Insert wire into the tap body and ensure that it is all the way in.
  - f) Tighten the tap **TIGHT** with finger pressure.
  - g) Tighten by another quarter turn.

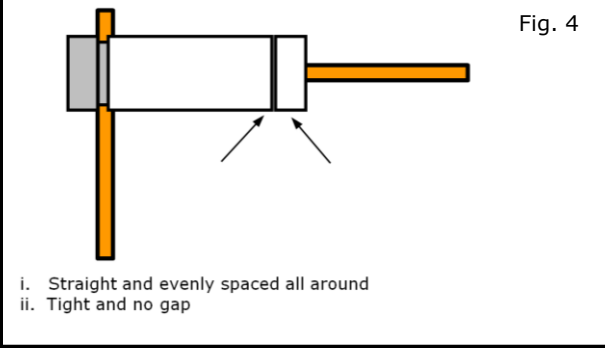

- 4) Confirm the tapped accessory wire.
  - a) Pull on the wire lightly to ensure connection.
  - b) Inspect the tap to ensure correct installation as shown in Fig. 4.

# INSTALLATION INSTRUCTIONS

## INSTALLATION

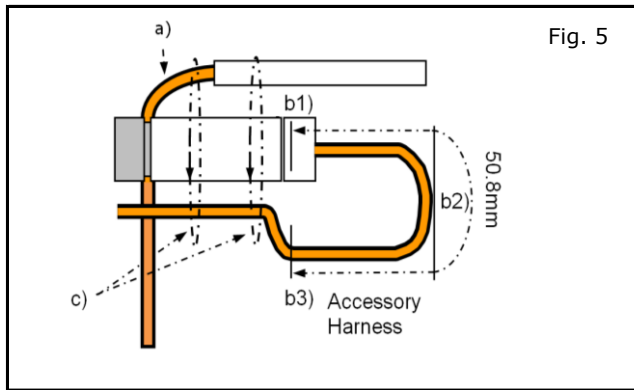

- 5) Forming strain relief loop - required (Fig. 5).
  - a) Gently bend end of pierced wire (where it exits cap) down towards body of posi-tap.
  - b) On tapped side wire; starting at point b1), measure 50mm to point b3). Make first bend of loop b2), half measured distance - 25mm, and up toward body of posi-tap, make second bend
  - c) Secure pierced wire on heat shrink side and tapped wire to body of tap with electrical tape ( $\geq 2$  revolutions).

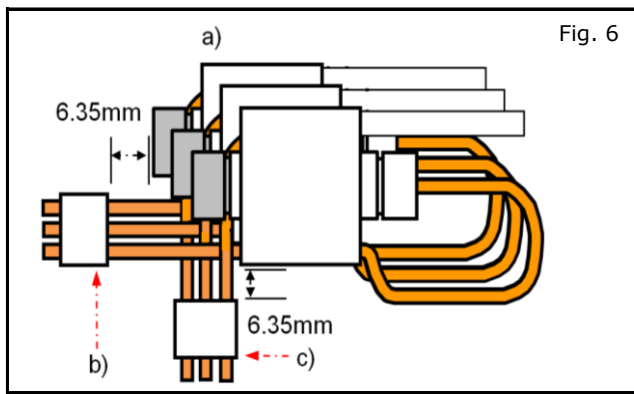

- 6) Securing multiple accessory taps (Fig. 6).
  - a) Tapped accessories (wires already secured to tap bodies) are stacked in a stagger on top of each other as shown in Fig a).
  - b) Secure tapped wires on connector side of posi-taps to each other with electrical tape ( $\geq 2$  revolutions) at a distance of  $\geq 6.35$ mm as shown in Fig b).
  - c) Pierced wires of posi-taps are secured to each other with electrical tape ( $\geq 2$  revolutions) at a distance of  $\geq 6.35$ mm (0.25in) as shown in Fig c).

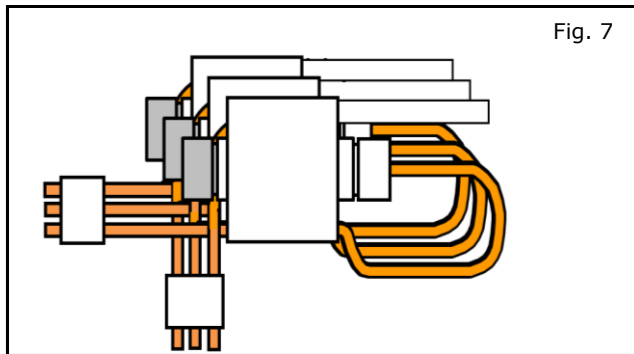

- 7) Securing multiple accessory taps (Fig. 7).
  - a) Make sure the accessory taps have been wrapped appropriately as detailed previously and as shown.

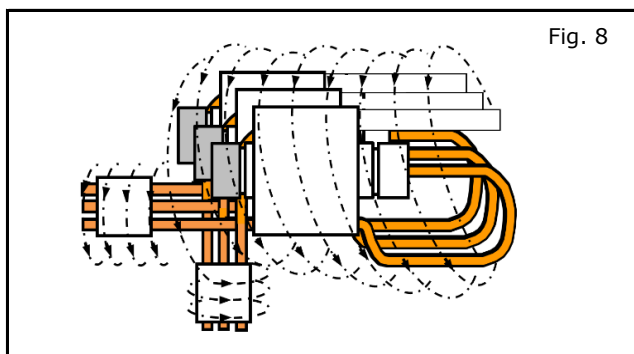

- 8) Securing multiple accessory taps.
  - a) Starting at heat shrink; firmly wrap posi-tap bundle with electrical tape or non-adhesive wire harness tape, making sure to overlap previous revolution.

**Note: If using non adhesive tape secure at the of wrap with electrical tape  $\geq 2$  revolutions.**

# INSTALLATION INSTRUCTIONS

## INSTALLATION

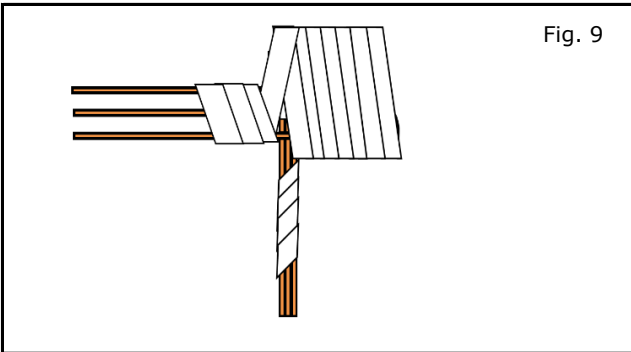

Fig. 9

- 9) Securing multiple accessory taps  
a) Make sure the finished wrap looks similar to Fig. 9.

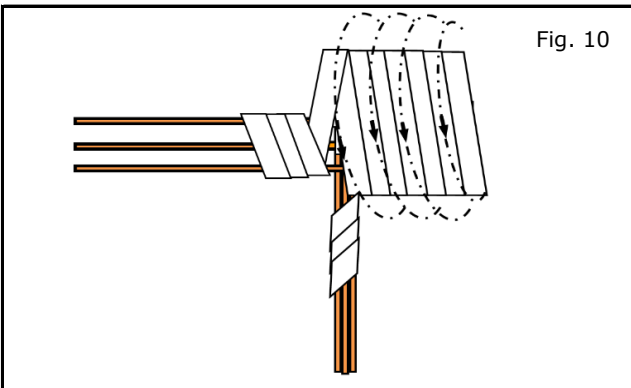

Fig. 10

- 10) Foam wrap for posi-tap bundle (foam strips)  
a) Wrap the posi-tap bundle with foam tape, following a pattern similar to the electrical tape, making the best use of foam strips provided.

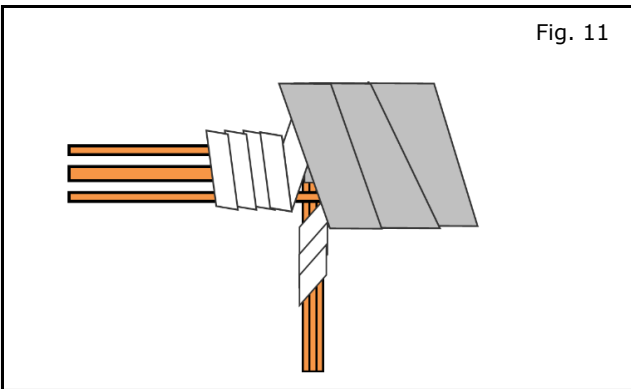

Fig. 11

- 11) Finished foam wrap for bundle (strips-top view)  
a) Make sure the finished wrap looks similar to Fig. 11.

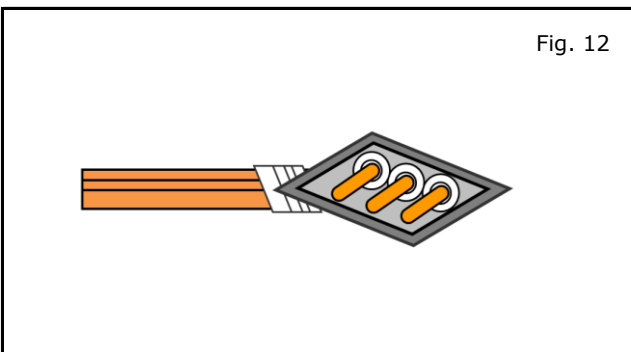

Fig. 12

- 12) Finished foam wrap for bundle (strips-side view)  
a) Make sure the finished wrap looks similar to what is shown in Fig. 12.



# INSTALLATION INSTRUCTIONS - Welcome Light Kit

## MECHANIZATION

### ACCY\_SER\_CONN

### DRIVER SIDE CONNECTOR

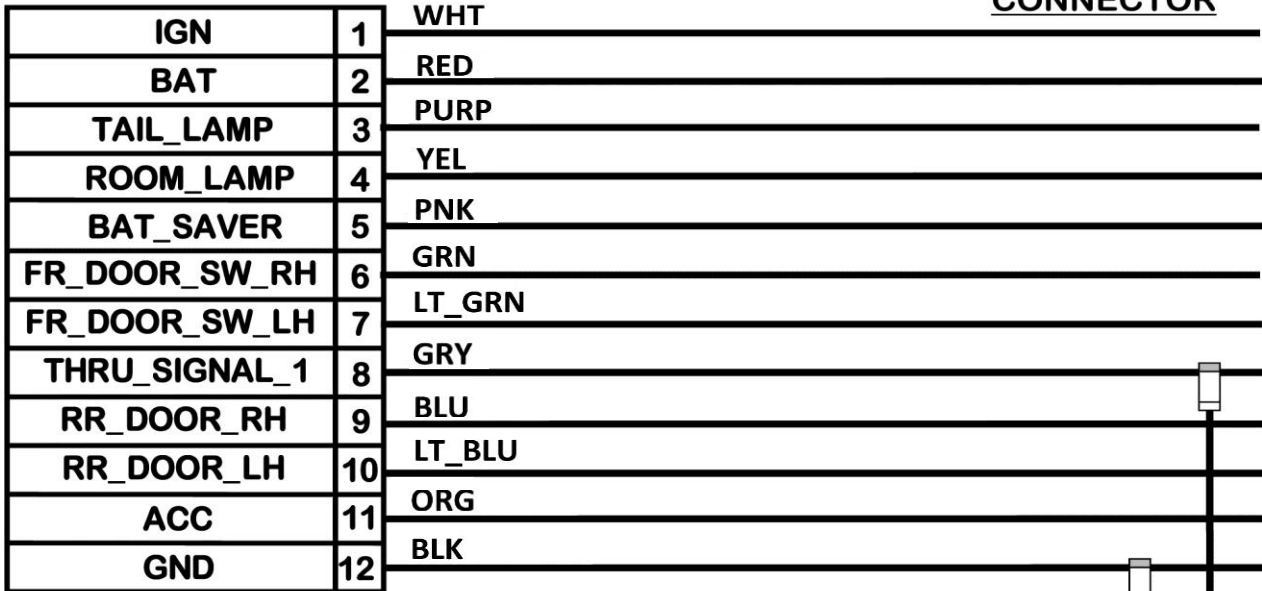

### TH12FW-NH

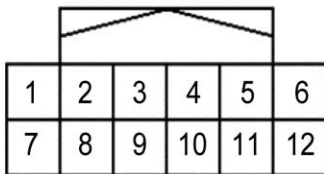

**Note:** Pin location is referenced looking into wire side of connector.

### LED MODULES LH

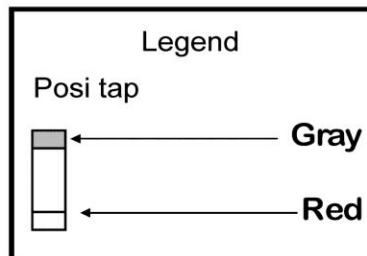
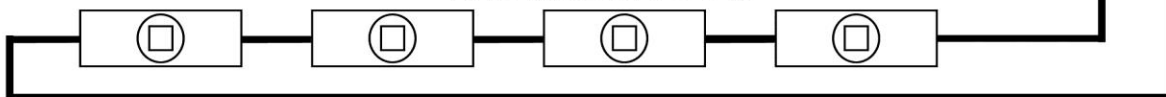

# INSTALLATION INSTRUCTIONS - Welcome Light Kit

## MECHANIZATION

### ACCY\_SER\_CONN

IGN	1
BAT	2
TAIL_LAMP	3
ROOM_LAMP	4
BAT_SAVER	5
FR_DOOR_SW_RH	6
FR_DOOR_SW_LH	7
THRU_SIGNAL_1	8
RR_DOOR_RH	9
RR_DOOR_LH	10
ACC	11
GND	12

### PASSENGER SIDE CONNECTOR

WHT
RED
PURP
YEL
PNK
GRN
LT_GRN
GRY
BLU
LT_BLU
ORG
BLK

**CONTROL  
MODULE**

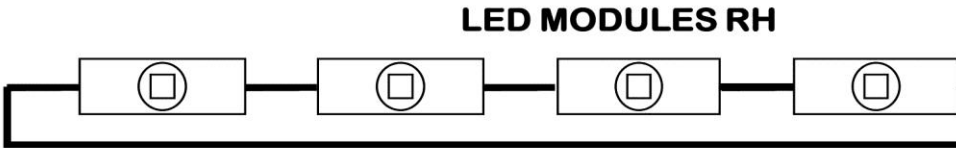

### TH12FW-NH

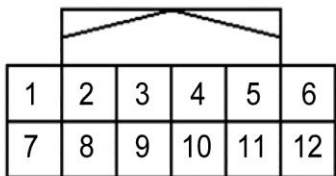

**Note: Pin location is referenced looking into wire side of connector.**

