



GENUINE PARTS

INSTALLATION INSTRUCTIONS

DESCRIPTION:	Splash Guard - Front Kit
APPLICATION:	LEAF
PART NUMBER:	T99J2 5SAxA (x Designates color)

KIT CONTENTS:

Item	Qty.	Part Description	Service Part Number
A	1	Splash Guard - Front Right	---
B	1	Splash Guard - Front Left	---
C	1	Installation Instruction Replacement Template	999V2 AW000
D	1	Installation Hardware Kit	---
E	2	• Phillips Screw M5 x 15mm	14-51 00841
F	4	• Phillips Screw M5 x 20mm	14-51 00891
G	2	• Clip	15-53 10501
H	2	• Spring Nut M5	12-41 00771

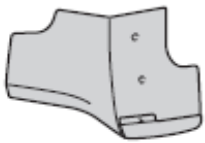

A

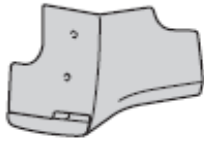

B



C



E



F



G



H

TOOLS REQUIRED:

- Phillips head short screwdriver
- Masking tape
- Clean, lint-free wiping cloth
- Mild soap / water mixture
- 90% or greater alcohol

PRE-INSTALLATION WARNINGS, CAUTIONS, CRITICAL STEPS, and NOTES:

- Dealer Installation Recommended. Instructions may refer to Service Manual.
- These instructions are for left side of vehicle; same procedure applies to right side.

CAUTION

- Install splash guards when ambient temperature is above 60°F (15°C).
- Do not wash or expose vehicle to wet environment for 24 hours after installing splash guards.

INSTALLATION PROCEDURE:

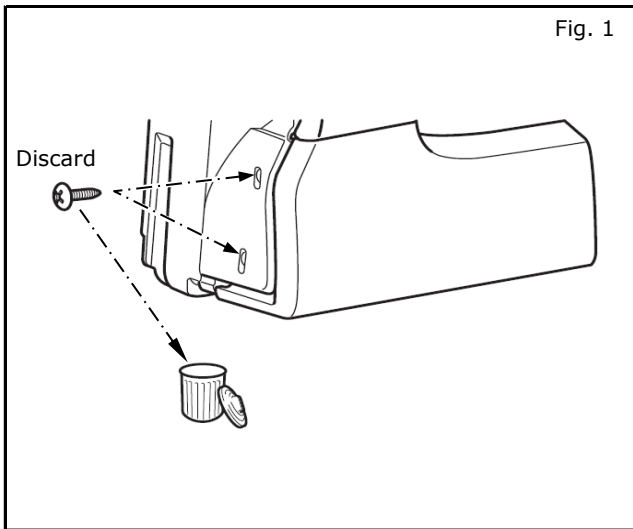

1) Remove screws from fender protector and discard.

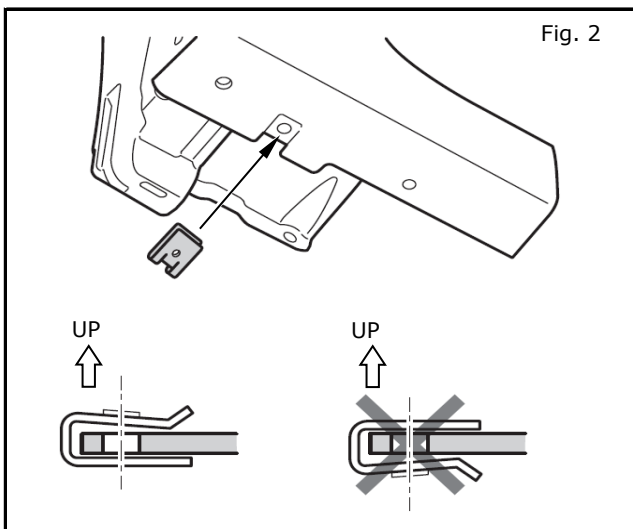

2) Install spring nut(H) to bottom of center mudguard.

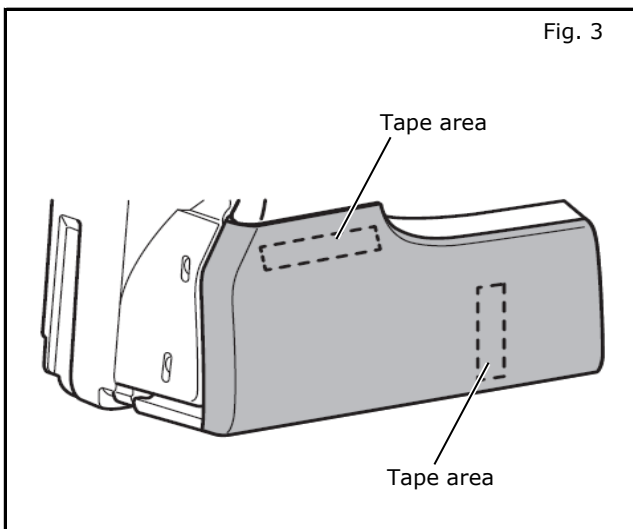

3) Clean installation surface (shaded area) with mild soap/ water mixture.

4) Using a clean, lint free cloth, wipe tape area with 90% or greater alcohol.

INSTALLATION PROCEDURE:

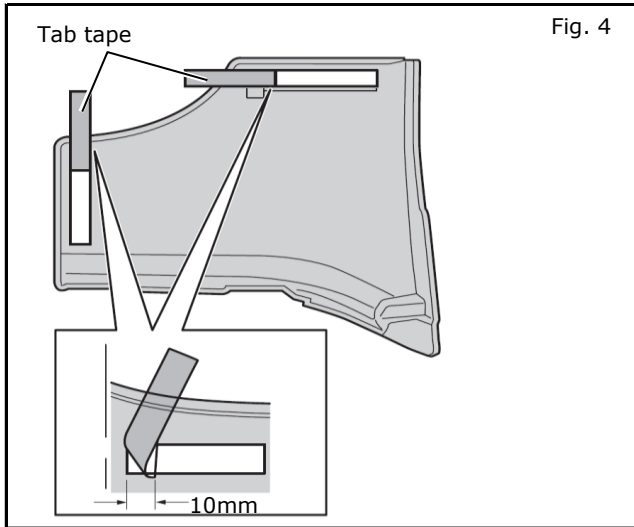

- 5) Peel back tape liners 10mm, and place back down in original position.

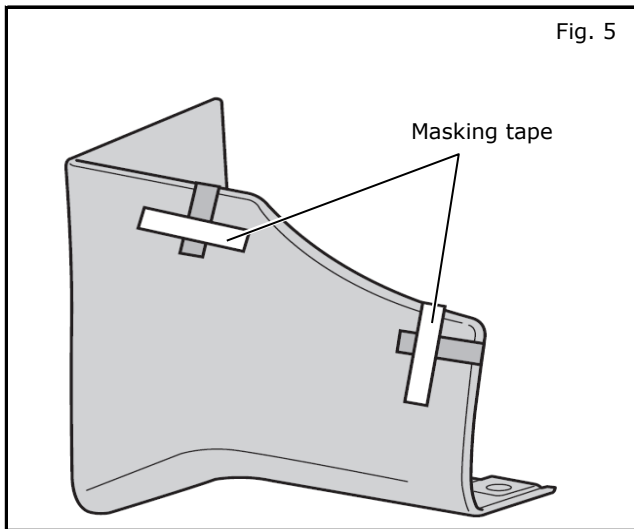

- 6) Fold tape liner pull tabs onto front splash guard exterior surface, and apply masking tape to ensure that pull tabs will be accessible.

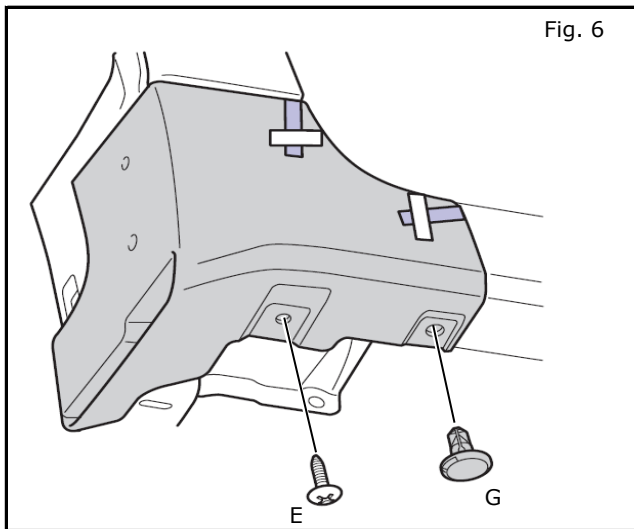

- 7) Align front splash guard to vehicle, and loosely install phillips screws(E), making sure pull tabs are exposed.
- 8) Install clip(G).

INSTALLATION PROCEDURE:

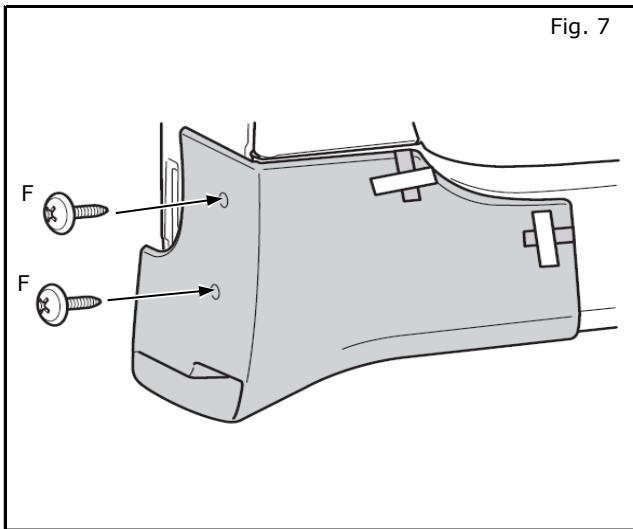

- 9) Align front splash guard to vehicle, and loosely install phillips screws(F), making sure pull tabs are exposed.

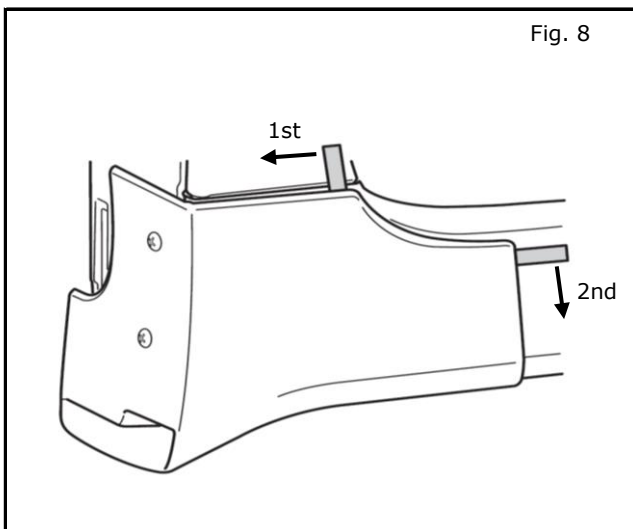

- 10) Remove tape liners by slowly pulling in directions shown by arrows.

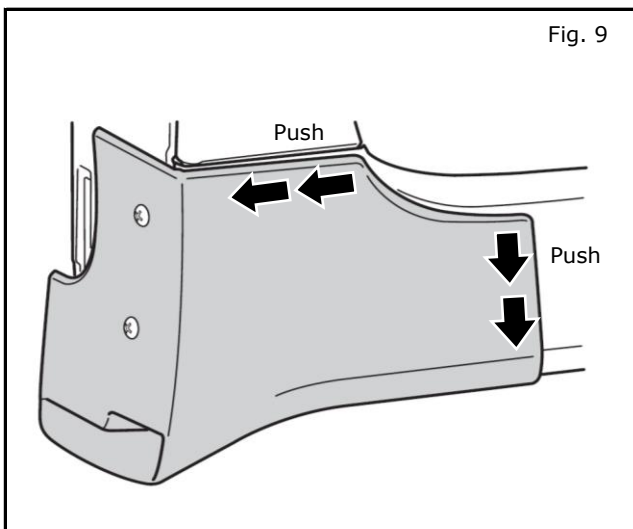

- 11) Apply at least 15lb/in² (1kg/cm²) of pressure to front splash guard to ensure that tape is attached.

NOTE:

Use roller or apply pressure by hand with rag. Apply minimum of 15lb/in² (1kg/cm²) of pressure along all lengths of tape.

INSTALLATION PROCEDURE:

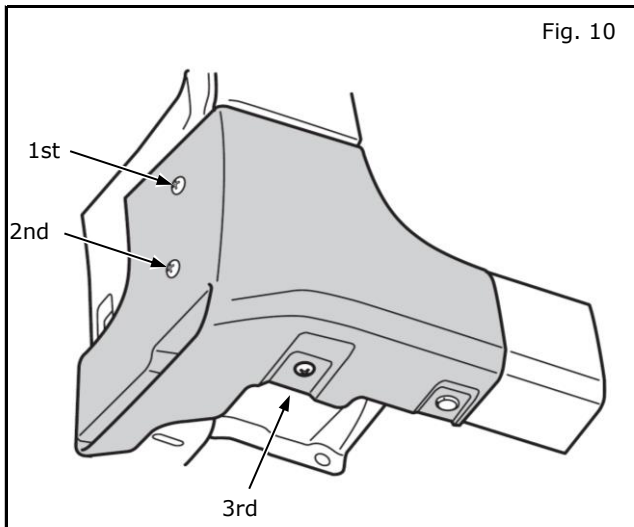

12) Tighten phillips screws in sequence shown.

NOTE:

Do not over tighten screws. Reference tightening torque 3.8~4.4 N-m (33.6~38.9 lb-in).

ACCESSORY CHECK:

- Check all torque values.
- Clean vehicle surface near installation areas.
- Check gap.

FINAL INSPECTION:

- Verify exterior is not damaged.