



GENUINE PARTS

INSTALLATION INSTRUCTIONS

DESCRIPTION: Chrome Rear Bumper Protector

APPLICATION: Altima

PART NUMBER: T99B1 6CA0A

KIT CONTENTS:

Item	Qty.	Part Description
A	1	Rear Bumper Protector
B	2	Spacer Block
C	2	Alcohol Prep Pads
D	1	Installation Instruction Replacement Template

TOOLS REQUIRED:

- Clean Lint Free Cloth
- Masking Tape

PRE-INSTALLATION WARNINGS, CAUTIONS, CRITICAL STEPS, and NOTES:

- Dealer installation recommended.

CAUTION

- Please wash vehicle with soap and water prior to installing bumper protector.
- Do not wash vehicle for 24 hours after installing bumper protector. Washing vehicle less than 24 hours after installing bumper protector can cause it to not adhere properly.
- Install bumper protector only when part and vehicle temperature are between 16°C - 43°C (60°F - 110°F).
- Failure to clean mounting surface properly can cause poor adhesion between bumper protector and vehicle.
- Failure to apply enough pressure to all tape lengths can cause bumper protector to not adhere properly.
- To allow time for adhesive to cure, maintain vehicle temperature between 16°C - 43°C (60°F - 110°F) for a minimum of 2 hours after installing bumper protector.

INSTALLATION PROCEDURE:

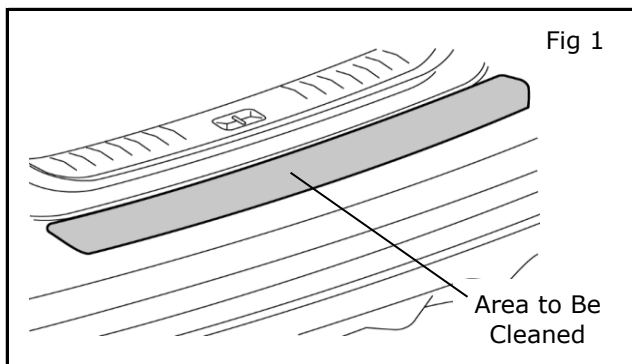

- 1) Open trunk lid.
- 2) Clean attachment area of vehicle (shaded area).
 - a) Wash with soap and water to remove any dirt or debris. Allow time to dry.
 - b) Cleanse with alcohol prep pads. Allow time to dry.

NOTE:

Failure to clean mounting surface properly can cause poor adhesion between bumper protector and vehicle.

INSTALLATION PROCEDURE:

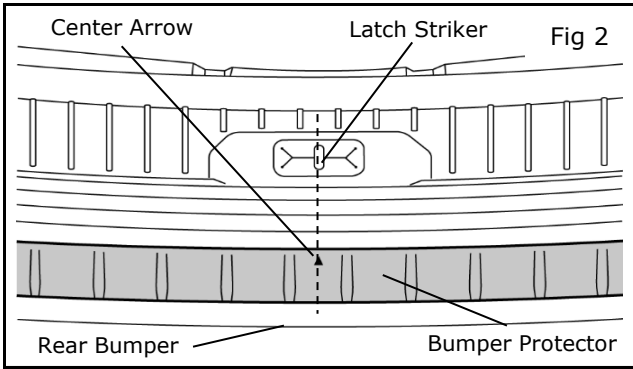

- 3) Dry fit bumper protector on vehicle. Align bumper protector center arrow with trunk lid latch striker.

NOTE:

Do not remove tape liners.

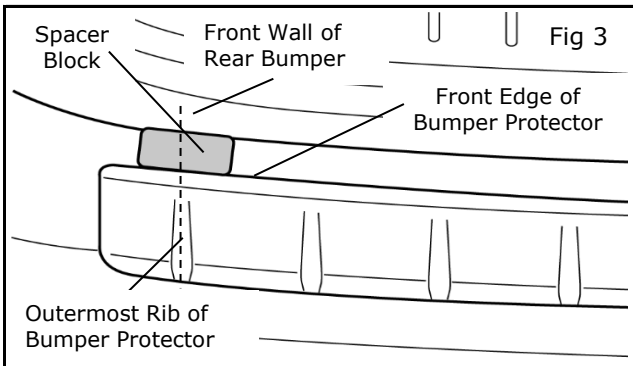

- 4) On left-hand side of bumper protector, position spacer block between front wall of rear bumper and front edge of bumper protector while centering it with outermost rib of part. Repeat on righthand side of part.

NOTE:

Spacer blocks must have snug fit between front wall of rear bumper and front edge of bumper protector.

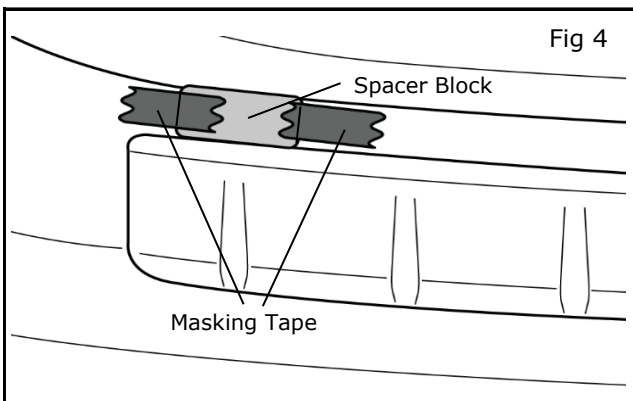

- 5) Secure spacer blocks to rear bumper with masking tape.

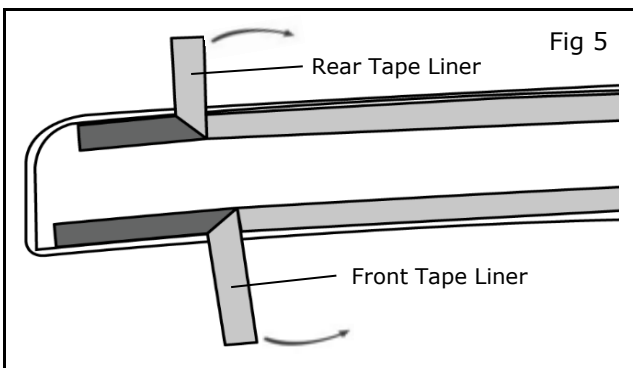

- 6) Prepare tape.
- a) Remove bumper protector.
 - b) Peel back rear tape liners approximately 30 mm (1¼ in).
 - c) Peel back front tape liners approximately 50 mm (2 in).
 - d) Fold back all tape liners.

INSTALLATION PROCEDURE:

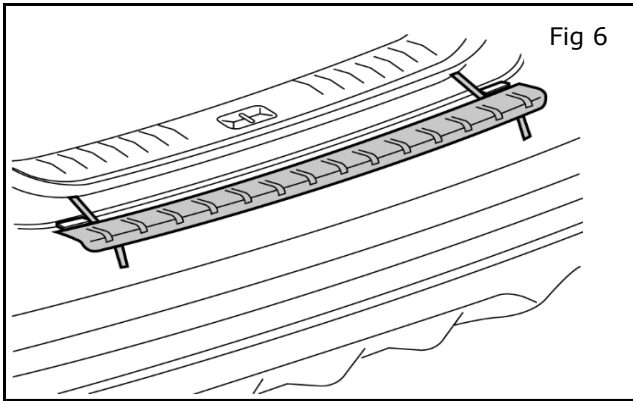

- 7) Realign bumper protector to trunk lid latch striker and spacer blocks, and apply gentle pressure to lightly tack both ends of part to vehicle.

NOTE:

Do not apply firm pressure.

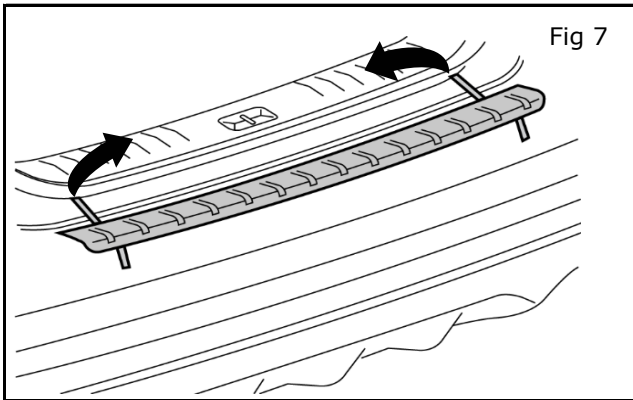

- 8) Confirm center arrow alignment, tight fit to spacer blocks, and consistent side gaps between bumper protector and rear bumper. If necessary, untack bumper protector and repeat.

- 9) Remove spacer blocks.

- 10) Remove front tape liners by slowly pulling towards center.

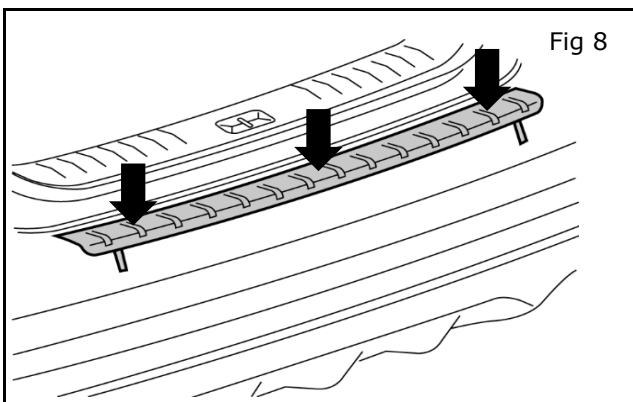

- 11) Using clean lint free cloth, apply 1 kg/cm^2 (15 lb/in^2) of firm pressure along front tape path. Start from center and work outward in one direction. Repeat in opposite direction.

INSTALLATION PROCEDURE:

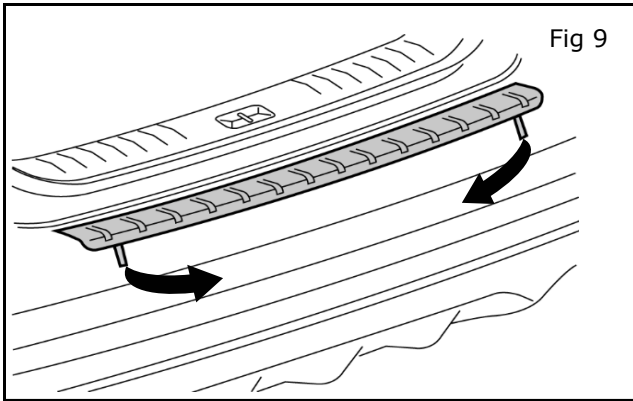

- 12) Remove rear tape liners by slowly pulling towards center.

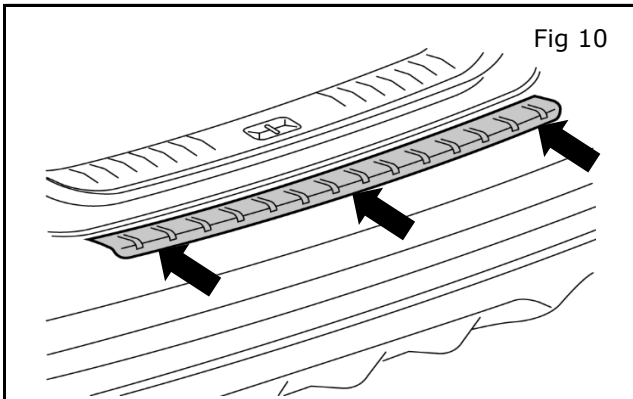

- 13) Using clean lint free cloth, apply 1 kg/cm^2 (15 lb/in^2) of firm pressure along rear tape path. Start from center and work outward in one direction. Repeat in opposite direction.

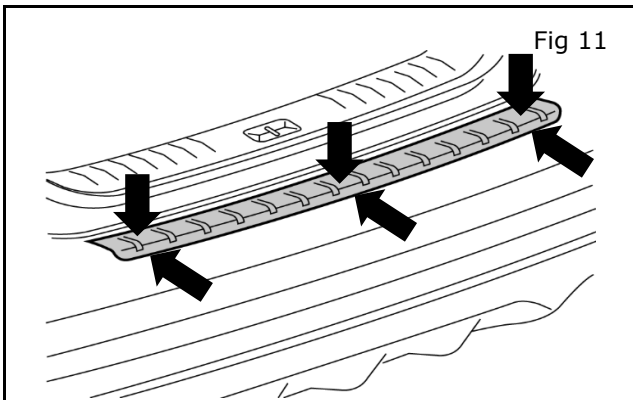

- 14) To ensure adequate adhesion, reapply 1 kg/cm^2 (15 lb/in^2) of firm pressure across entire bumper protector.

NOTE:

Failure to apply enough pressure to all tape lengths may cause bumper protector to not adhere properly.

- 15) Remove and discard protective film.
- 16) Close trunk lid.
- 17) Maintain vehicle temperature between 16°C - 43°C (60°F - 110°F) for a minimum of 2 hours, and do not expose vehicle to moisture for a minimum of 24 hours. This will allow time for tape to cure.