



GENUINE PARTS

INSTALLATION INSTRUCTIONS

DESCRIPTION: Accent Lighting Kit

APPLICATION: Maxima

PART NUMBER(S) T99F3 4RA2B, Accent Lighting Kit

REQUIRED FOR

INSTALLATION: T99F6 4RA0A , Accessory Service Connector - not included in kit above

KIT CONTENTS: Interior Accent Lighting

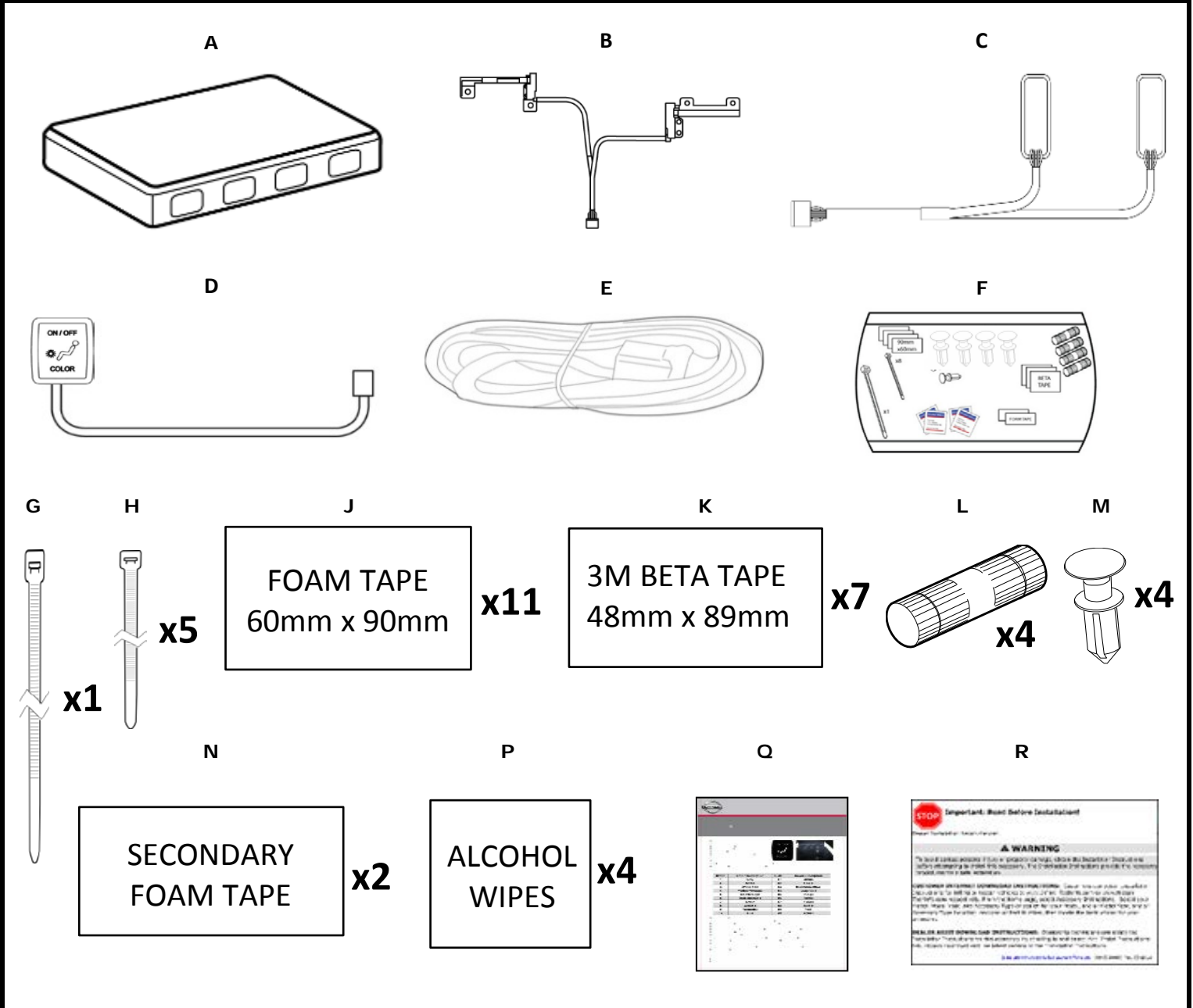

ADDITIONAL SERVICE PARTS NOT INCLUDED IN KIT ABOVE :

Item	Qty.	Part Description	Service Part Number
AAA	1	Accessory Service Connector	T99F6 4RA0A



AAA

PART NUMBER(S) T99F3 4RA2B, Accent Lighting Kit
REQUIRED FOR
INSTALLATION: T99F6 4RA0A , Accessory Service Connector - not included in kit above

KIT CONTENTS:

Item	Qty.	Part Description	Service Part Number
A	1	Control Module	Not Serviceable- Parts of kit- T99F6 4RA0A
B	1	Footwell Lights and Harness Assembly	
C	1	Cup Holder Lights and Harness Assembly	
D	1	2-Button Color Selection Switch and harness	
E	1	Vehicle Interface Harness	
F	1	Hardware Kit	
G	5	Wire Tie, 8 Inch	
H	1	Wire Tie, 30 Inch	
J	11	Foam Tapes, 60x90MM	
K	7	3M Beta Tape 5073, 48x89MM	
L	4	Posi-Taps	
M	4	Push Pin Clip, Ø5.2MM	
N	2	Secondary Foam Tape	
P	4	Alcohol Wipe	
Q	1	Quick Reference Card	
R	1	Installation Instruction Website Address	

TOOLS REQUIRED:

- Trim Stick (Nylon)
- #2 Phillips Screw Driver
- Side Cut Pliers
- DeBurring Tool
- Ratchet, 1/4" Driver
- (Awl) Center Hole Punch
- Switch Location Templates
- 90 Degree Small Drill
- Drill Bit Stop
- Socket, 10mm
- 1/8" , 3/8", & 7/16" pilot point drill bits
- Step Drill
- Electrical Tape
- Torque Wrench, 1/4" Driver

INSTALLATION CAUTIONS:



CAUTION

- Dealer installation recommended. Instructions may refer to Service Manual.
- Please read this instruction carefully before installing this product for correct installation.
- Please DO NOT use or install part in ways other than what is described.
- Always use floor, seat and steering wheel protection.
- Parts utilizing adhesion as method of attachment are to be installed at surface temperature of 15-38° C
- Posi-Tap™ instructions must be specifically followed as described in Appendix A.
- Apply masking tape as needed to protect areas that may be scratched or damaged by tools.
- Always remove vehicle parts in sequence directed. Improper procedure can damage parts.
- Take care not to scratch or damage any component during removal or re-installation process.
- Trim pieces found to have witness marks or broken clips ARE NOT to be reinstalled.
- Store removed parts in safe manner.
- If problem occurs during installation, please contact Nissan dealer where product was purchased.

SECTION 1 - OVERVIEW

1.1) SYSTEM

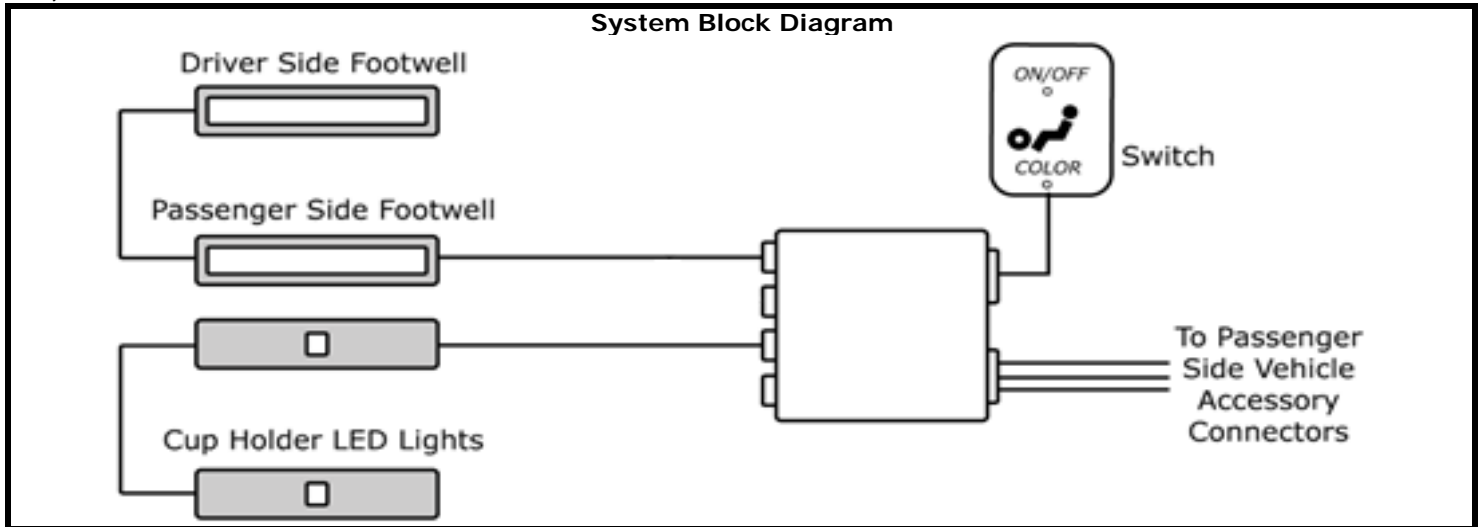

1.2) VEHICLE

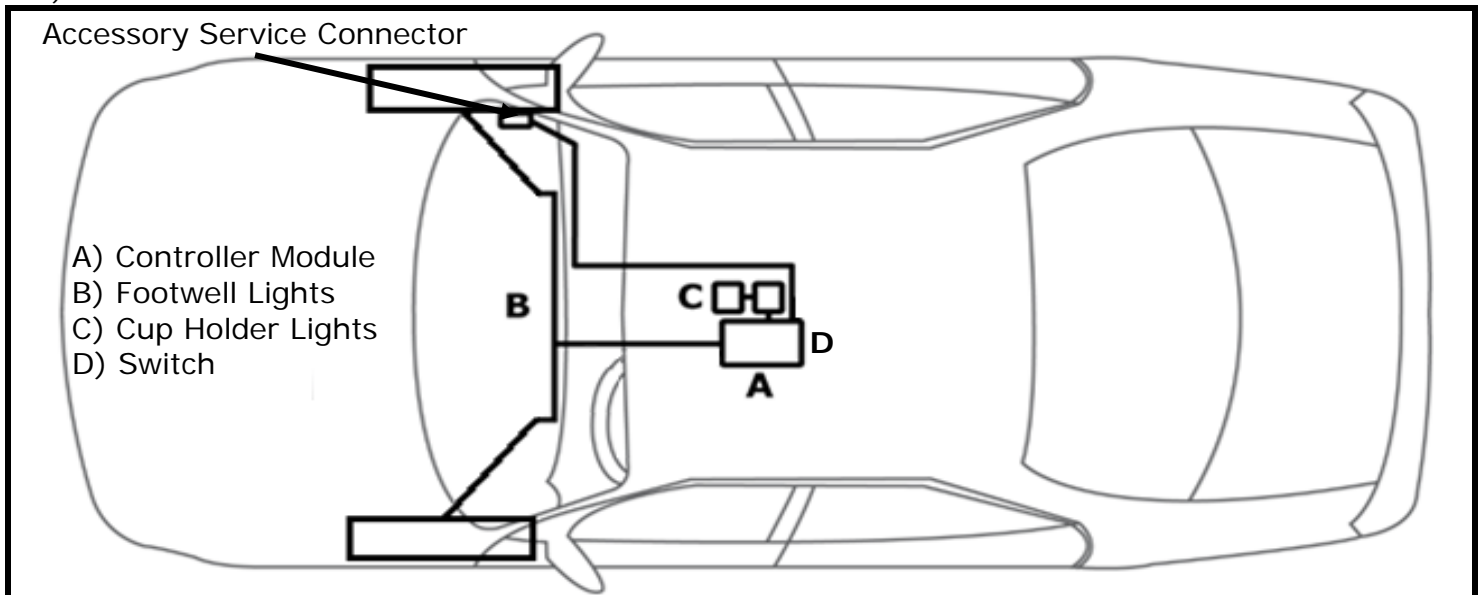

1.3) D-OPT CONNECTOR LOCATION

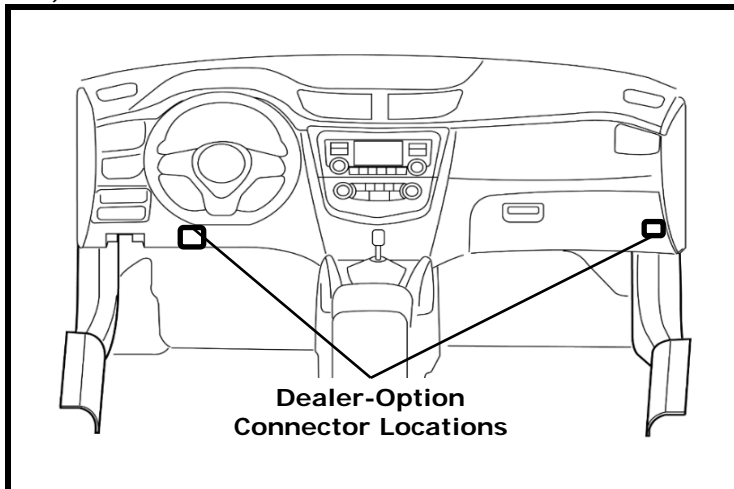



CAUTION

- Always confirm the ignition is in the "OFF" position before changing the E.S.S. position.
- If E.S.S. is not in Customer Mode, there will be loss of normal vehicle operation, preventing accessory function check.

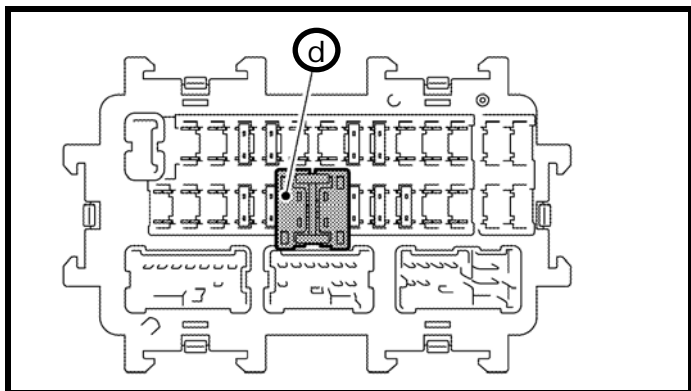

- 2.1) Check Extended Storage Switch Position
- a) Put shift lever in "P" position for A/T and CVT or "1st" for M/T .
 - b) Apply park brake.
 - c) Place ignition in "OFF" mode.
 - d) Locate Extended Storage Switch in cabin fuse block as shown.
 - e) Confirm Extended Storage Switch is in "Customer" (In/Engaged) position.
 - f) If ESS is not In/Engaged, then proceed to step 2.2 .

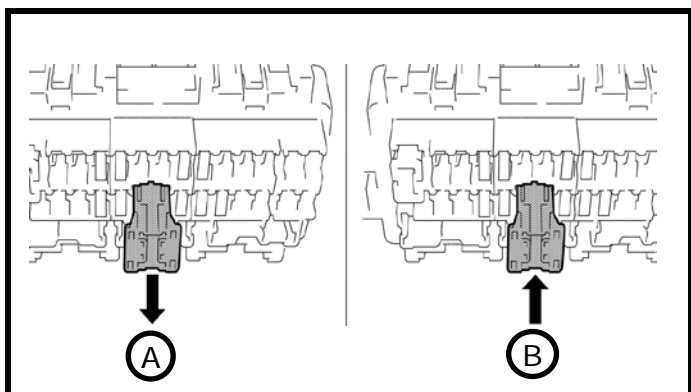

- 2.2) Changing ESS Position
- a) To disengage Customer Mode, pull out in (A) direction as shown.
 - b) To engage Customer Mode, press in (B) direction as shown.

Condition	Switch Position	Note
Vehicle is delivered to the dealer	Transit (OUT)	
Vehicle is being stored at the dealer	Transit (OUT)	
Vehicle is delivered to customer	Customer (IN)	

- 2.3) Record Customer Presets
- a) Place ignition in "ON" mode.
 - b) Record the customer radio presets and other presets as required.

Preset	1	2	3	4	5	6	7	8	9	10

- c) Place ignition in "OFF" mode.

SECTION 2 - VEHICLE PREPARATION

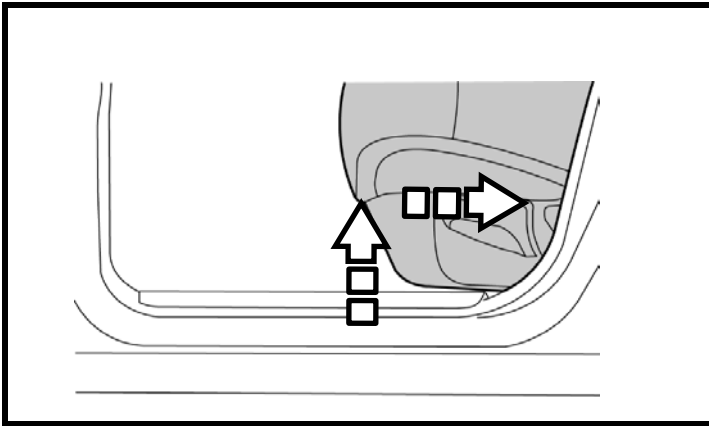

- 2.4) Move Seats
- Move both front seats to full upward and rearward position.

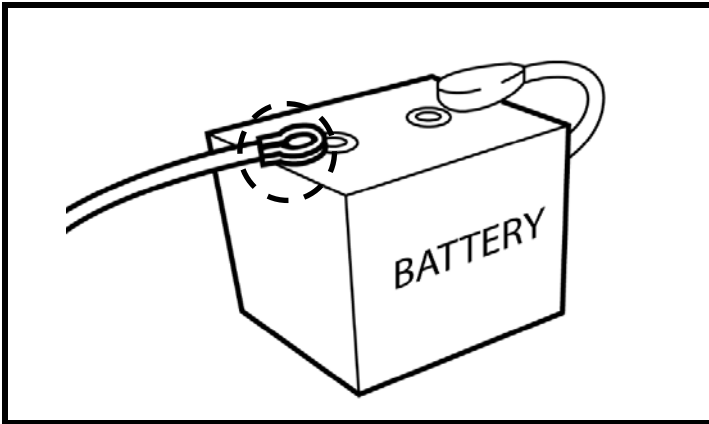

- 2.5) Disconnect battery terminal
- Locate negative battery terminal
 - Loosen nut with 10mm socket.

Battery Terminal Nut



CAUTION

- Allow 3 min after key off with doors closed for vehicle power to time out.

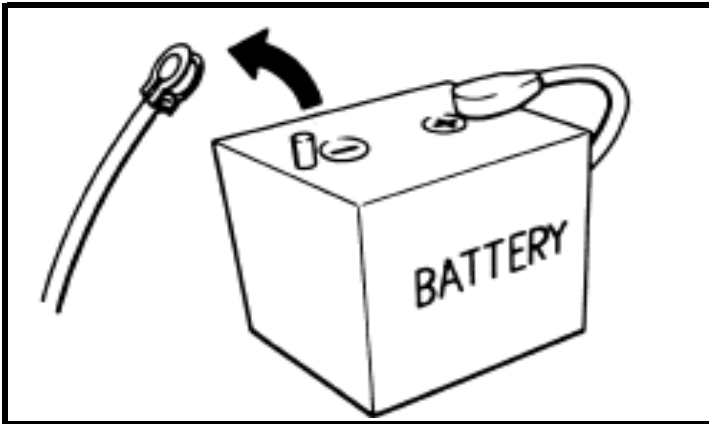

- 2.6) Disconnect battery terminal
- Lift negative battery terminal off stud.
 - Isolate negative battery terminal.



CAUTION

- Allow 3 min after negative terminal disconnect before separating any electrical connectors.

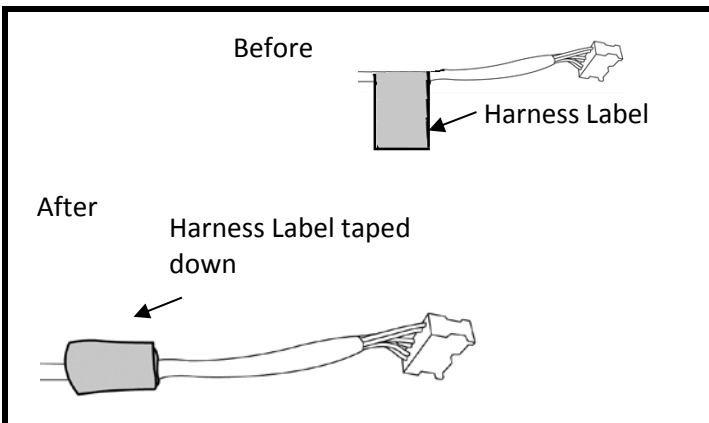

- 2.7) Harness preparation
- To prevent squeak and rattle, wrap label on harness around harness and secure down with tape.

SECTION 3 - TRIM REMOVAL (FRONT LEFT HAND)

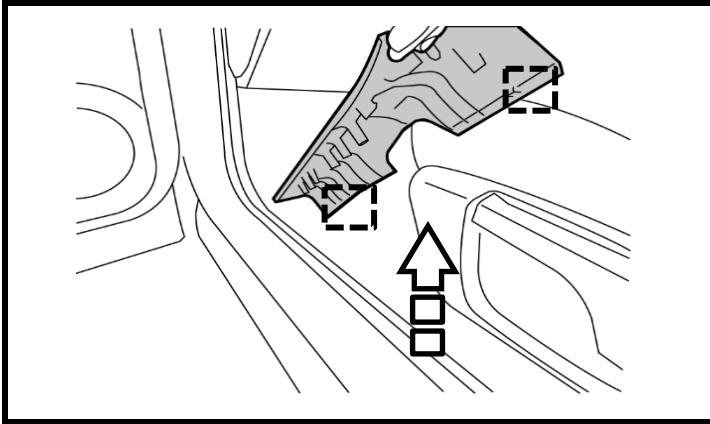

- 3.1) Remove LH Trim
 - a) Disengage lower trim clips by pulling toward interior.
 - b) Lift sill plate up and out, as shown.

Trim Clip

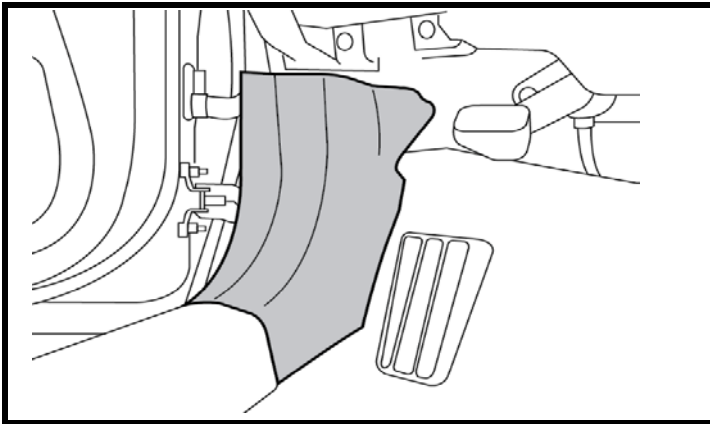

- 3.2) Remove LH Trim
 - a) Locate LH lower kick trim.

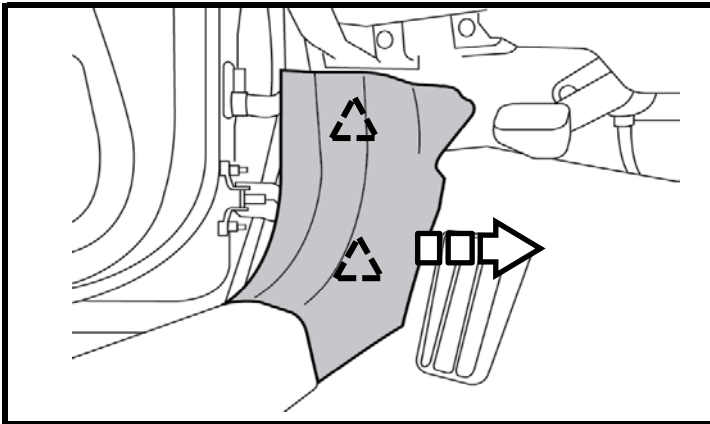

- 3.3) Remove LH Trim
 - a) Disengage lower kick trim pawl by pulling toward interior of vehicle, as shown.

Pawl



SECTION 3 - TRIM REMOVAL (FRONT RIGHT HAND)

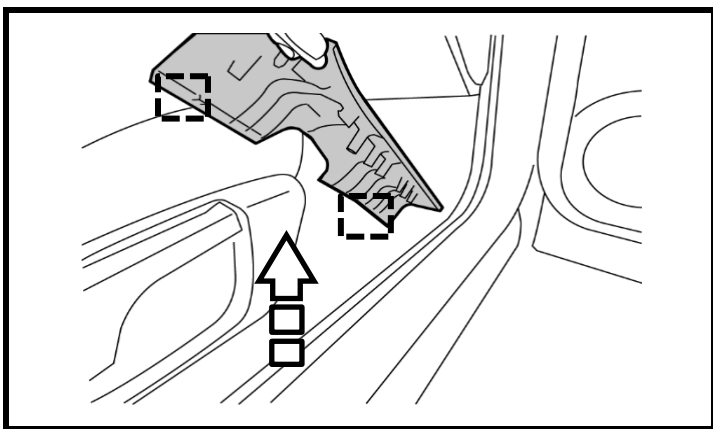

- 3.4) Remove RH Trim
- a) Disengage lower trim clips by pulling toward interior.
 - b) Lift sill plate up and out, as shown.

Trim Clip

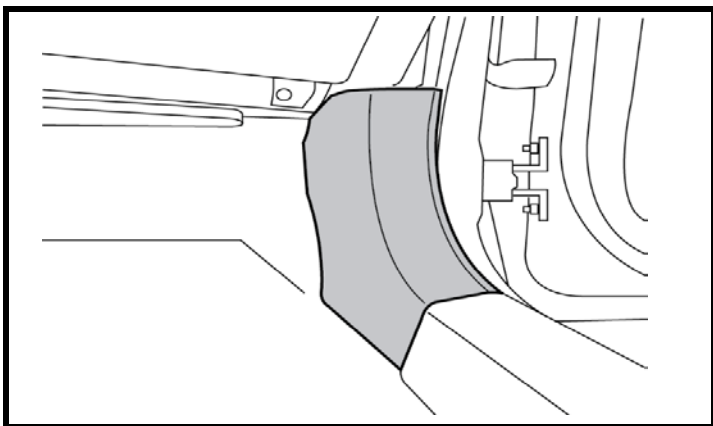

- 3.5) Remove RH Trim
- a) Locate RH lower kick trim.

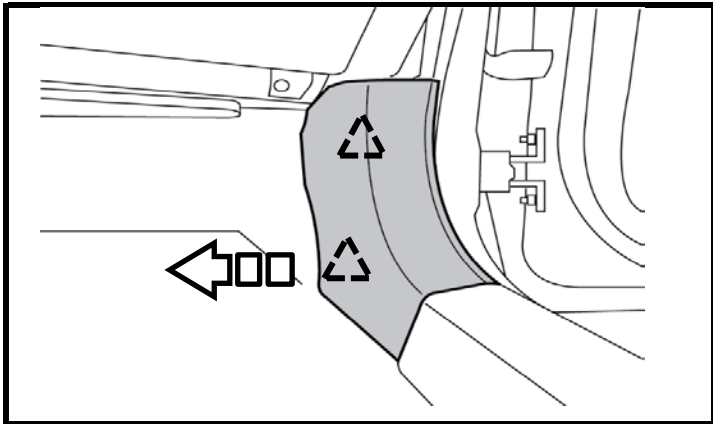

- 3.6) Remove RH Trim
- a) Disengage lower kick trim pawl by pulling toward interior of vehicle, as shown.

Pawl



SECTION 3 - TRIM REMOVAL (FRONT LEFT AND RIGHT HAND)

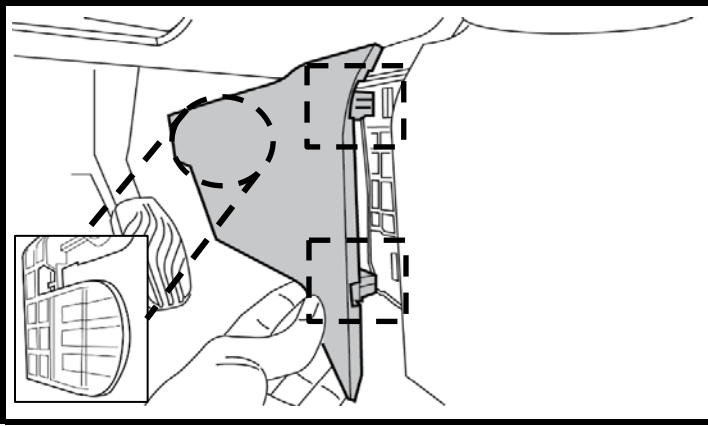

- 3.7) Remove LH Trim
- Carefully pry out center footwell panel from driver side of center console.
 - Pull out at center and slide to rear.
 - Ensure front retainer clip stays with panel

Trim Clip

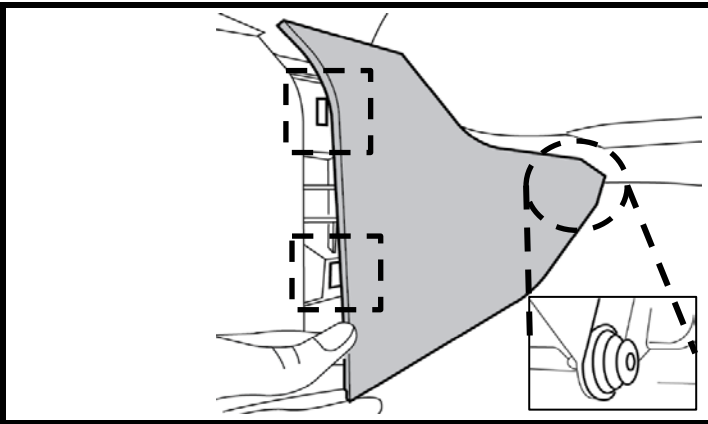

- 3.8) Remove RH Trim
- Carefully pry out center footwell panel from passenger side of center console.
 - Pull out at center and slide to rear.
 - Ensure front retainer clip stays with panel

Trim Clip

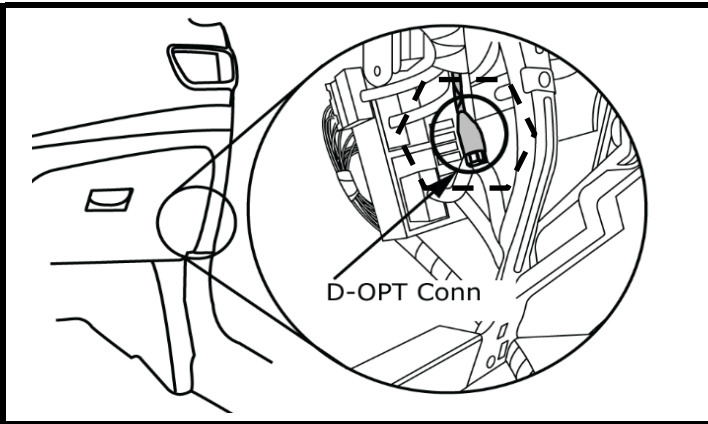

- 3.9) Locate RH D-Opt connector
- Locate Dealer- Option connector taped to main harness bundle.

D-Opt Connector



SECTION 3 - TRIM REMOVAL (CENTER CONSOLE FINISHER)

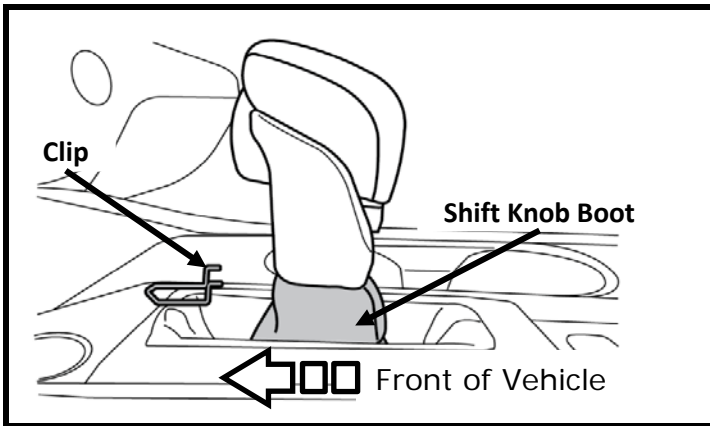

3.10) Remove gear selector knob.

- a) With shift lever in neutral position, use nylon pry tool to release finisher ring at bottom of shift knob and push boot down.
- b) Remove retaining clip holding shifter knob to selector lever, as shown.
- c) Lift shift knob upward to remove and reinstall clip with bend upward. Set shift knob aside.

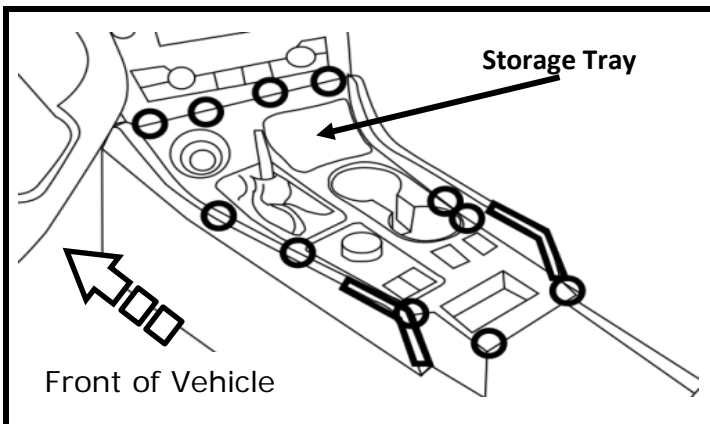

3.11) Console Finisher Removal

- a) Locate panel clips, as shown



CAUTION

Apply Protective Tape to console along top edges and rear corners to protect leather.

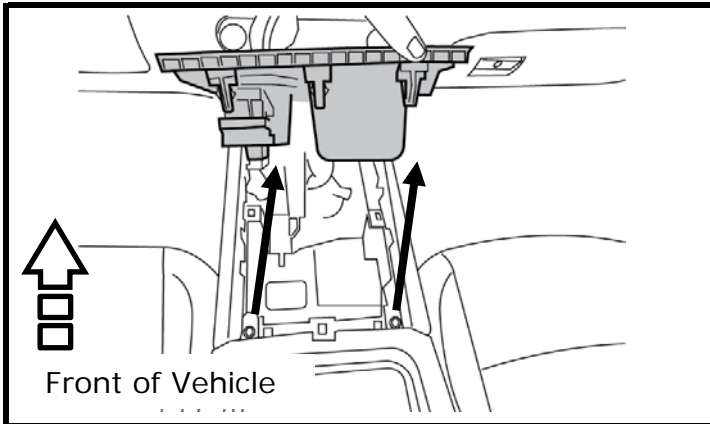

3.12) Console Finisher Removal

- a) Using Nylon Trim stick, begin at rear of console finisher and remove clips (if any) on console finisher.
- b) Tilt finisher towards front and pull back carefully to remove as shown.

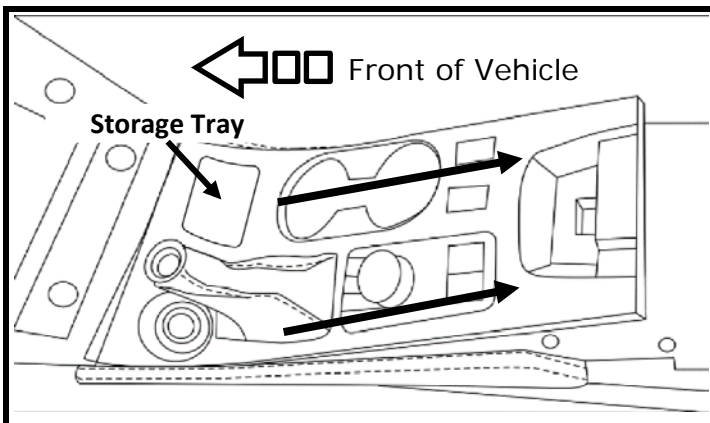

3.13) Console Finisher Removal

- a) Using Nylon Trim stick, begin at rear of console finisher and remove clips (if any) on console finisher.
- b) Tilt finisher towards front and then pull back carefully to remove as shown.

SECTION 3 - TRIM REMOVAL (CENTER CONSOLE FINISHER)

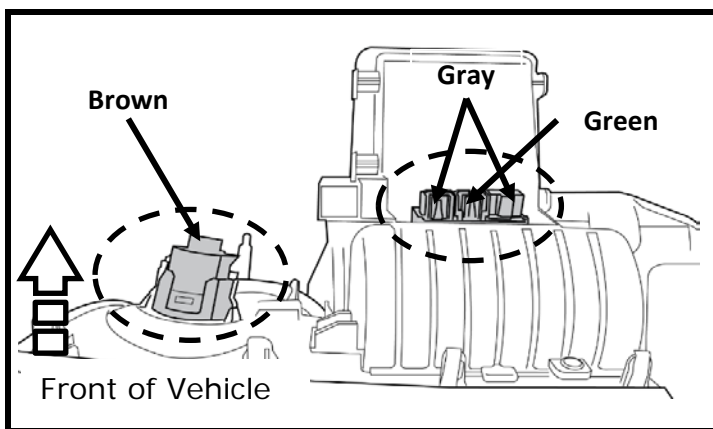

- 3.14) Disconnect all harnesses from console finisher.
 - a) Disconnect 2 Gray and 1 Green USB connector from socket and set aside, as shown.
 - b) Disconnect brown connector from socket and set aside, as shown.
 - c) Disconnect any other connectors (A/T shifter, I-key, P-Brake, etc.) under console. Do not try to disconnect clip holding harness.



CAUTION

Set console finisher aside carefully with harness clip connected to center console.

SECTION 4 - INSTALLATION PROCEDURE (CENTER CONSOLE BIN SWITCH)

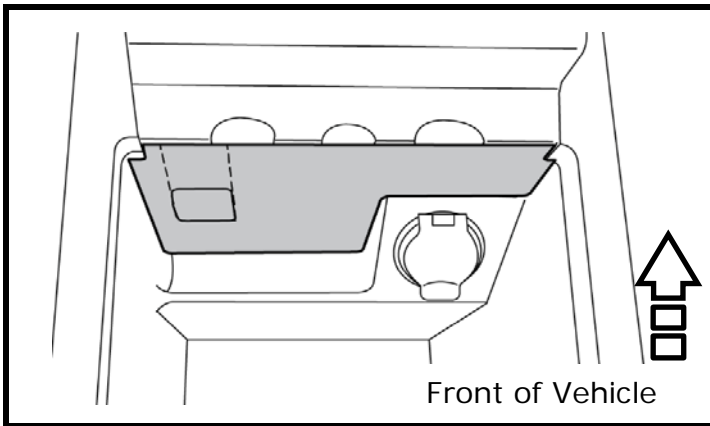

- 4.1) Install Switch template.
 - a) Using scissors, cut out switch paper template from Appendix C.
 - b) Tape template at location shown
 - c) Mark hole using (Awl) Center Hole Punch tool.

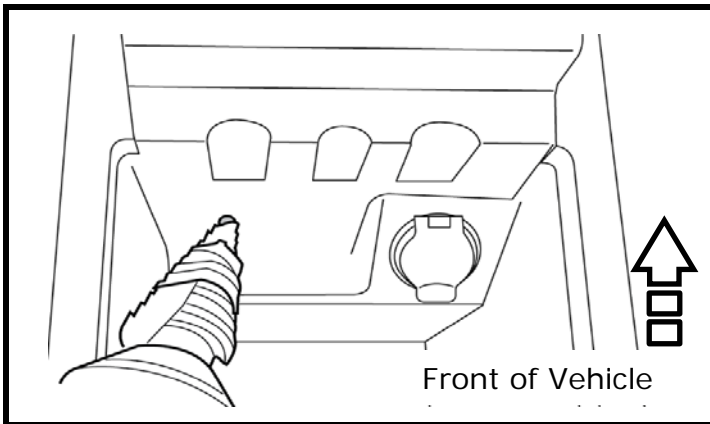

- 4.2) Install switch.
 - a) Using template, Drill 1/8" pilot hole using 90 Degree Small Drill.
 - b) Drill 3/8" hole for switch using 90 Degree Small Drill.



CAUTION

- When drilling, be extremely careful of modules and harnesses on back of panel
- Always use drill bit stop to control drilling depth to 1/4"

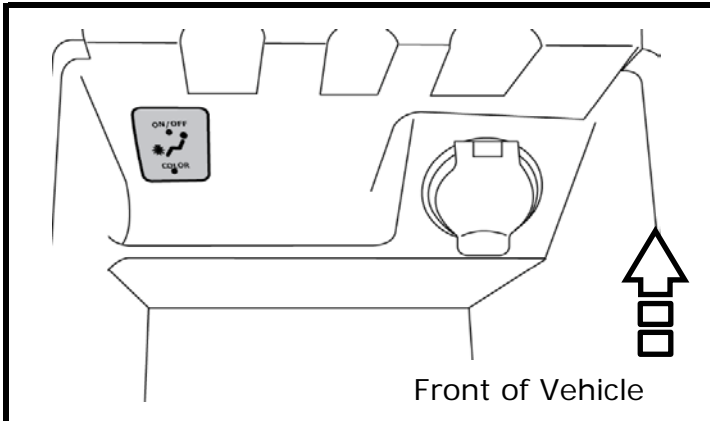

- 4.3) Install switch.
 - a) Remove burrs from holes and clear debris.
 - b) Clean with Alcohol wipe before installing switch.
 - c) Use mouting template as guide to install switch.
 - d) Insert harness connector in hole.
 - e) Align top of switch (D) parallel to recess line.
 - f) Contact switch adhesive to console.
 - g) Press firmly and hold. Apply 15 lbs. pressure for 20 seconds.

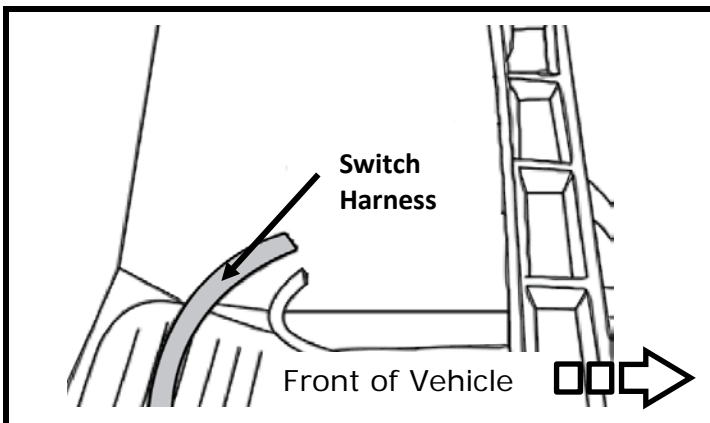

- 4.4) Routing Switch Harness.
 - a) Route harness under center console as shown and place piece foam tape (J) underneath.
 - b) Ensure that tape and harness are firmly secure to center console.



CAUTION

- Secure harness as needed every 200mm with Foam tape.

SECTION 5 - INSTALLATION PROCEDURE (FRONT FOOTWELL LIGHTS)

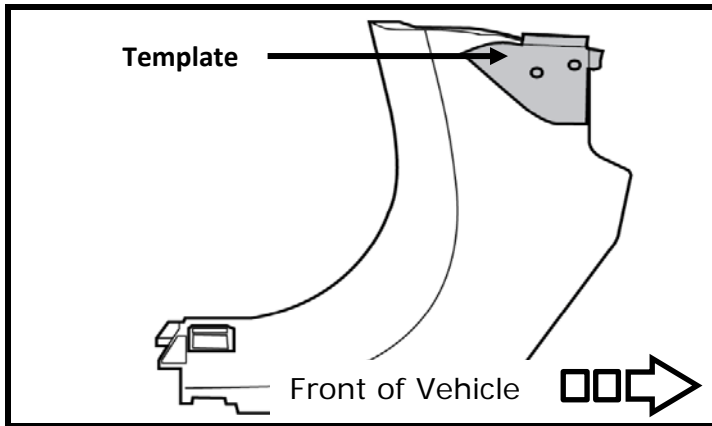

- 5.1) LH side light mounting on kick panel finisher.
 - a) Using scissors, cut out LH footwell paper template from Appendix C.
 - b) Measure 1" scale box to confirm size.
 - c) If scale box is too large, reduce image %.
 - d) Mark hole using (Awl) Center Hole Punch tool.

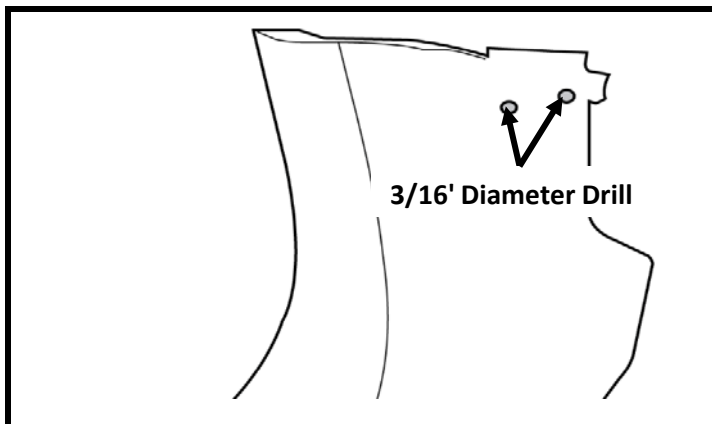

- 5.2) LH side light mounting on kick panel finisher.
 - a) Using template, Drill 1/8" pilot hole using 90 Degree Small Drill
 - b) Drill 3/16" hole for switch using 90 Degree Small Drill.



CAUTION

- When drilling, be extremely careful of modules and harnesses on back of panel
- Always use drill bit stop to control drilling depth to 1/4"

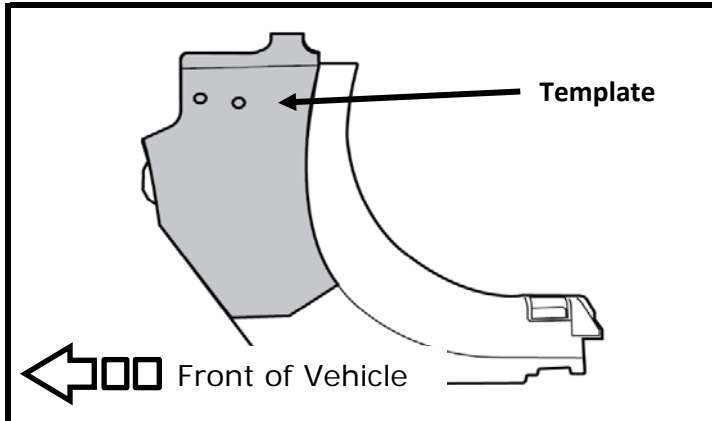

- 5.3) RH side light mounting on kick panel finisher.
 - a) Using scissors, cut out RH footwell paper template from Appendix C.
 - b) Measure 1" scale box to confirm size.
 - c) If scale box is too large, reduce image %.
 - d) Mark hole using (Awl) Center Hole Punch tool.

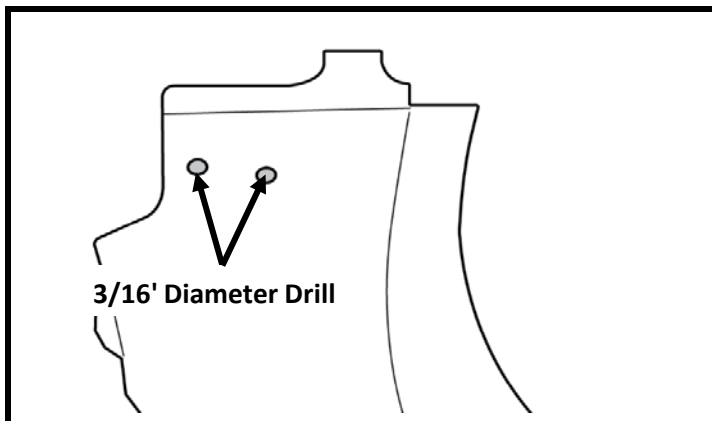

- 5.4) RH side light mounting on kick panel finisher.
 - a) Using template, Drill 1/8" pilot hole using 90 Degree Small Drill
 - b) Drill 3/16" hole for switch using a 90 Degree Small Drill.



CAUTION

- When drilling, be extremely careful of modules and harnesses on back of panel
- Always use drill bit stop to control drilling depth to 1/4"

SECTION 5 - INSTALLATION PROCEDURE (FRONT FOOTWELL LIGHTS)

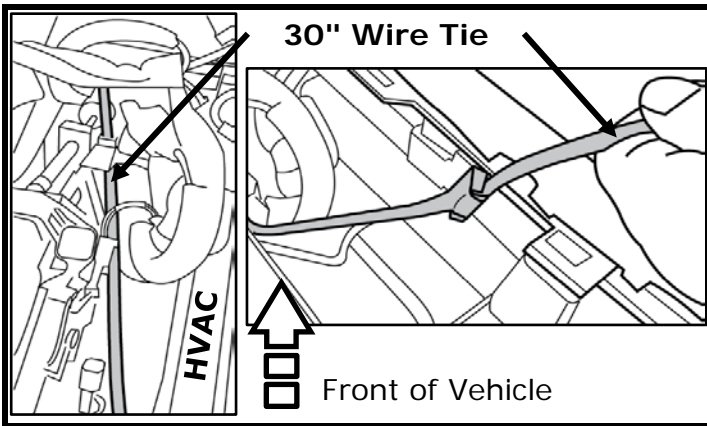

- 5.5) RH side footwell light & Power harness Routing
 - a) Tape footwell light and harness assembly (B) and vehicle interface harness (E) to wire tie, 30 inch (G) as shown.
 - b) Fish wire tie, 30 inch (G) from front of vehicle towards inside of center console.
 - c) Disconnect wire tie, 30 inch (G).

⚠ CAUTION

- **Ensure that "Y" junction is at center of console before moving to next steps.**

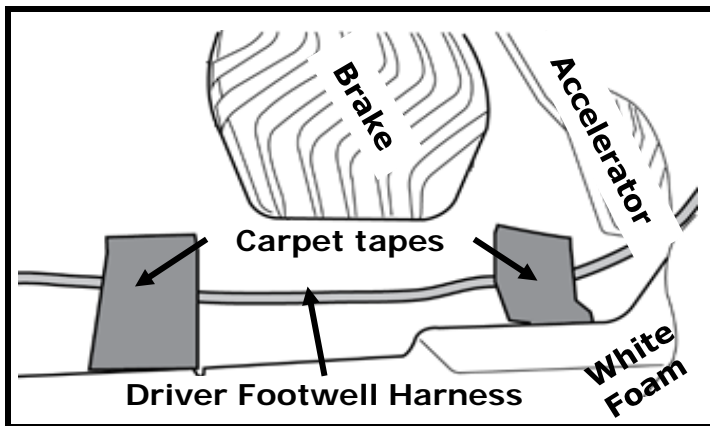

- 5.6) LH side footwell light & Power harness Routing
 - a) Pull carpet back & tape harness under carpet using 3M Beta Tape 5073 (K) to hold harness in place under carpet while routing harness to center console, as shown
 - b) Route harness to front of center console

⚠ CAUTION

- **Secure harness as needed every 200mm with Foam tape.**

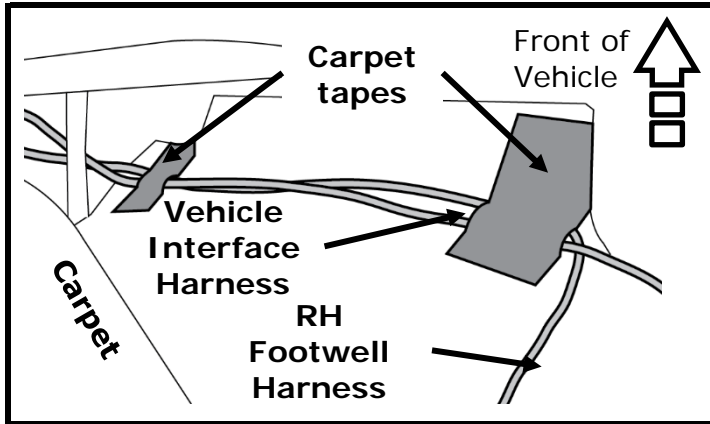

- 5.7) RH side footwell light & Power harness Routing
 - a) Pull carpet back & tape harness under carpet using 3M Beta Tape 5073 (K) to hold harness in place under carpet while routing harness to center console, as shown
 - b) Route harness to front of center console
 - c) Foam tape (J) Vehicle Interface Harness, as shown

⚠ CAUTION

- **Do Not Disturb Drain Tube**
- **Do Not Apply Wire Tie to Tube**
- **Ensure Harnesses Route Behind Tube**

SECTION 5 - INSTALLATION PROCEDURE (FRONT FOOTWELL LIGHTS)

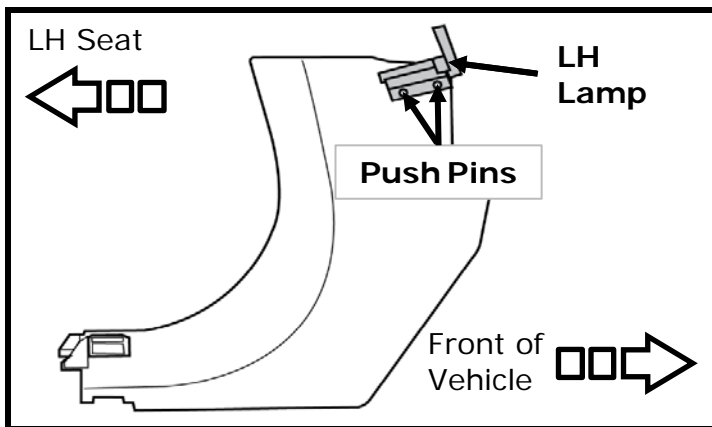

- 5.8) LH side footwell light mounting on kick panel finisher.
- Remove burrs from holes and clear debris.
 - Carefully attach LH side light using two push pin clips (M) pushed from front of panel to rear.
 - Ensure that driver kick panel finisher looks as shown, after installing footwell light.

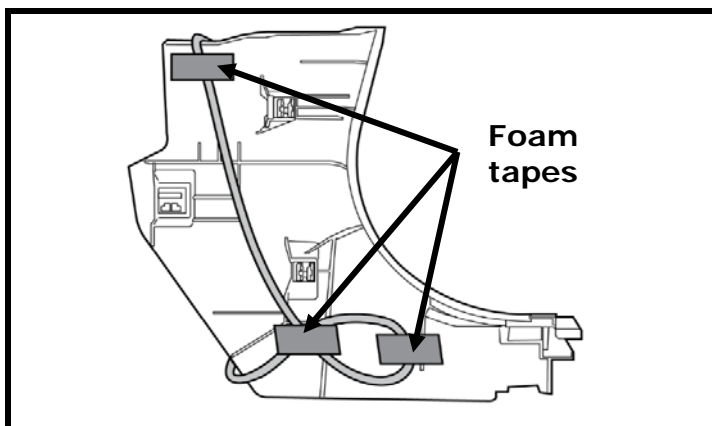

- 5.9) LH side footwell light harness routing
- Route LH side light harness behind finisher panel, make service loop and tape using Foam Tapes (J) on rear side of finisher panel, as shown.

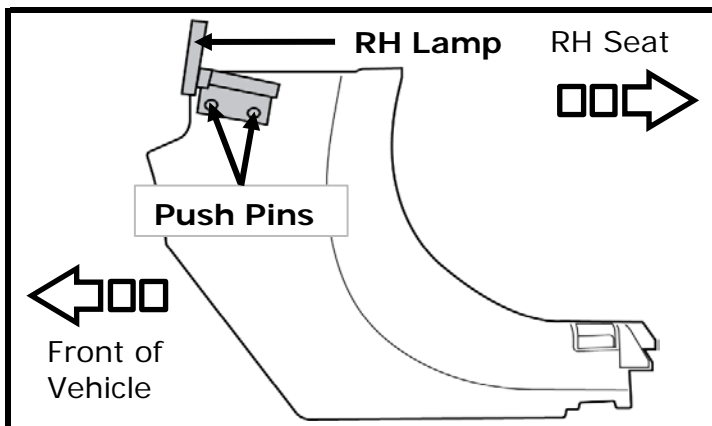

- 5.10) RH side footwell light mounting on kick panel finisher.
- Remove burrs from holes and clear debris.
 - Carefully attach RH side light using two push pin clips (M) pushed from front of panel to rear.
 - Ensure that RH kick panel finisher looks as shown, after installing footwell light.

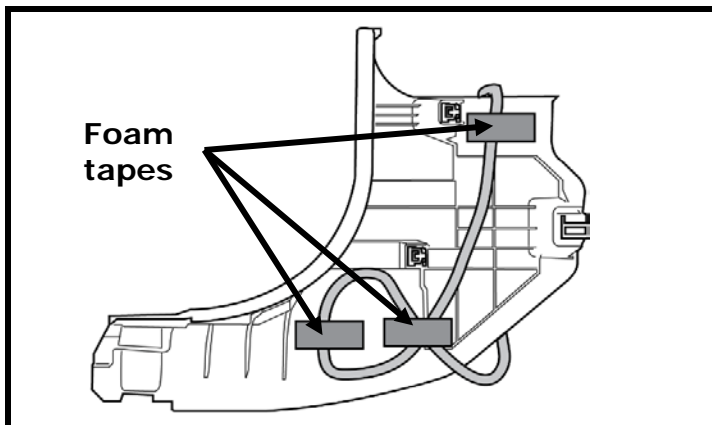

- 5.11) RH side footwell light harness routing
- Route RH side light harness behind finisher panel, make service loop and tape using Foam Tapes (J) on rear side of finisher panel, as shown.

SECTION 6 - INSTALLATION PROCEDURE (CUP HOLDER LIGHTS)

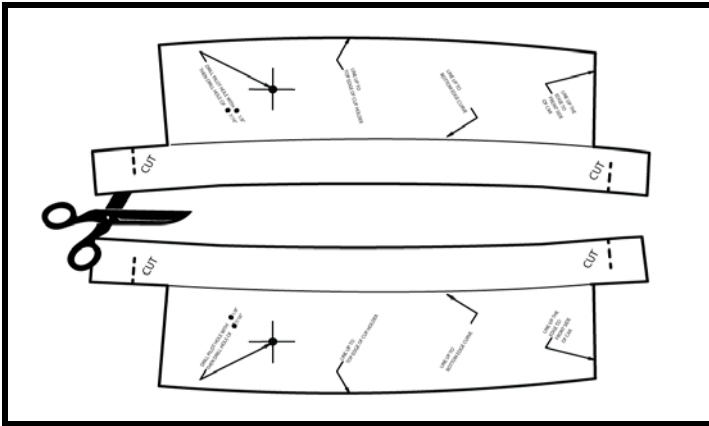

- 6.1) Install Cup holder light templates
 - a) Using scissors, cut out both paper template from Appendix C.
 - b) Measure 1" scale box to confirm size.
 - c) If scale box is too large, reduce image %.
 - d) Mark hole using (Awl) Center Hole Punch tool.

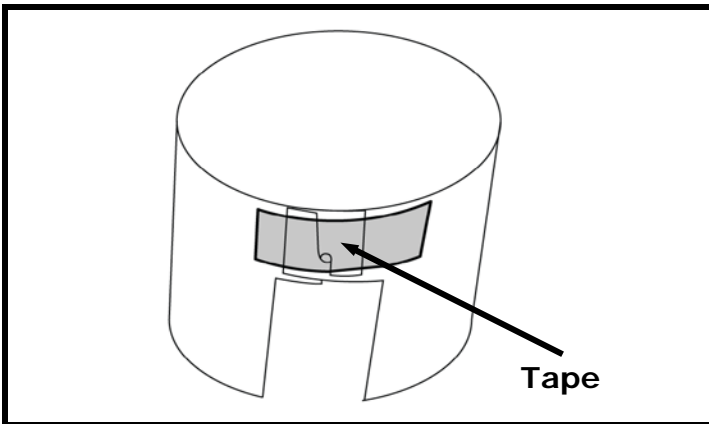

- 6.2) Install Cup holder light templates
 - a) Engage slits to interlock template for Cup holder. Tape flat to make collar, as shown.
 - b) Align templates to corresponding front and rear cup holders.

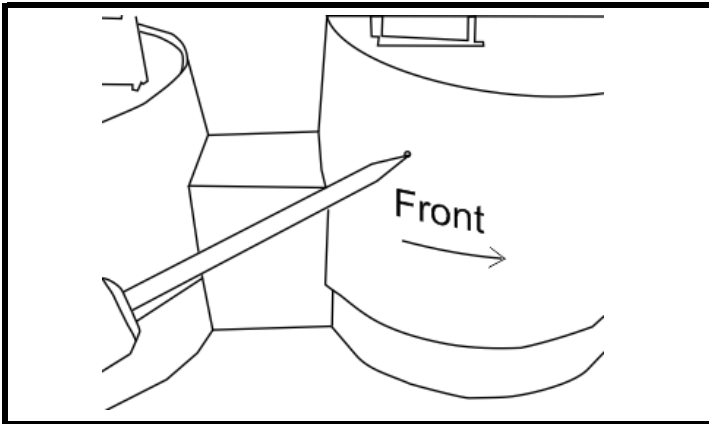

- 6.3) Install Cup holder light templates
 - a) Mark holes on both cup holders using (Awl) Center Hole Punch tool.

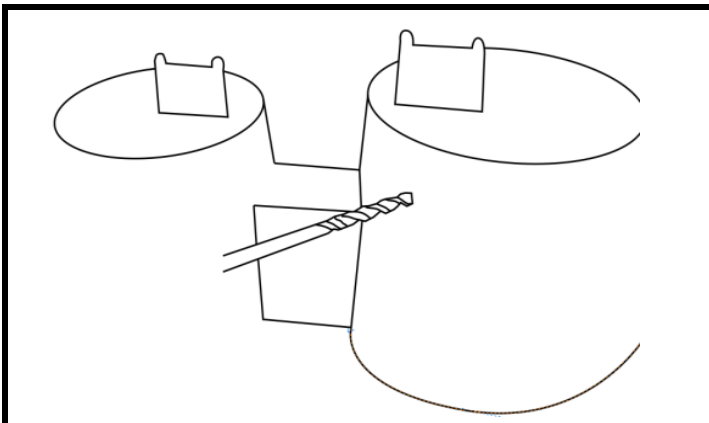

- 6.4) Install cup holder lights.
 - a) Using template, Drill 1/8" pilot hole using Small Drill for front and rear cup holders.
 - b) Drill 7/16" hole for switch using a Small Drill for front and rear cup holders.



CAUTION

- When drilling, be extremely careful of modules and harnesses on back of panel
- Always use drill bit stop to control drilling depth to 1/4"

SECTION 6 - INSTALLATION PROCEDURE (CUP HOLDER LIGHTS)

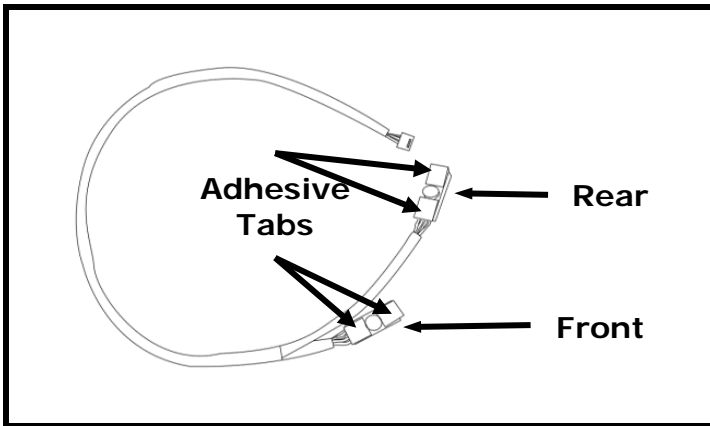

- 6.5) Install cup holder lights.
- Remove burrs from holes and clear debris.
 - Clean with Alcohol wipe (P) before installing cup holder lights.
 - Peel adhesive tabs from both lamp individually.

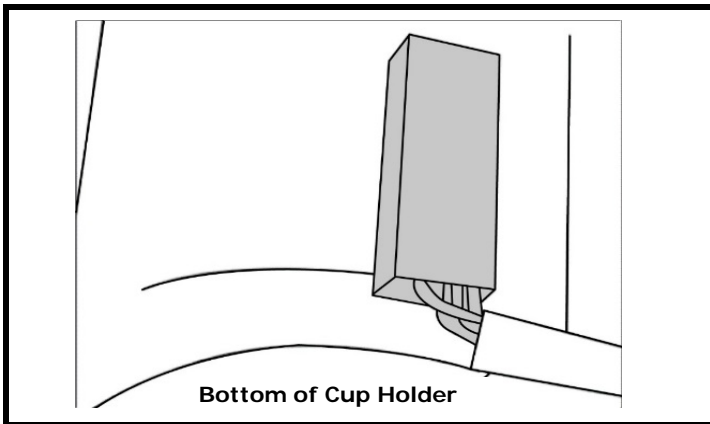

- 6.6) Cup holder lamp orientation
- Align lamp with cup holder lights and harness assembly (C), with bottom of cup holder.
 - Insert lamp lens in hole and contact adhesive pad to side of cup holder.
 - Inspect alignment and firmly press lamp against cup holder to bond.
 - Press front lamp firmly and hold. Apply 15 lbs. pressure for 20 seconds.

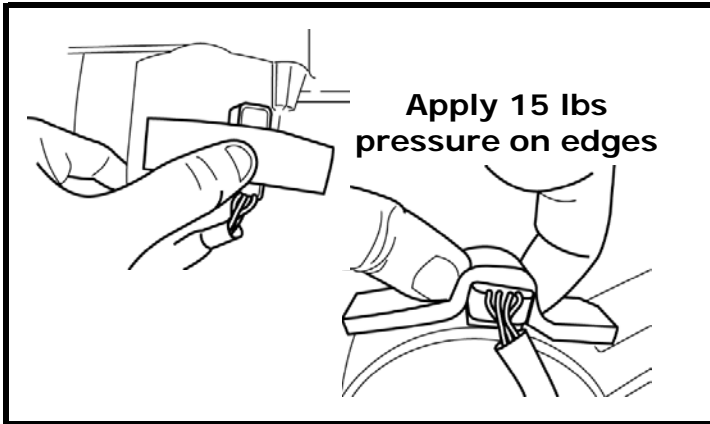

- 6.7) Installing Secondary Tape on Cup Holder Lamps
- Peel off adhesive and non-adhesive side papers from secondary foam tape (N).
 - Keeping proper alignment, place secondary foam tape (N) at center of rear side of cup holder lamps
 - Wrap tape along sides of lamp. Press firmly & apply even 15 lbs pressure for 20 seconds on either edges of lamp, as shown.

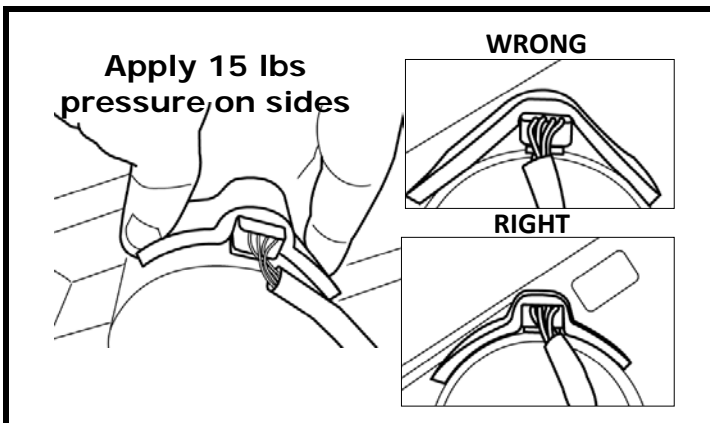

- 6.8) Installing Secondary Tape on Cup Holder Lamps
- Ensure that there are no air gaps on sides of lamp
 - Inspect installation to verify right installation, as shown.
 - Repeat steps 6.1) through 6.8) for other lamp.

SECTION 6 - INSTALLATION PROCEDURE (CUP HOLDER LIGHTS)

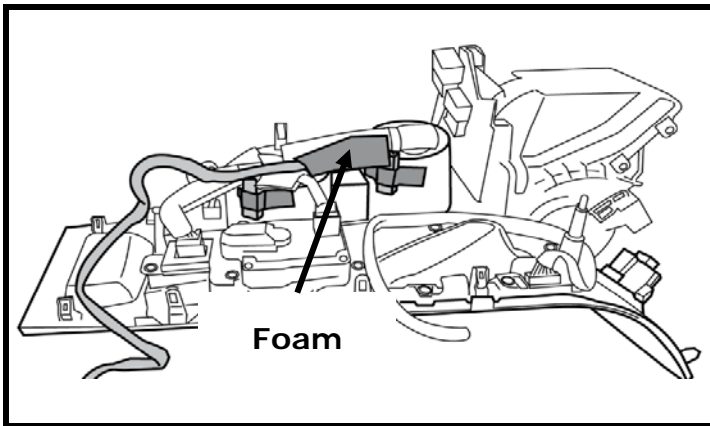

- 6.9) Route and secure cup holder light harness.
- Apply foam tape (J) to secure harness to side of rear cup holder, as shown.
 - Route harness along finisher toward front, as shown.

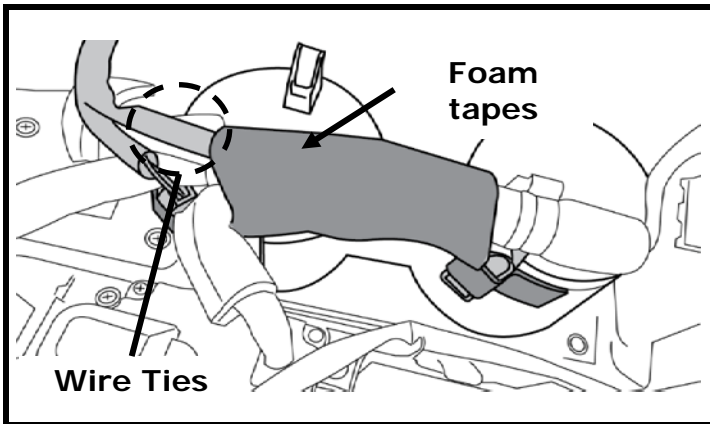

- 6.10) Route harness toward front of finisher.
- Using Wire Tie, 8 Inch (G), bundle both harnesses together, as shown
 - Using foam tape (J), bundle any extra harness in center console to avoid rattling & squeaking, as shown



CAUTION

- Insure all wire ties are tighten and clip off extra ends after this step



CAUTION

- **Accessory Service Connector is for use ONLY with Genuine Nissan (or Infiniti) or Nissan (or Infiniti) approved accessories. Use of this connector with non Genuine Nissan (or Infiniti) or Nissan (or Infiniti) approved accessories or failure to follow installation instructions for said connector being mentioned herein may result in damage to accessory and/or your vehicle.**
- **Nissan/Infiniti is not liable for loss or damage due to improper installation or installation of non Genuine or non approved accessories.**

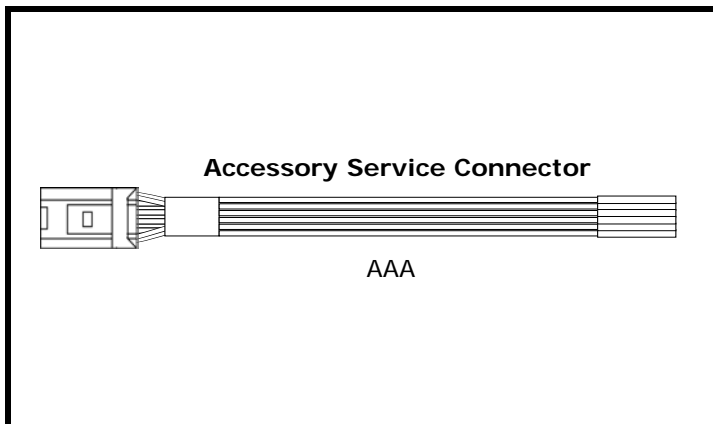

- 7.1) Connect ASC (AAA) to Accent Lighting Kit (ILK), Front RH
- a) For detailed directions, see Appendix A - Posi-Tap Procedure.
 - b) Additional circuit information is in Appendix B - Mechanization Drawing.

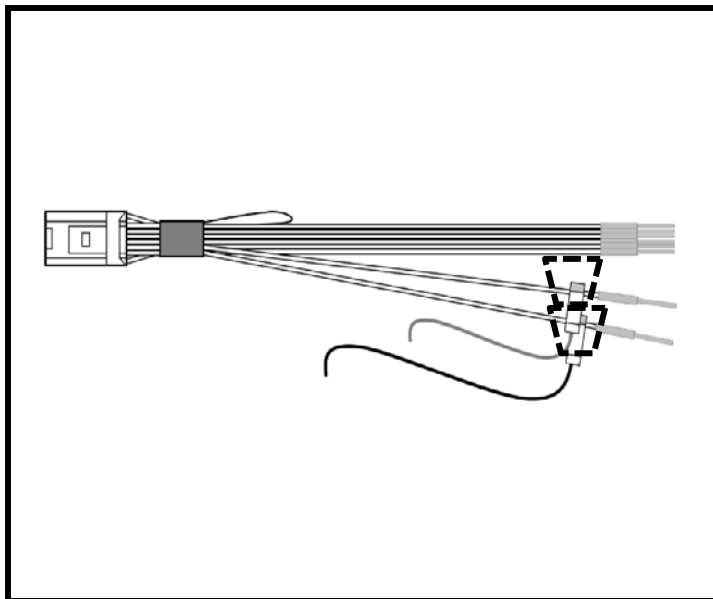

- 7.2) Connect ASC (AAA) to Accent Lighting Kit (ILK), Front RH
- a) Using a Posi-Tap (L), connect **BLACK** Vehicle Interface Harness to "**GND**" (**BLACK wire**) of ASC (AAA), as shown.
 - b) Using a Posi-Tap (L), connect **ORANGE** Vehicle Interface Harness to "**ACC**" (**ORANGE wire**) of ASC (AAA), as shown.
 - c) Using a Posi-Tap (L), connect **PINK** Vehicle Interface Harness to "**BATT_SAVER**" (**PINK wire**) of ASC (AAA), as shown.
 - d) Using a Posi-Tap (L), connect **YELLOW** Vehicle Interface Harness to "**ROOM_LAMP**" (**YELLOW wire**) of ASC (AAA), as shown.

Posi-tap™ (L)

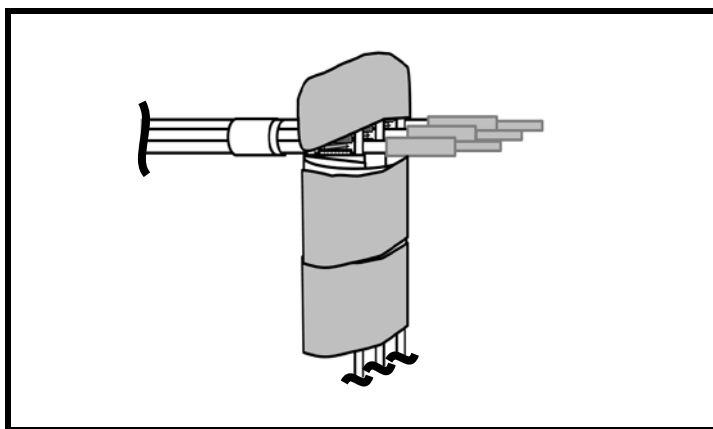

- 7.3) Connect ASC (AAA) to Accent Lighting Kit (ILK), Front RH
- a) Once ASC is prepared as described in Appendix A, ILK harness with ASC attached should be, as shown.

SECTION 7 - INSTALLATION PROCEDURE (ACCESSORY SERVICE CONNECTOR)

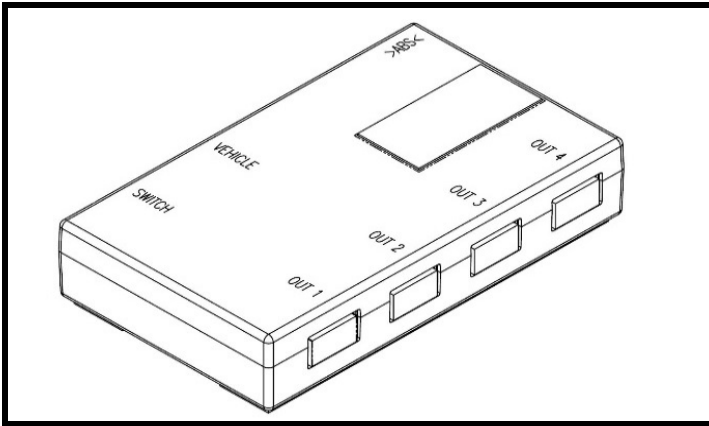

- 7.4) Control Module connection port identification.
- Connector footwell lamp into any 5 pin "OUT" ports.
 - Connector cup holder light harness into any 5 pin "OUT" ports.
 - Connector switch harness into 4 pin "SWITCH" port.
 - Connector power harness into 7 pin "VEHICLE" port.
 - Press firmly, listen for "Click" and give slight tug to check for all connections.

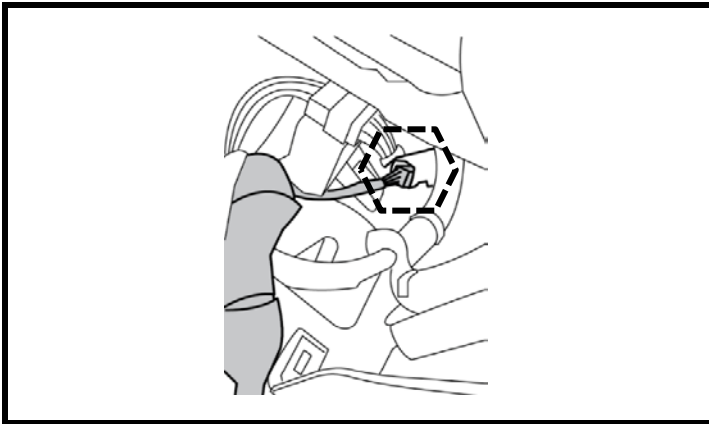

- 7.5) Connect ASC (AAA) to Accent Lighting Kit (ILK), Front RH
- Connector RH ASC into RH D-Opt connector.

D-Opt Connector

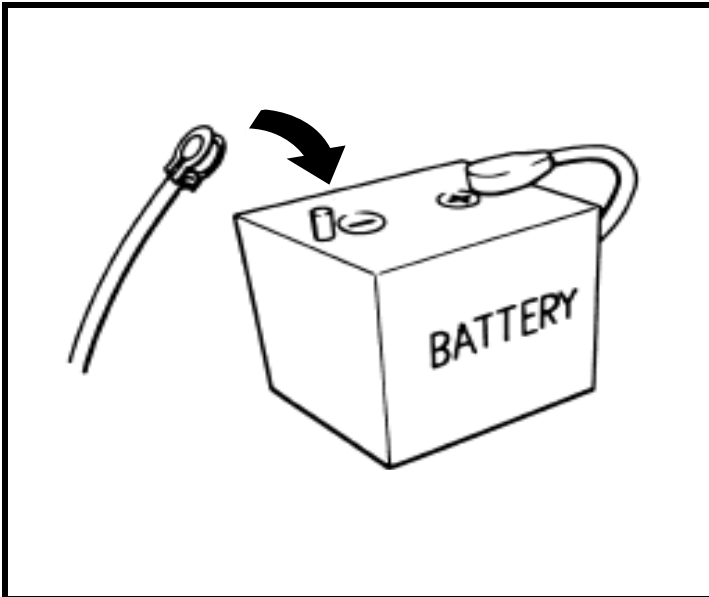

- 7.6) Electrical function check
- Re-connect negative battery cable
 - Confirm Interior Lighting Kit (ILK) turns ON in ACC & IGN modes respectively when ILK switch inside console box is ON.
 - If NG, check fusing, harness routing, connections, and Interior Accent Lights (ILK) to identify root cause.



CAUTION

• When diagnosing electrical system problems, first disconnect accessory connector (AAA) and note effect on system. Continue investigation with accessory connectors disconnected. Remember to reconnect accessories when investigation is complete.

SECTION 8 - INSTALLATION PROCEDURE (CONTROL MODULE MOUNTING)

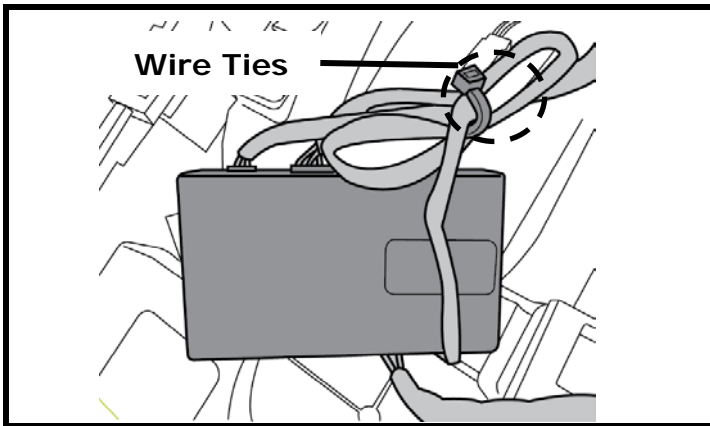

8.1) Control Module Placement

- a) Position Control Module (A) near center console.
- b) Bundle excess harness, wire tie, 8 inch (G) together, as shown



CAUTION

- Be sure to connect all harness connectors to control module BEFORE final mounting.

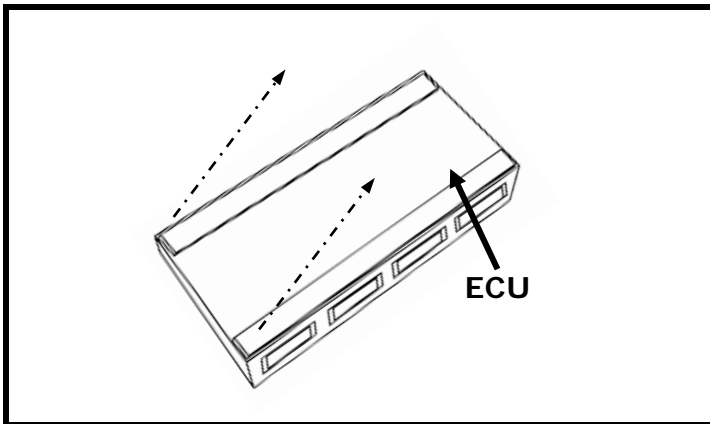

8.2) Control Module module mounting

- a) Peel off two backing papers from adhesive foam prior to placing Control Module (A), as shown.
- b) Position Control Module (A) before placing it, align vertically and make contact with the surface.
- c) Firmly press module to console floor and Hold in place for 30 seconds.



CAUTION

- Be sure to connect all harness connectors to the control module BEFORE final mounting.

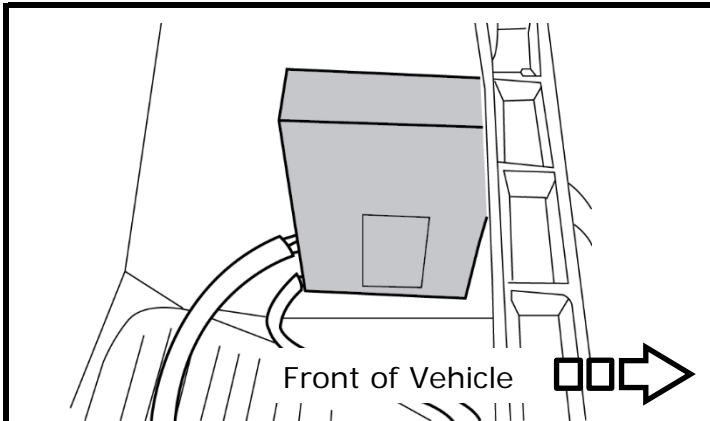

8.3) Control Module module mounting

- a) Ensure the placement of Control Module (A) is correct inside center console along LH, as shown.

SECTION 9 - INSTALLATION PROCEDURE (REINSTALL)

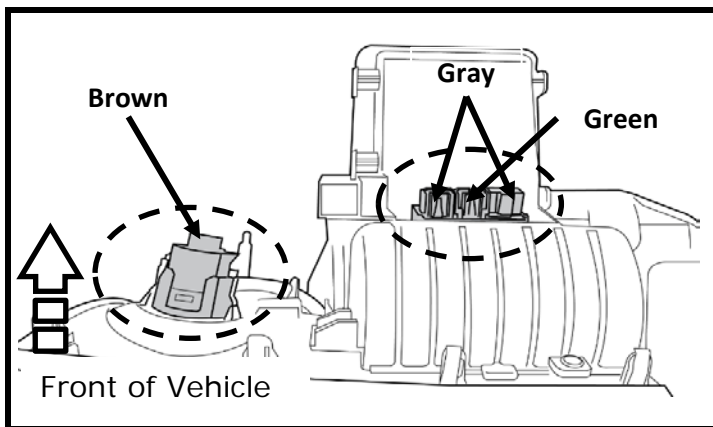

- 9.1) Reconnect all harnesses to center of console finisher.
 - a) Reconnect 2 Gray and 1 Green USB connector to socket, as shown.
 - b) Reconnect Brown connector to socket, as shown.
 - c) Reconnect any other connectors (A/T shifter, I-key, P-Brake, etc.) under console.

⚠ CAUTION

• **Conduct function check for ALL systems.**

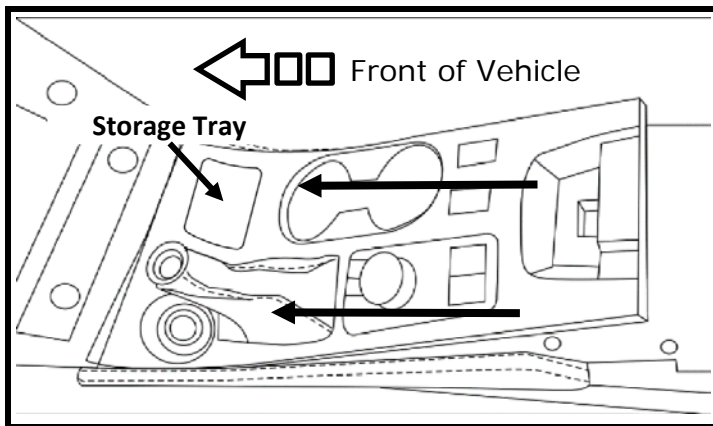

- 9.2) Reinstall center console finisher.
 - a) Check connections on finisher panel harness
 - b) Begin at front of console finisher and align clips into position on console finisher.
 - c) Tilt finisher towards front and then push in to carefully reinstall and engage clips, as shown.

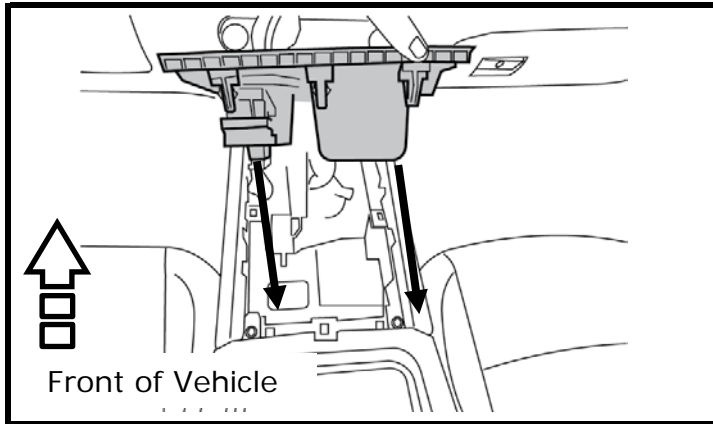

- 9.3) Reinstall center console finisher.
 - a) Position finisher panel over console.
 - b) Align clips and lower into position.
 - c) Carefully press down on finisher panel to engage remaining clips, as shown.

⚠ CAUTION

• **Conduct function check for ALL systems.**

• **Ensure E-Brake switch connectors are attached if present.**

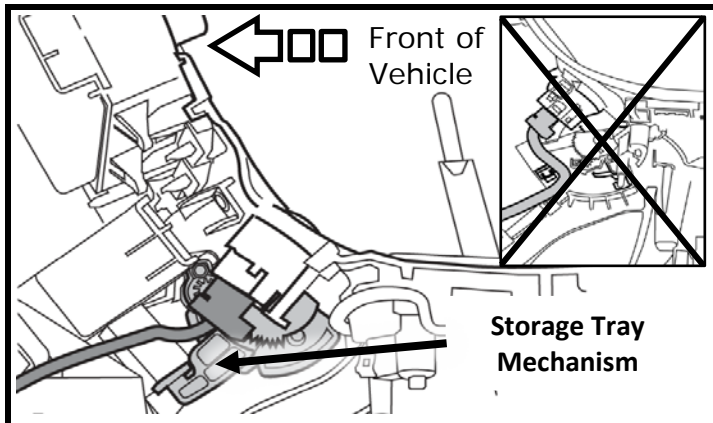

- 9.4) Reinstall center console finisher.
 - a) Ensure all harnesses are routed properly, as shown, verify harness is not getting pinched in storage tray mechanism.

⚠ CAUTION

• **Verify storage tray closes properly "twice" once center console finisher is reinstalled.**

SECTION 9 - INSTALLATION PROCEDURE (REINSTALL)

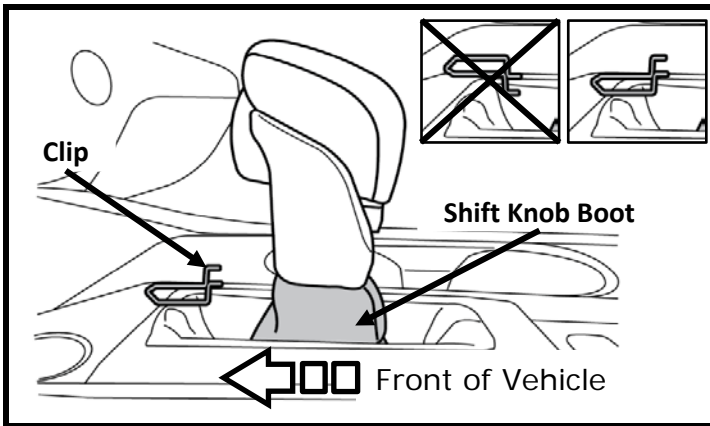

- 9.5) Reinstall gear selector knob.
 - a) Check clip placement ensure bend is upward for proper installation on knob, as shown.
 - b) Place knob on lever and press down.
 - c) Pull boot up and secure retainer ring to base of shift knob.

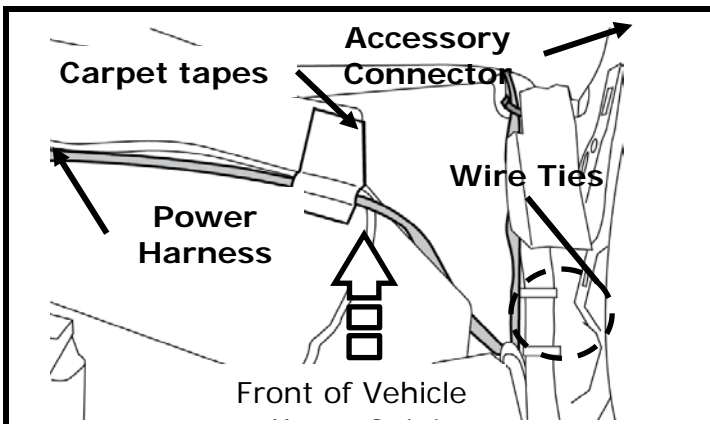

- 9.6) Route vehicle interface harness from Control Module to Accessory Connector.
 - a) Ensure vehicle interface harness (E) is secure with wire tie, 8 inch (G) as necessary to vehicle harness, as shown

⚠ CAUTION
• Insure all wire ties are tighten and clip off extra ends after this step

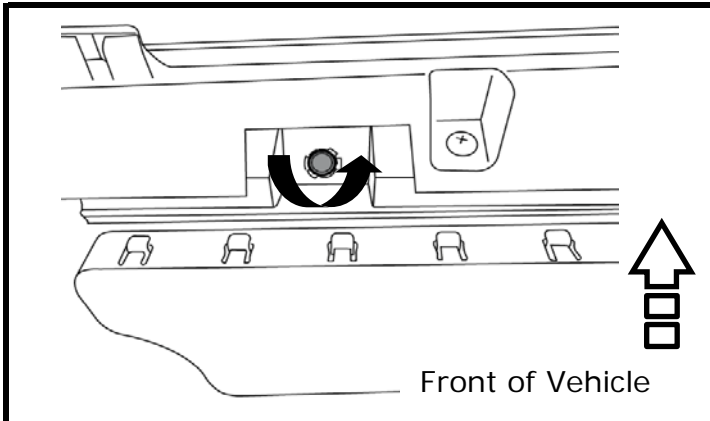

- 9.7) Factory footwell light Removal.
 - a) Ensure both LH and RH factory footwell lights are removed from vehicle, as shown



CAUTION

• **Take care not to scratch or damage any component during removal or re-installation process. Trim pieces found to have witness marks or broken clips should be replaced with new parts.**

10.1) Complete checklist:

- Tighten battery nut to 5 N-m
- Verify shift lever lock is engaged by checking with vehicle off, so shift lever can NOT be moved out of "P" (Park).
- Verify re-installed trim parts for proper fit (no gap, waviness, etc.), particularly door sill weather strip.
- Verify all windows and sunroof (if equipped), one touch operation and perform reset procedure if necessary. Refer to vehicle Service Manual for more details.
- Re-program radio presets and other vehicle settings to recorded settings if necessary.
- If this vehicle will be returned to dealer lot or showroom for extended period of time, be sure extended storage switch is placed in Transit position. (See step 2.2).
- Remove all tools, templates, and other debris from interior of vehicle.
- Verify vehicle headliner, seat, steering wheel, center console, carpet, etc. are not soiled.
- Verify interior and exterior are not damaged.
- Verify proper open/close function of Storage Tray.

APPENDIX A - POSI-TAP PROCEDURE

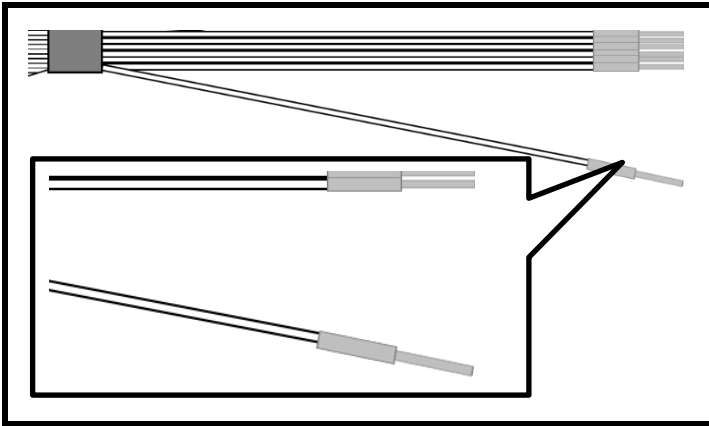

A.1) Installing Posi-Tap™ on Accessory Service Connector (AAA)

- a) Identify and confirm ASC wire to be tapped. Check color as well as connector location.
- b) Separate wire from rest of bundle.



CAUTION

- Do not overtighten Posi-Tap, it may damage wire

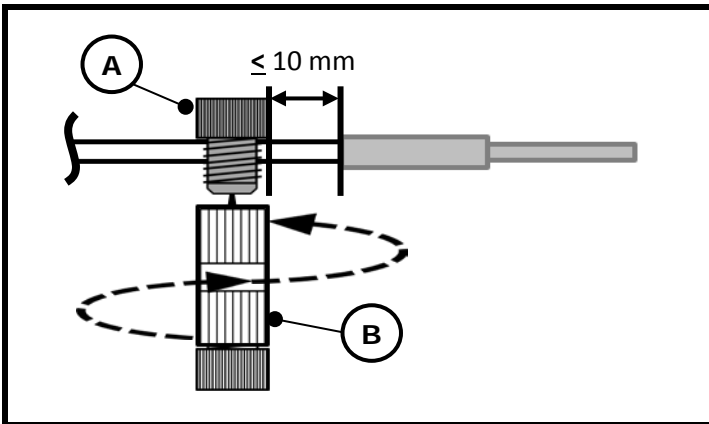

A.2) Installing Posi-Tap™ on ASC (AAA)

- a) Remove pierce cap (A) gray side from tap body (B).
- b) Slide cap around single wire to be tapped
- c) Position cap $< 10\text{ mm}$ away from heat shrink end of connector
- d) Turn tap (B) clockwise until finger "tight". Then secure to cap (A) with another $\frac{1}{4}$ turn.

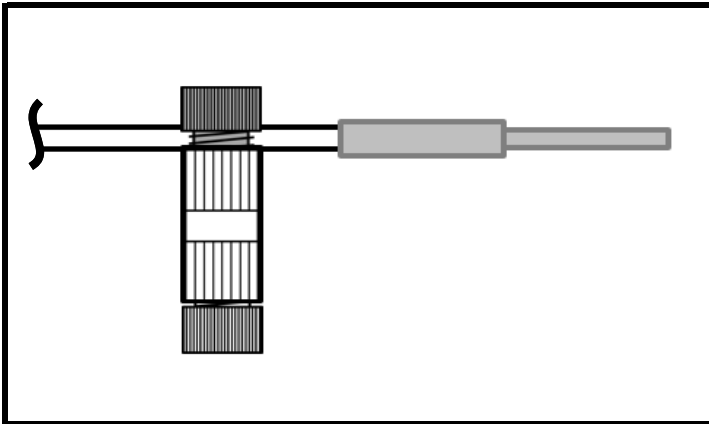

A.3) Installing Posi-Tap™ on ASC (AAA)

- a) Inspect Posi-Tap™ to ensure correct installation.
- b) Wire jacket should be crushed enough to maintain pressure.
- c) Confirm tap cap gap is straight and evenly spaced around perimeter.

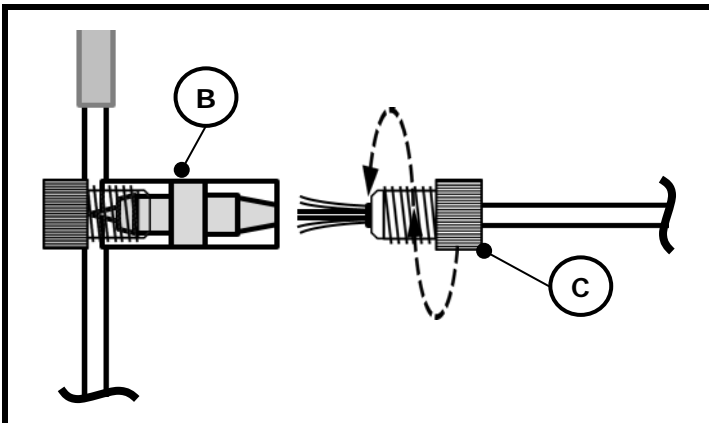

A.4) Installing Accessory wire into Posi-Tap™

- a) Remove tap bottom (C) red side from tap body (B).
- b) Remove the pre cut insulation from correct Accessory wire.
- c) Insert wire through tap bottom (C) opening.
- d) Fan out individual wire strands as shown.
- e) Insert wire into tap body until it bottoms out.
- f) Turn tap bottom (C) clockwise until finger "tight". Then secure to tap body (B) with another $\frac{1}{4}$ turn.

APPENDIX A - POSI-TAP PROCEDURE

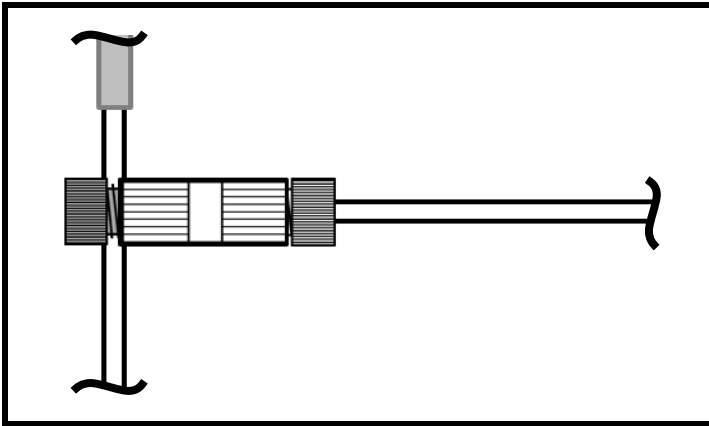

- A.5) Installing accessory wire into Posi-Tap™
- Confirm tap bottom gap is straight and evenly spaced around perimeter
 - Gently pull on wire to confirm secure connection.

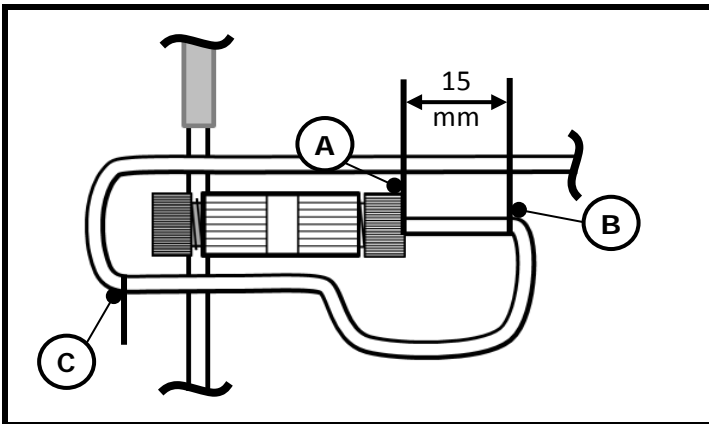

- A.6) Accessory wire strain relief
- Measure ≥ 15 mm from point (A).
 - Gently form loop at point (B) and bend back up towards Posi-Tap™ (bend radius ≥ 10 mm).
 - Gently form loop at point (C) and bend back over top of Posi-Tap™ and down opposite side (bend radius ≥ 10 mm).

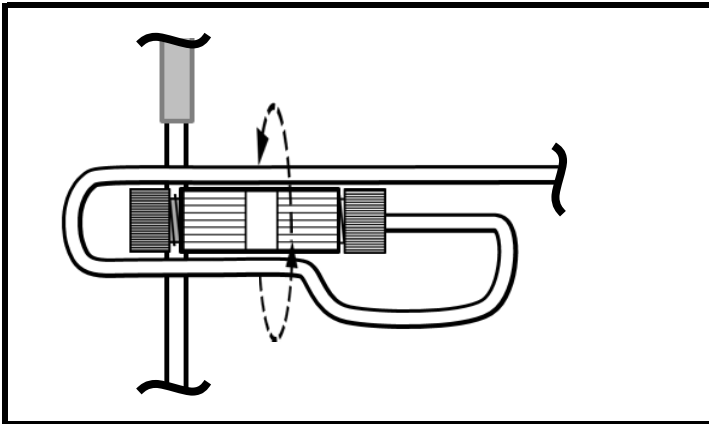

- A.7) Accessory wire strain relief
- Secure accessory wire strain relief to tap body with electrical tape (≥ 2 revolutions).
 - Once accessory wire strain relief is taped to tap body, it should look as shown.

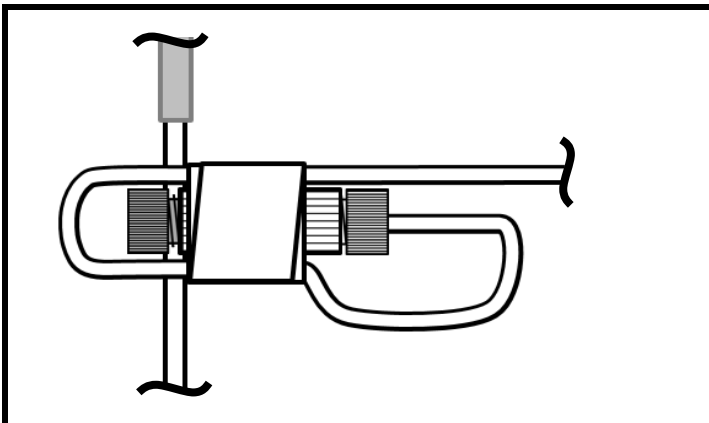

- A.8) Installing Posi-Tap™ on ASC (AAA)
- Repeat steps A.1 - A.8 for all other wires requiring Posi-Tap™.

APPENDIX A - POSI-TAP PROCEDURE

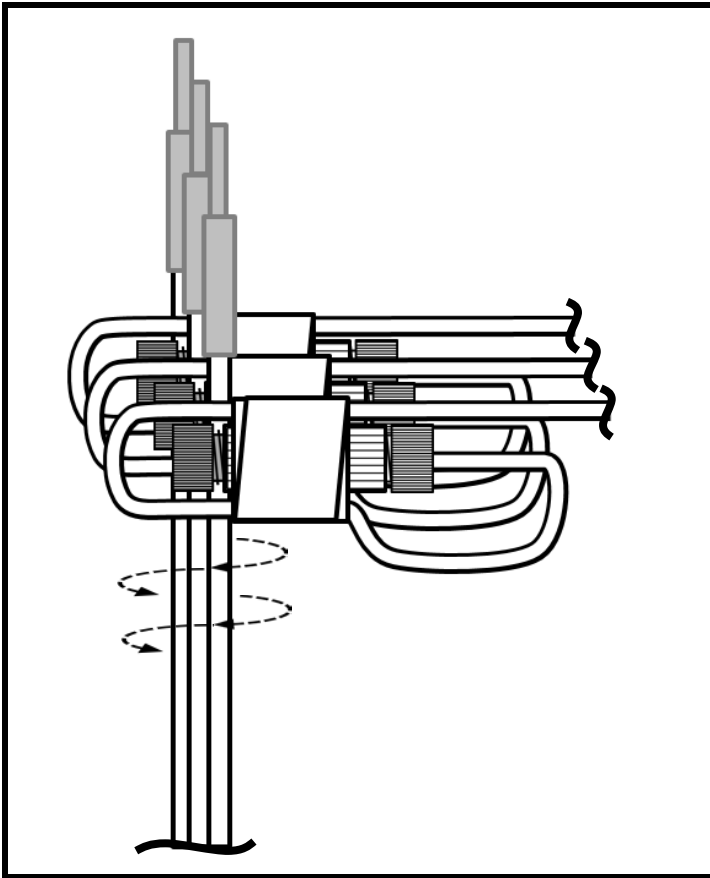

- A.9) Securing multiple Posi-Taps™ together
- Stack Posi-Taps™ in slightly staggered fashion as shown.
 - Secure tapped circuits together with electrical tape (≥ 2 revolutions).

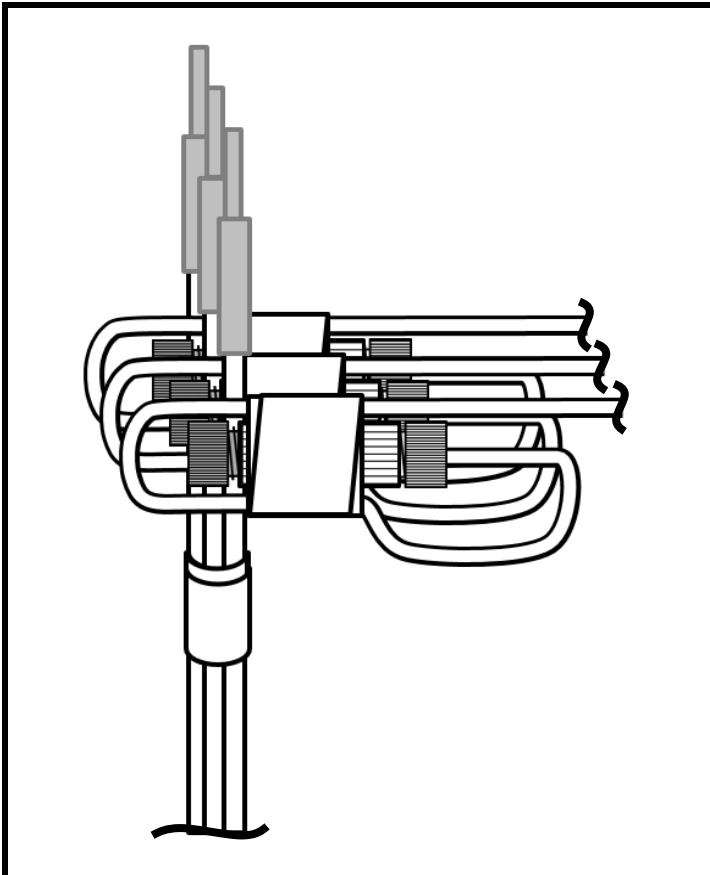

- A.10) Securing multiple Posi-Taps™ together
- Once tapped circuits are secured together with electrical tape they should look as shown.

APPENDIX A - POSI-TAP PROCEDURE

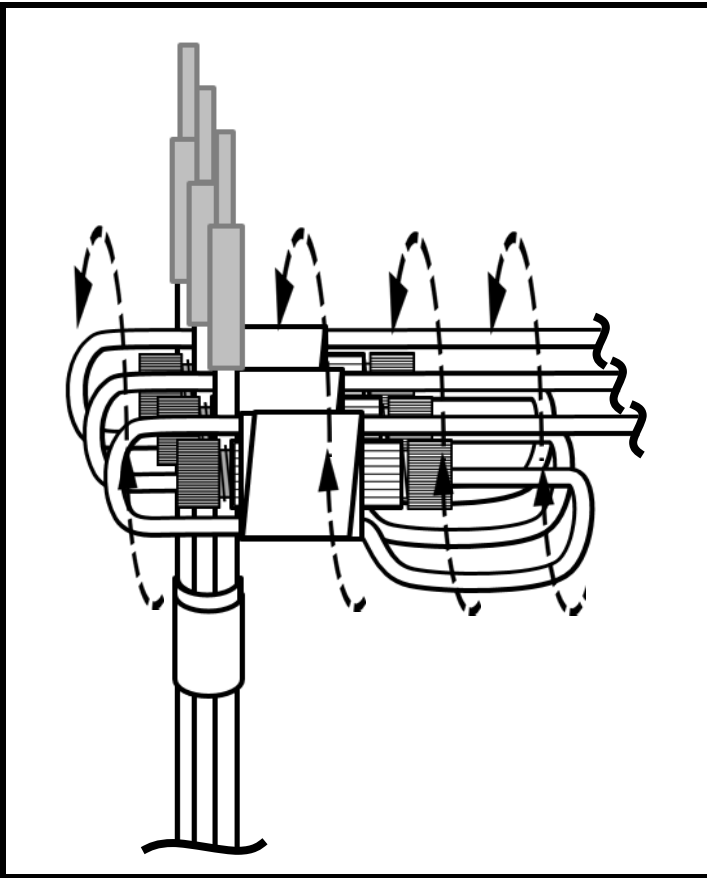

A.11) Securing multiple Posi-Taps™ together

- a) Secure Posi-Taps™ together with electrical tape (≥ 4 revolutions).

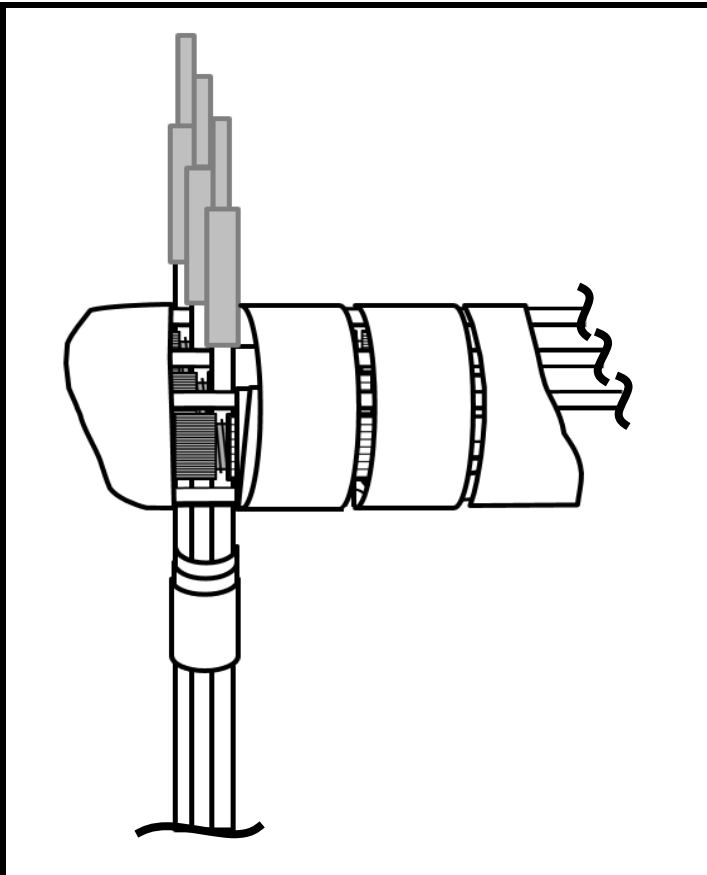

A.12) Securing multiple Posi-Taps™ together

- a) Once Posi-Taps™ are secured together with electrical tape they should look as shown.

APPENDIX A - POSI-TAP PROCEDURE

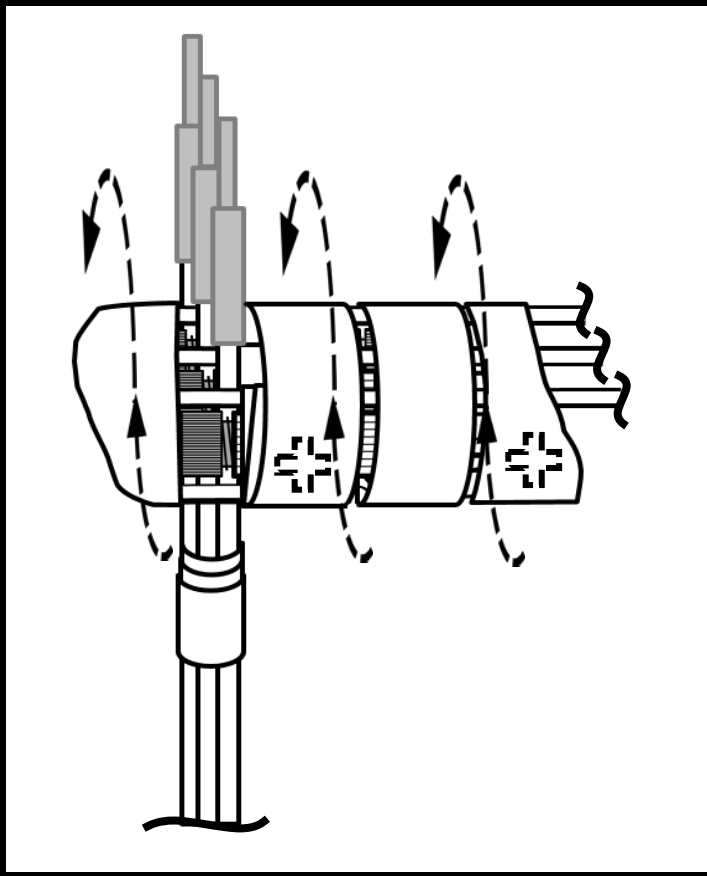

A.13) Securing multiple Posi-Taps™ together

- a) To prevent any possible noise or rattle issues, use two pieces of Foam Tape, Gray (H) to wrap pre-taped Posi-Taps™.

Foam Tape (J)

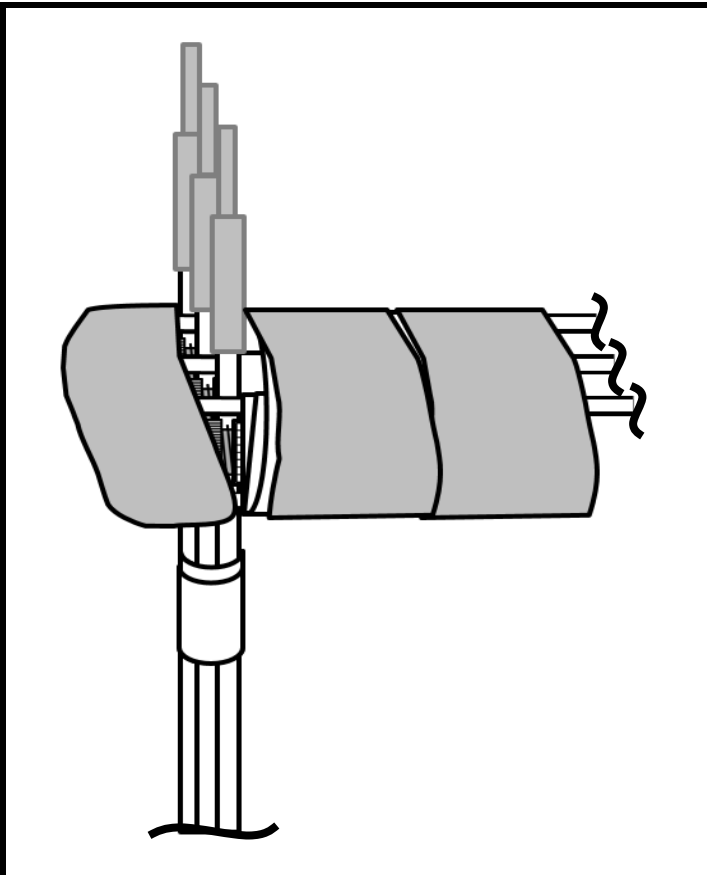

A.14) Securing multiple Posi-Taps™ together

- a) Once wrapped with Foam Tape, taped Posi-Tap™ bundle should look as shown.

APPENDIX B - MECHANIZATION DRAWING

B.1) Figure below applies to the Accent Lighting connected to the RH ASC

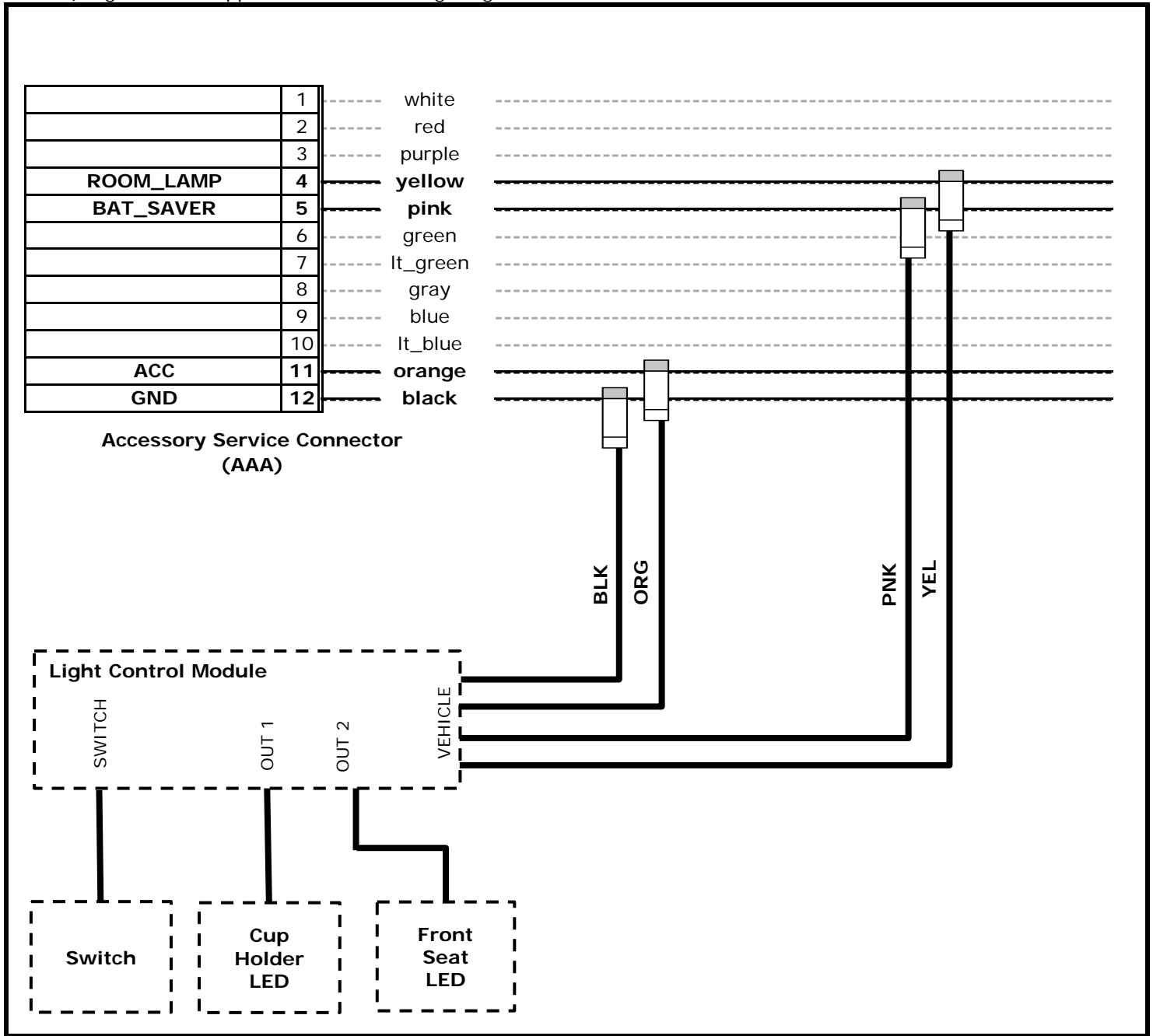

CONNECTOR PN#	T99F6 4RA0A	LEGEND
CONNECTOR NAME	ACCESSORY SERVICE CONNECTOR	<p>POSI-TAP</p> <p>GRAY - CIRCUIT TAP (PIERCE) SIDE</p> <p>RED - ACCESSORY (INSERT) SIDE</p>
CONNECTOR COLOR	WHITE	
		<p>Note: Pin location is referenced looking into harness side of connector with lock tab oriented as shown.</p>

Page Intentionally Left Blank

APPENDIX C - LOCATION TEMPLATE

CAUTION

Template **MUST** be printed to scale in both directions. Check printout by using scales below.
DO NOT run with scissors !

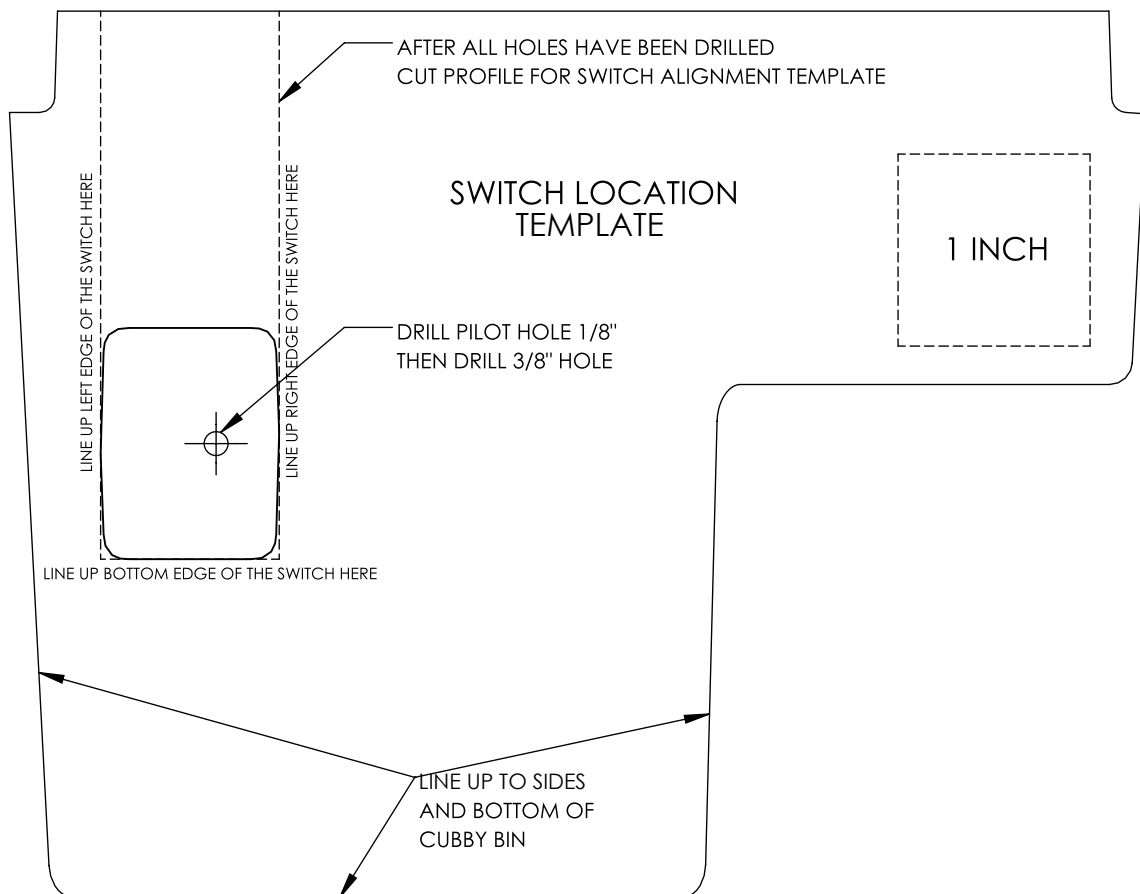

Page Intentionally Left Blank

APPENDIX C - LOCATION TEMPLATE

CAUTION

Template **MUST** be printed to scale in both directions. Check printout by using scales below.
DO NOT run with scissors !

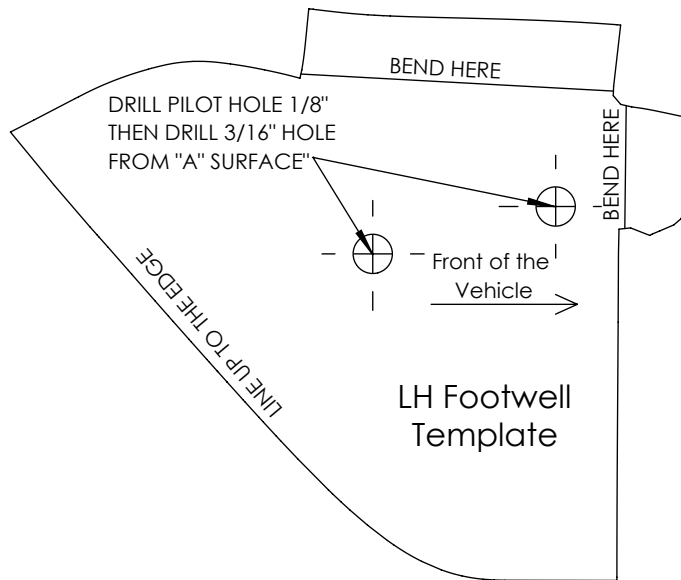
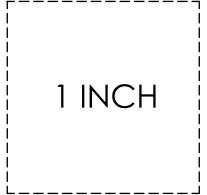

Page Intentionally Left Blank

APPENDIX C - LOCATION TEMPLATE

CAUTION

Template **MUST** be printed to scale in both directions. Check printout by using scales below.
DO NOT run with scissors !

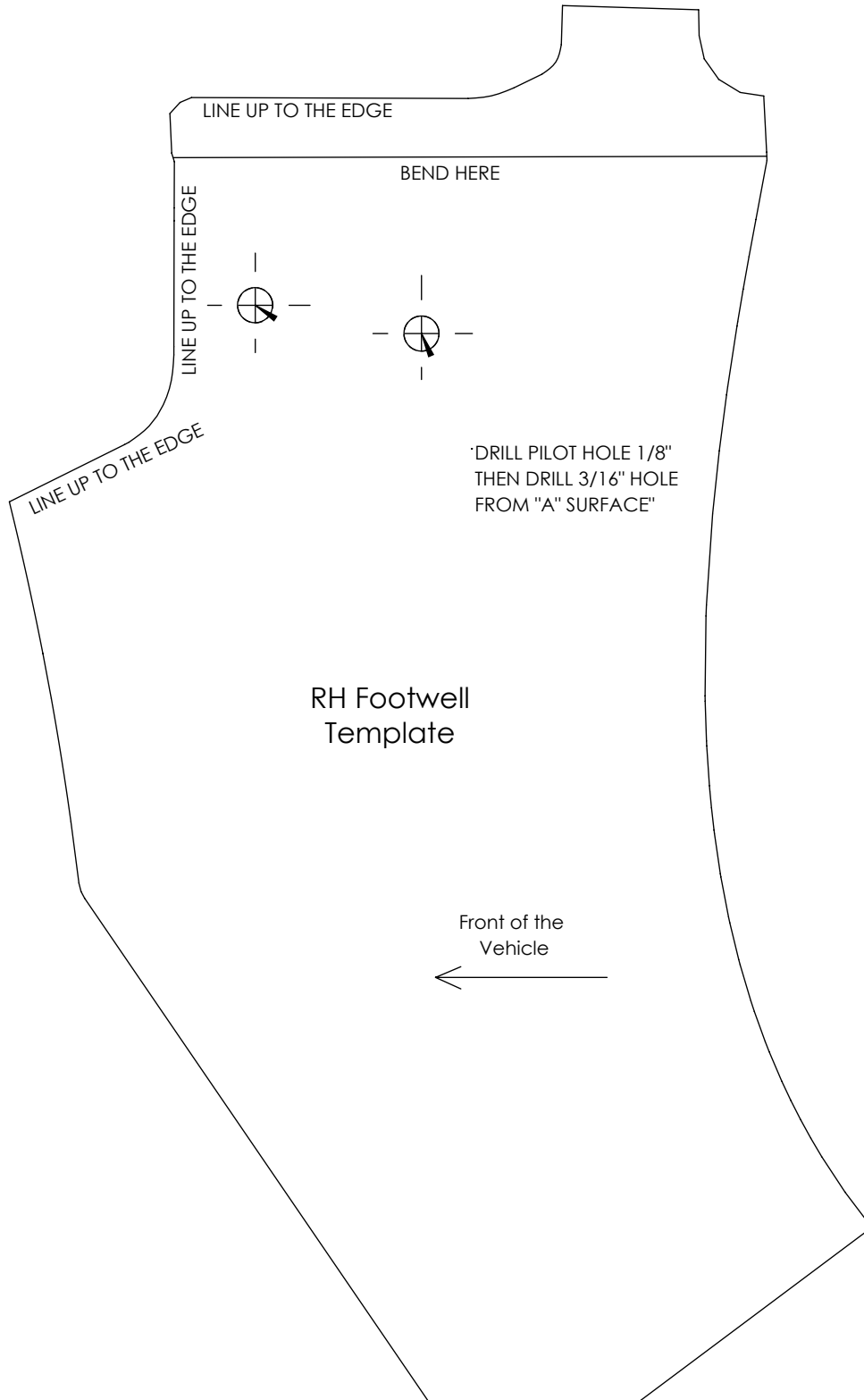
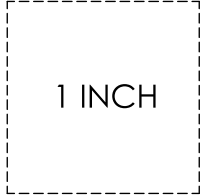

Page Intentionally Left Blank

APPENDIX C - LOCATION TEMPLATE

⚠ CAUTION

Template **MUST** be printed to scale in both directions. Check printout by using scales below. **DO NOT** run with scissors !

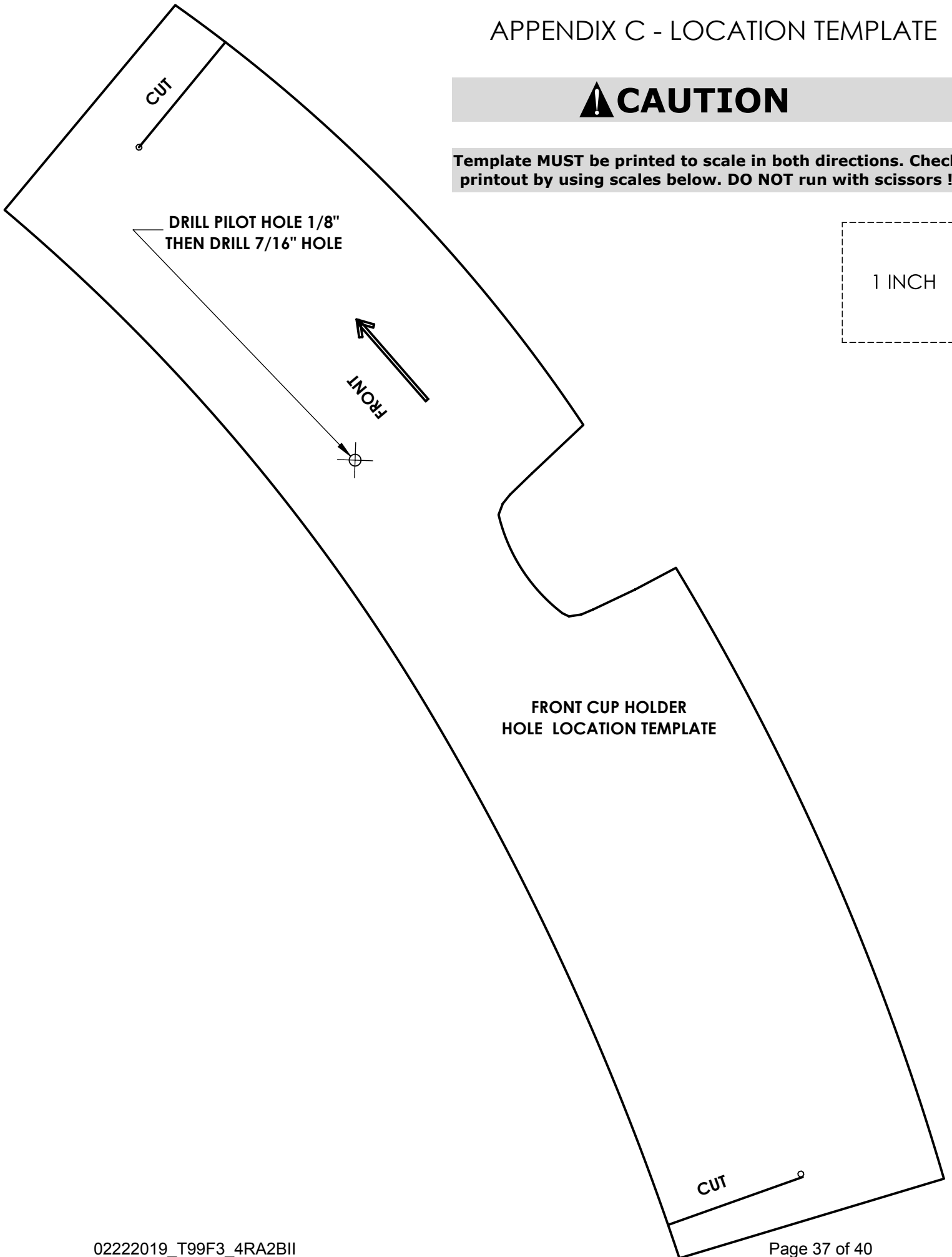
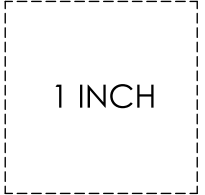

Page Intentionally Left Blank

APPENDIX C - LOCATION TEMPLATE

⚠ CAUTION

Template **MUST** be printed to scale in both directions. Check printout by using scales below. **DO NOT** run with scissors !

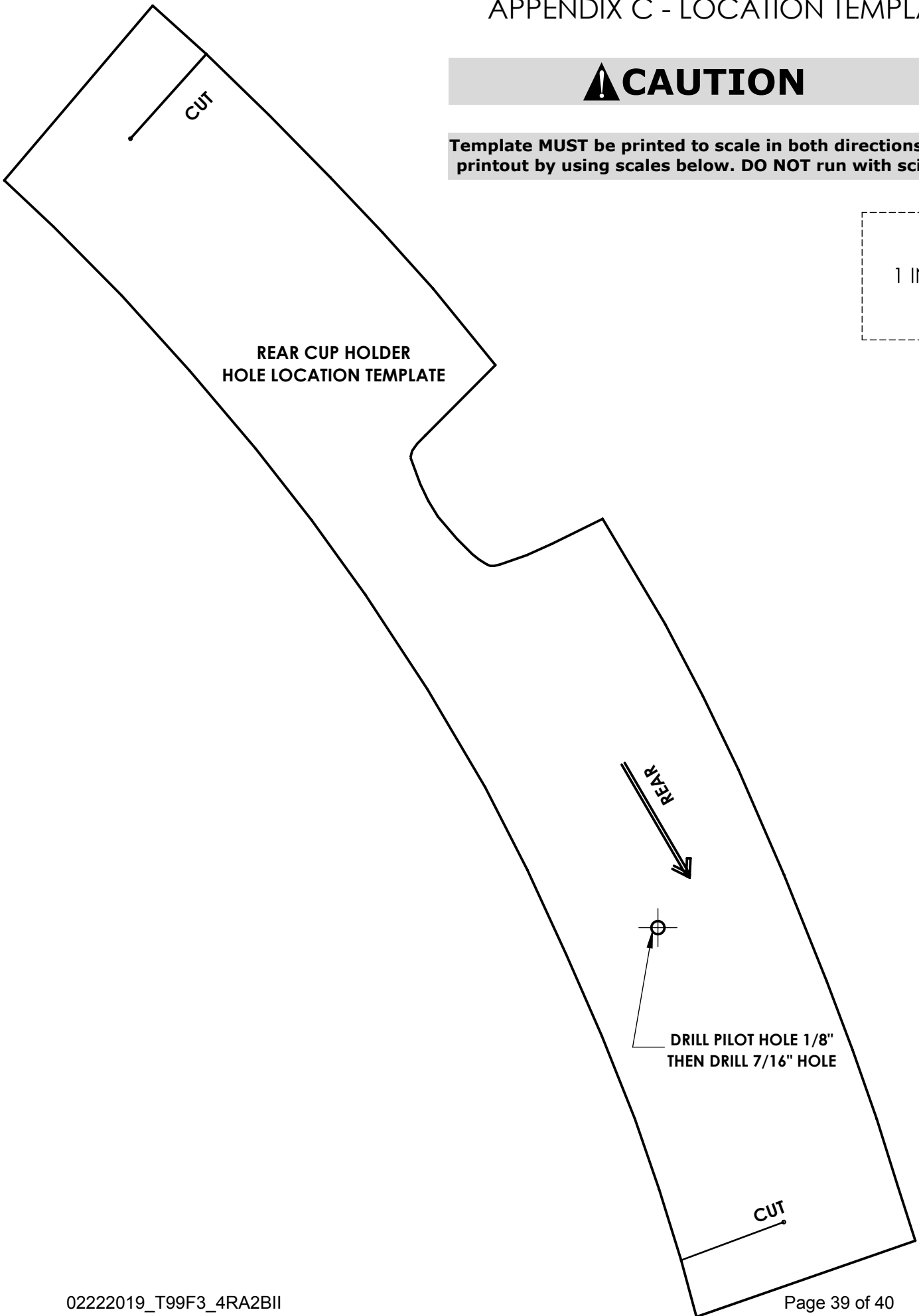
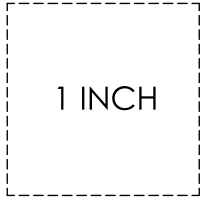

Page Intentionally Left Blank