



GENUINE PARTS

INSTALLATION INSTRUCTIONS

1. **DESCRIPTION:** Body Side Molding

2. **APPLICATION:** Sentra

3. **PART NUMBER:** 999G2 Lxxx01 – LH (xxx Designates model year and color)
999G2 Lxxx02 – RH (xxx Designates model year and color)

4. KIT CONTENTS:

	Item	Qty	Description	Part Number
Left Hand Kit	A	1	Molding – Front Door	---
	B	1	Molding – Rear Door	
	C	1	Installation Instructions	999G2 LT002II
	D	1	Template	999G2 LTTEM01
Right Hand Kit	E	1	Molding – Front Door	---
	F	1	Molding – Rear Door	
	C	1	Installation Instructions	999G2 LT002II
	D	1	Template	999G2 LTTEM01

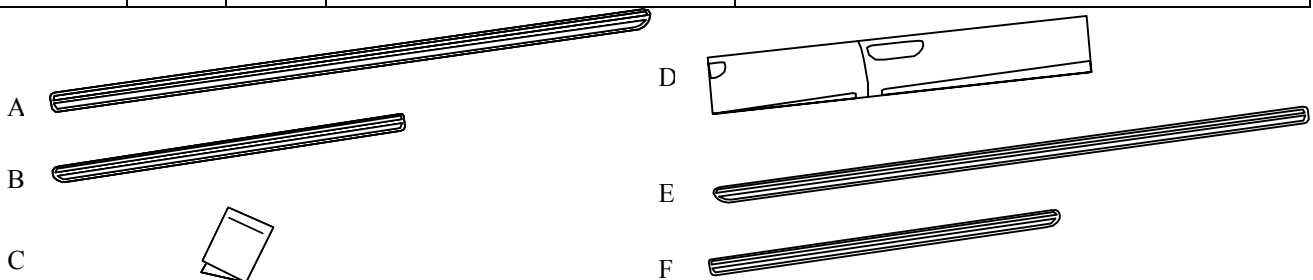

5. TOOLS REQUIRED:

- | | | |
|----------------------------------|-----------------|-------------|
| a) Clean, lint-free wiping cloth | c) Masking tape | e) Scissors |
| b) 50/50 alcohol/water solution | d) Roller | |

6. PRE-INSTALLATION CAUTIONS / NOTES:

CAUTION

- If the vehicle has recently been repainted, allow the vehicle paint to age for at least 24 hours before installing the body side moldings.
- Install the body side moldings when the ambient temperature is above 60°F (15°C).
- Do not wash or expose the vehicle to a wet environment for 24 hours after installing the body side moldings.

NOTE

- These installation instructions are for the right side of the vehicle; the same procedure applies to the left side.
- For left side installation, use the template with the text facing the vehicle.

INSTALLATION INSTRUCTIONS – Body Side Molding

7. INSTALLATION PROCEDURE:

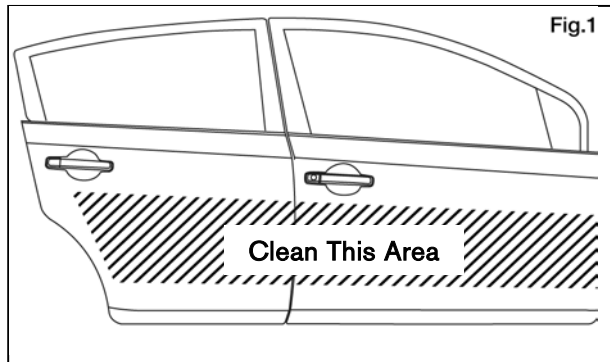

- 1) Right door template installation:
 - a) Cut out the template at areas marked "Cut Out."
 - b) With 50/50 alcohol/water solution, wipe off all dirt and oil from the front and rear doors where the template and body side moldings are to be mounted (indicated by diagonal lines). (Fig. 1) Let dry thoroughly.



CAUTION

- Failure to clean the mounting surface properly may cause the body side molding adhesive tape to have poor adhesion to the vehicle.

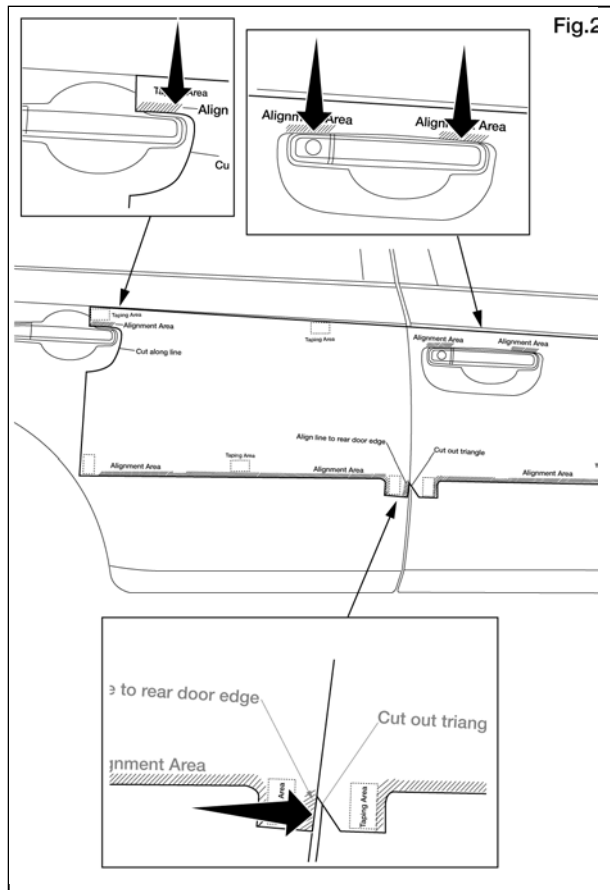

- c) Place the template on the vehicle with the text visible.
 - d) Align the edge of the template door handle cut outs to the door handles, ensuring that the front edge of the rear door aligns with the triangular cut out. (Fig. 2)

INSTALLATION INSTRUCTIONS – Body Side Molding

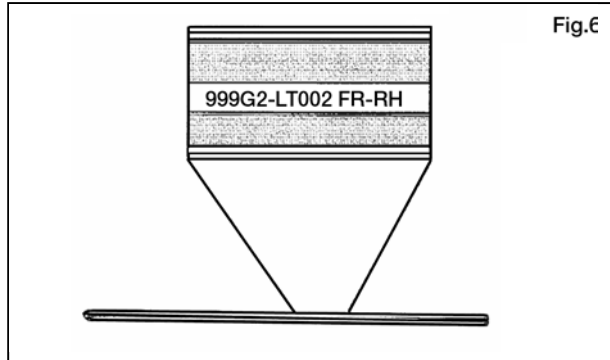

- 2) Right, front body side molding installation:
 - a) Identify the front, right body side molding. (Fig. 6)
 - b) Cut three pieces of masking tape, two inches (51 mm) long and store for use at step d).

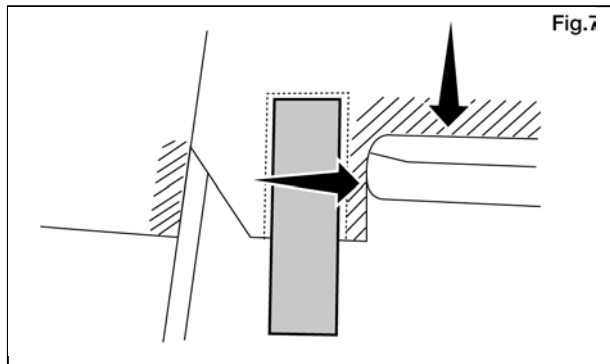

- c) Align the top and rear edges of the body side molding to the edges of the template and hold in position. (Fig. 7)

NOTE:

Be sure that the body side molding edges do not overlap the template edges.

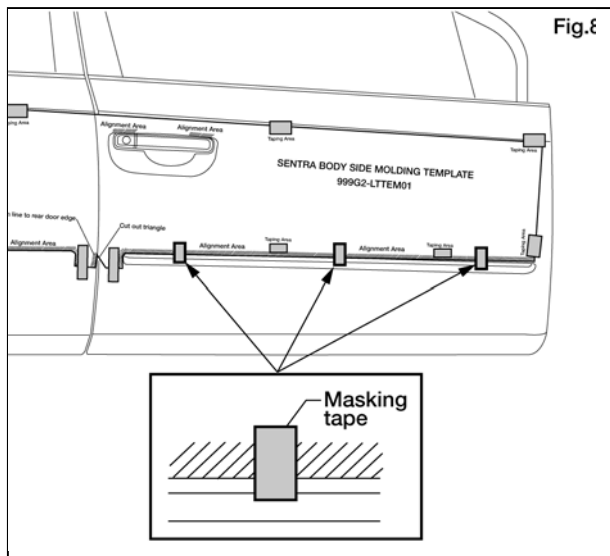

- d) While holding in position, apply three pieces of two-inch (51 mm) long masking tape to the template and body side molding at the front, middle, and rear. (Fig. 8)

NOTE:

Be sure that the body side molding edges do not overlap the template edges.

- e) Remove the body side molding lower tape liner only.
 - f) While aligning the top and rear edges of the body side molding to the edges of the template, apply 15 lbs (103 kPa) of pressure using a roller from the rear, moving forward to attach the body side molding.

INSTALLATION INSTRUCTIONS – Body Side Molding

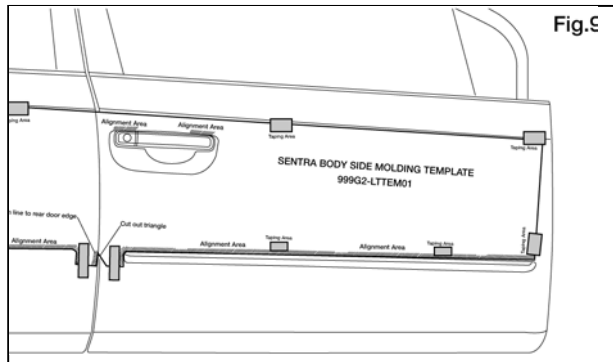

- g) Remove the three pieces of two-inch (51 mm) long masking tape from the template and body side molding at the front, middle, and rear. (Fig. 9)
- h) Slowly remove the body side molding upper tape liner and apply 15 lbs (103 kPa) of pressure using a roller from the rear, moving forward to attach the body side molding to the door.

NOTE:

Be sure that the body side molding edges do not overlap the template edges.

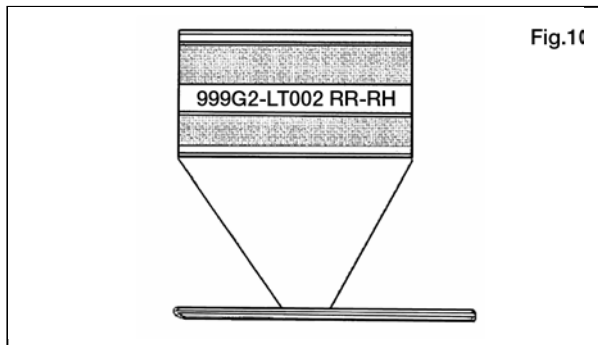

- 3) Right, rear body side molding installation:
 - a) Identify the rear, right body side molding. (Fig. 10)
 - b) Cut two pieces of masking tape, two inches (51 mm) long and store for use at step d).

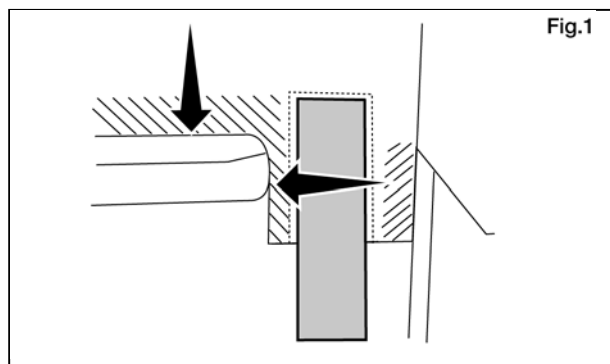

- c) Align the top and front edges of the body side molding to the edges of the template and hold in position. (Fig. 11)

NOTE:

Be sure that the body side molding edges do not overlap the template edges.

INSTALLATION INSTRUCTIONS – Body Side Molding

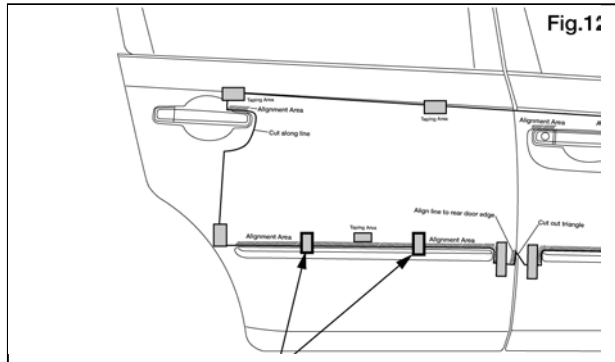

- d) While holding in position, apply two pieces of two-inch (51 mm) long masking tape to the template and body side molding at the front and rear. (Fig. 12)

NOTE:

Be sure that the body side molding edges do not overlap the template edges.

- e) Slowly remove the body side molding lower tape liner only.
f) While aligning the top and front edges of the body side molding to the edges of the template, apply 15 lbs (103 kPa) of pressure using a roller from the front, moving rearward to attach the body side molding to the door.

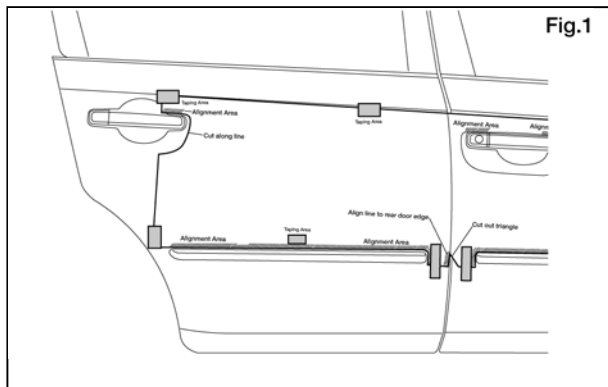

- g) Remove the two pieces of two-inch (51 mm) long masking tape from the template and body side molding at the front and rear. (Fig. 13)
h) Slowly remove all masking tape and the template from the vehicle.

NOTE:

Be sure not to damage the template during removal, as it will be required for the left side body side molding kit installation.

- i) Slowly remove the body side molding upper tape liner and apply 15 lbs (103 kPa) of pressure using a roller from the front, moving rearward to attach the body side molding to the door.

NOTE:

Be sure that the body side molding edges do not overlap the template edges.