



GENUINE PARTS

INSTALLATION INSTRUCTIONS

1. DESCRIPTION: Auto-Dimming Mirror Kit with Compass and HomeLink®

2. APPLICATION: MY07 Altima 2.5 S; 3.5 SE; 3.5 SL ; HEV

3. PART NUMBER: 999L1 UT000

4. KIT CONTENTS:

Item	Qty	Description	Service Part Number
A	1	EC Mirror	999L1 UT000S2
B	1	Parts Kit	999L1 UT000S1
C	1	Harness Assembly – Power and Ground	n/a
E	1	Wire Cover	n/a
F	5	Wire Ties, Small	n/a
G	6	Foam Tape	n/a
H	1	Installation Instructions Replacement Template	n/a
I	1	User Guide	n/a
J	1	HomeLink® Programming Instructions	n/a

5. TOOLS REQUIRED:

Clean Rag	T-20 Torx Head Driver	Panel Removal Tool	Phillip's Screwdriver
Needle Nose Pliers	4mm Flat Screwdriver	10mm Socket Wrench	

6. INSTALLATION PRECAUTIONS / NOTES:

⚠ WARNING

Disconnect vehicle battery before installing EC mirror to prevent possible shock injury during installation.

⚠ CAUTION

Place removed vehicle trim components in a clean, dry area to prevent damage

HomeLink® and the HomeLink® house are registered trademarks of Johnson Controls, Inc.

INSTALLATION INSTRUCTIONS – EC Mirror Kit (Altima)

7. INSTALLATION PROCEDURE

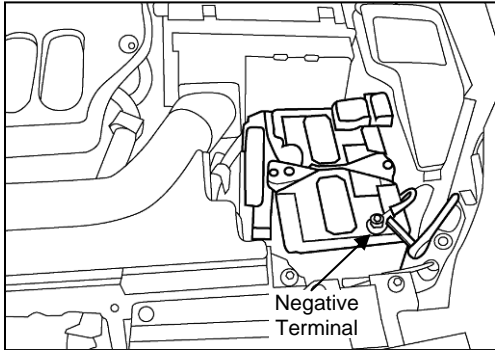

- 1) Prepare Vehicle For EC Mirror Installation
 - a) Place kit components on a clean, padded surface and inspect for damage or defects.
 - b) Record customer's programmed radio stations.
 - c) Disconnect negative battery terminal.
 - d) Set vehicle parking brake. This is to allow clearance for removal of lower dash panel.

CAUTION

Do not use excessive force when removing OE mirror from windshield. The window button may separate from windshield or the windshield could break.

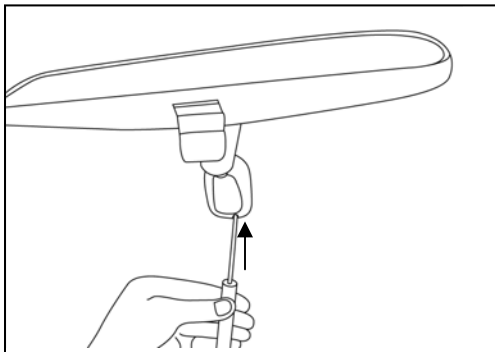

- 2) Removal of OE Rearview Mirror
 - a) Insert the flat end of a 4mm screwdriver into the opening at the bottom of the mirror mount.
 - b) Slide the screwdriver upward into the center of the mirror mount until resistance is felt. Apply a small amount of additional upward force to lift a locking spring in the mount.
 - c) While still applying upward pressure with the screwdriver, grasp the mirror bracket and lift the mirror up towards the headliner and off the mirror mounting bracket.

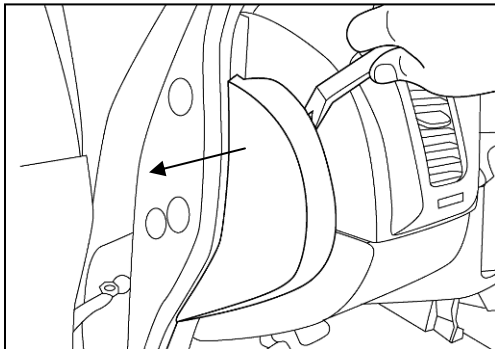

- 3) Vehicle Disassembly
 - a) Using panel removal tool, disengage clips on driver-side center dash side panel and remove.

INSTALLATION INSTRUCTIONS – EC Mirror Kit (Altima)

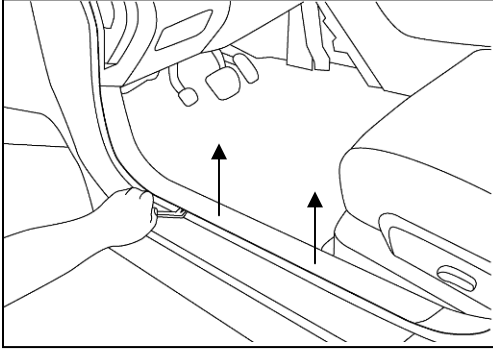

- b) Using panel removal tool, disengage clips on driver-side scuff plate and remove.

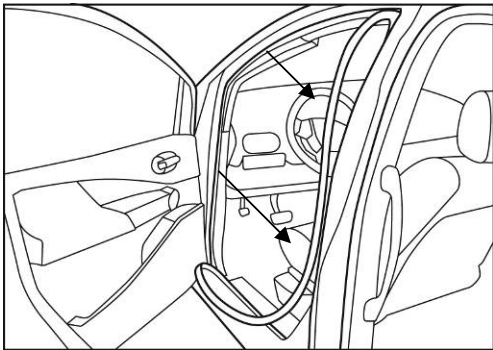

- c) Using panel removal tool, loosen driver-side weather strip and remove from top of A-pillar to scuff plate area.

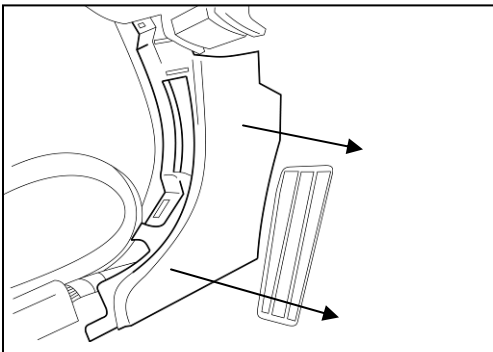

- d) Grasp driver-side cowl cover and pull towards passenger side of vehicle to remove.

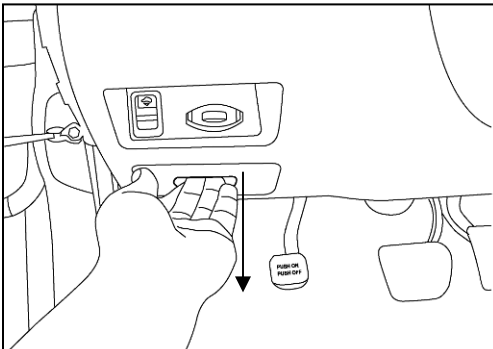

- e) Pull outward on coin tray and remove from dash panel.

INSTALLATION INSTRUCTIONS – EC Mirror Kit (Altima)

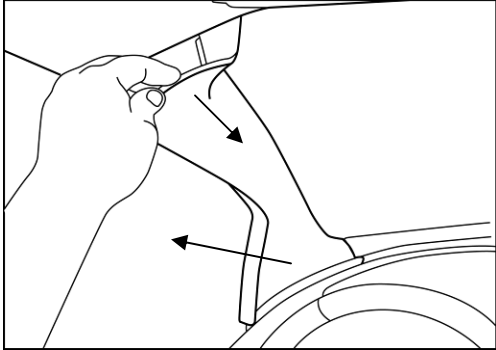

- e) Pull outward on top of driver-side A-pillar trim to disengage fasteners and then pull rearward to remove base.

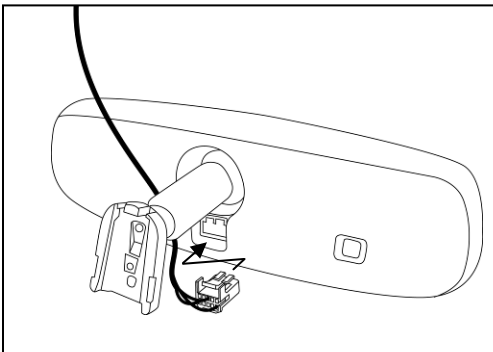

- 4) Install EC mirror
 - a) Plug the EC wire harness connector into the back of the EC mirror.

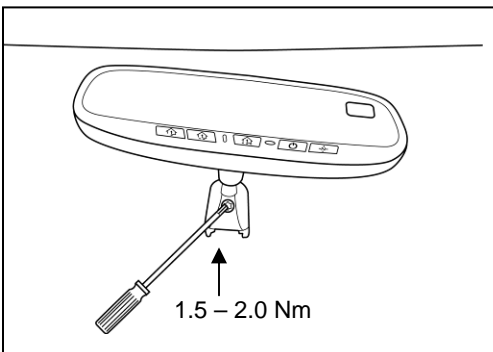

- b) Slide the EC mirror base over the button on the windshield.
- c) Using a T-20 Torx head driver, tighten the screw on the mirror mount (1.5 – 2.0 Nm)

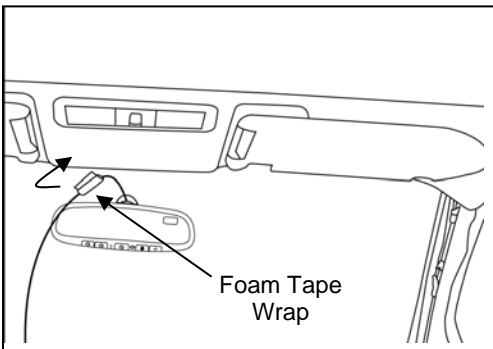

- d) Wrap one piece of foam tape around EC mirror harness and using panel removal tool, tuck between headliner and roof above EC mirror.

INSTALLATION INSTRUCTIONS – EC Mirror Kit (Altima)

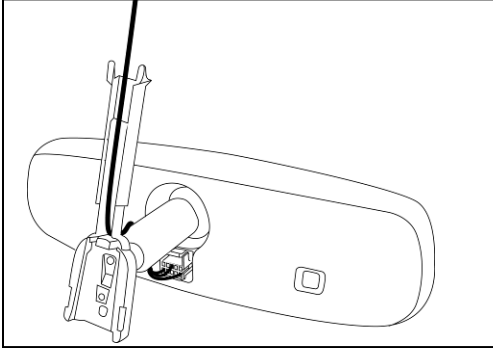

- e) Route the wire harness into the groove of the wire cover and attach to the mirror mount.
- f) Slide the forks on top of the wire cover, into the headliner.

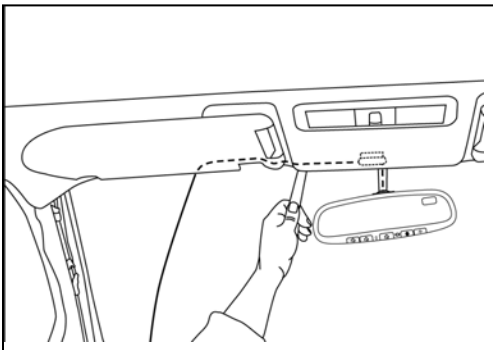

- g) Using panel removal tool, tuck the wire harness between the headliner and the roof and stop just past the visor clip.

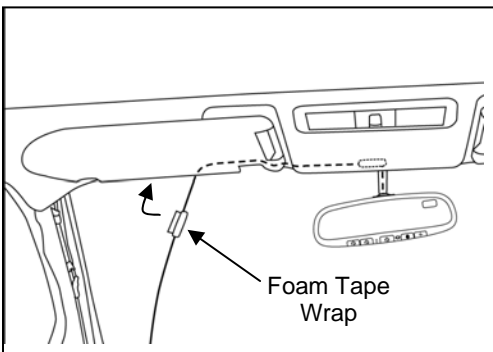

- h) Wrap one piece of foam tape around EC wire harness and tuck between headliner and roof. Taped portion of EC wire harness should be approximately centered above visor.

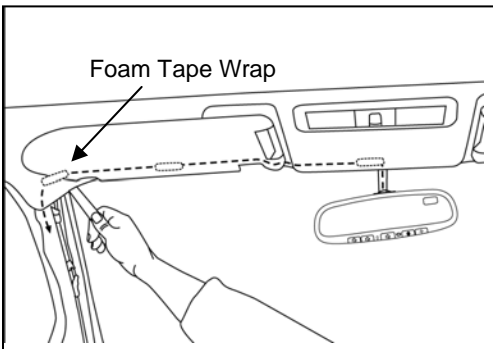

- i) Wrap one piece of foam tape around EC wire harness and tuck between headliner and roof. Taped portion of EC wire harness should be tucked at approximately where headliner bends towards driver-side door.

INSTALLATION INSTRUCTIONS – EC Mirror Kit (Altima)

CAUTION

Do not tie wrap harness to clear drain tube.

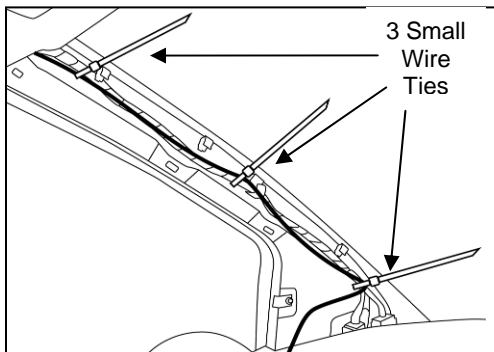

- j) Route EC mirror harness down driver-side A-pillar and secure with 3 small wire ties.

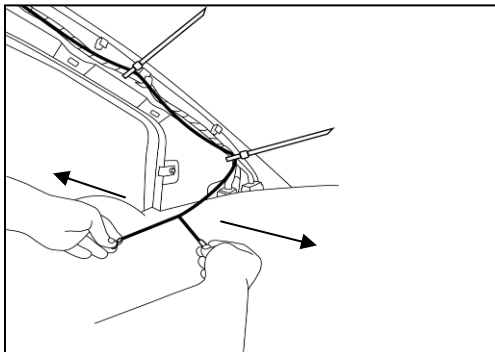

- k) Pull ends of EC harness apart approximately 40 inches.

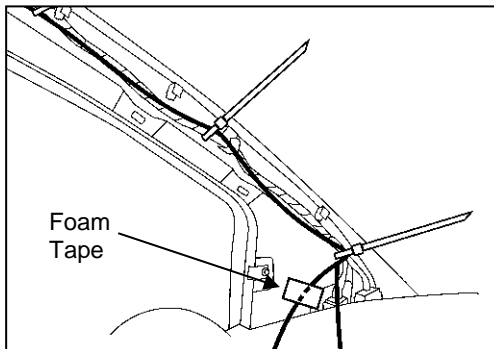

- l) Secure EC harness wire with GROUND RING at base of A-pillar with 1 piece of foam tape.

INSTALLATION INSTRUCTIONS – EC Mirror Kit (Altima)

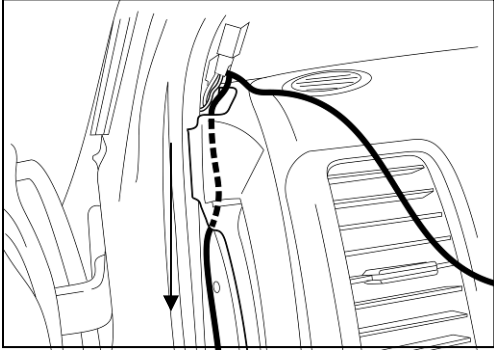

m) Route harness wire with ground ring through upper portion of dash and down along side center dash.

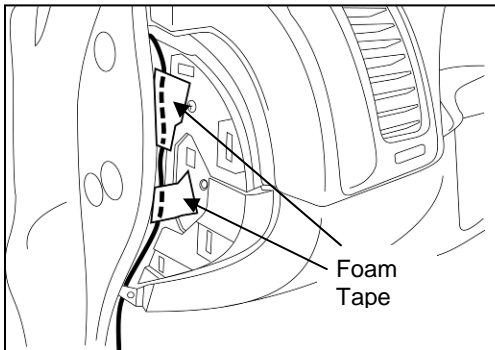

n) Continue routing harness ground ring downward along center dash and into driver-side cowl area.

o) Secure harness to side of center dash with 2 pieces of foam tape.

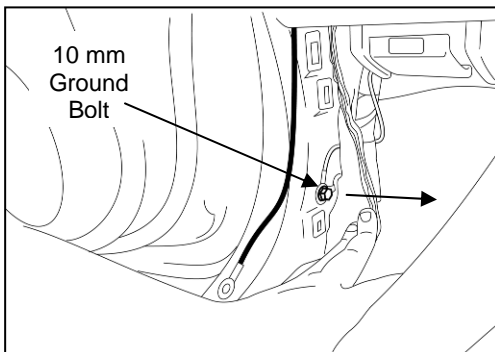

p) Locate 10mm ground bolt in driver-side cowl area (behind sound-dampening padding) and remove.

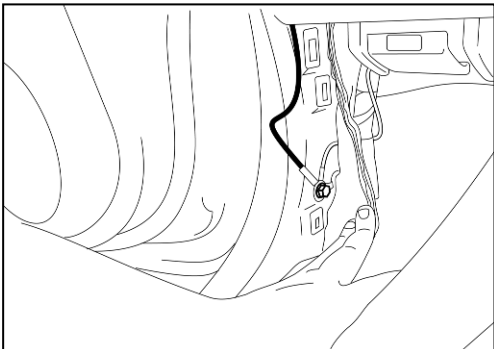

o) Install ring terminal from EC mirror harness over ground bolt and reinstall.

INSTALLATION INSTRUCTIONS – EC Mirror Kit (Altima)

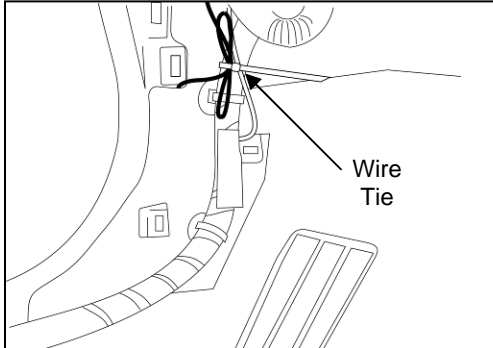

- p) Pull EC mirror harness ground wire out from behind padding (Ensure wire does not block fastener openings).
- q) Bundle excess ground wire and secure to factory wire bundle with 1 small wire tie.

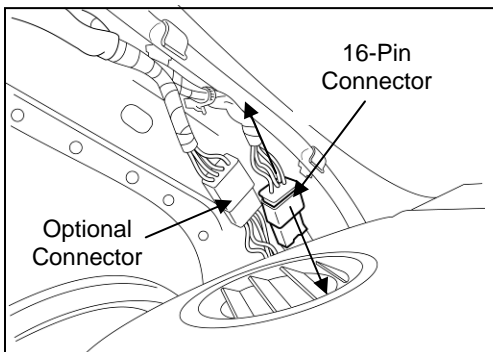

- r) Locate the 16-pin connector at base of driver-side A-pillar and unplug from mating connector.

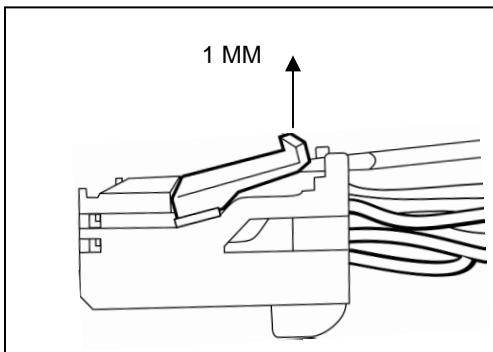

- s) Using 4mm flat screwdriver, pry the side tabs of the 16-pin connector upwards to release the locking tab (approximately 1 mm).

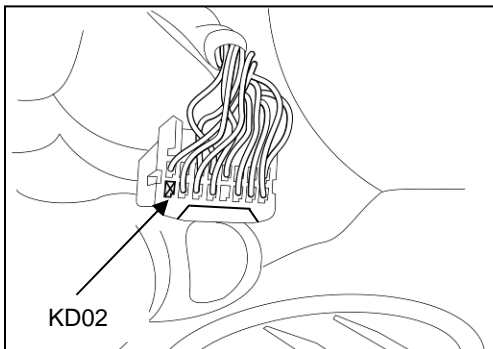

- t) Locate pin opening KD02 in the 16-pin connector.

INSTALLATION INSTRUCTIONS – EC Mirror Kit (Altima)

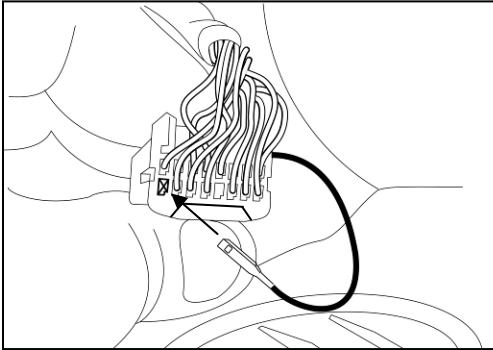

- u) Insert terminal end of EC mirror harness wire into opening KD02 of the 16-pin connector.

NOTE: Ensure terminal is locked into connector by gently pulling on wire.

- v) Press locking tab on 16-pin connector down to fully lock terminals into connector.
- w) Reinstall the 16-pin connector.

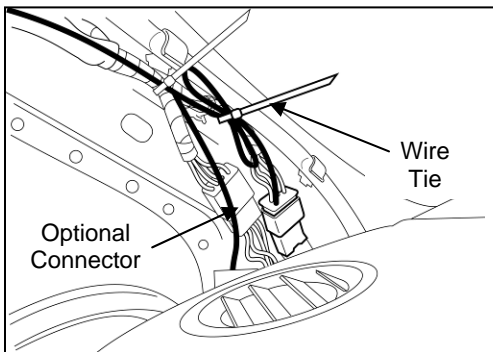

- x) Bundle excess EC mirror harness wire and secure to A-pillar wire bundle with 1 small wire tie.

WARNING

DO NOT touch the positive battery terminal with any tool when reconnecting the negative battery cable.

5) Testing

- a) Reconnect the vehicle's negative battery cable.
- b) Tighten negative battery terminal nut to 4.1 Nm.
- c) Turn the ignition switch to ON.
- d) Ensure vehicle is in a fairly well lit area.
- e) Check to see that green LED is illuminated. If it is not, press the "⏻" button to turn it on.
- f) Cover the forward-looking photocell (located below the wire harness connection on the back of the mirror) with a dark cloth or towel. After a few seconds, the mirror should begin to darken. Timing will vary with ambient light levels and a flashlight may be shined on the rearward photocell if needed, to accelerate effect.
- g) Remove the cover from the forward-looking photocell and the mirror will begin to clear.
- h) Push the "⏻" button to ensure compass display shows either a direction such as "NE" or a "C", and that it can be turned ON and OFF.

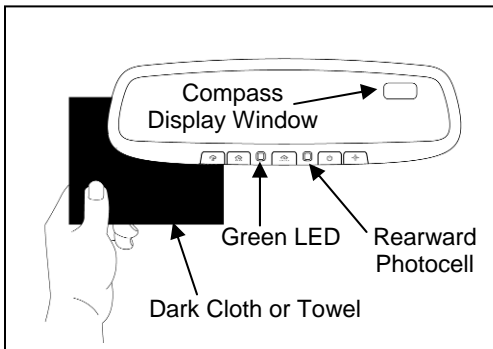

INSTALLATION INSTRUCTIONS – EC Mirror Kit (Altima)

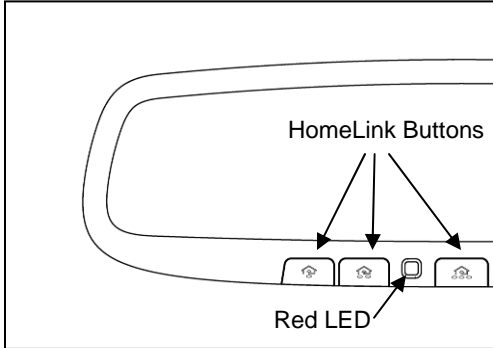

- i) Push each HomeLink[®] button, one at a time, and verify that LED indicator to the left of the center switch illuminates with a red LED.
- j) Testing is now complete.

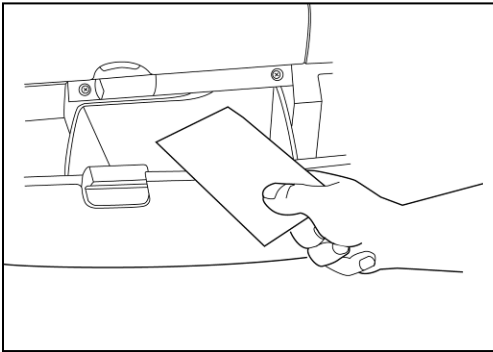

- 6) Final assembly
 - a) Trim excess material off all wire ties.
 - b) Reinstall in reverse order, all trim pieces removed during installation. **(Ensure that dash trim around gauge cluster is fully seated)**
 - c) Place the operation instruction card in the vehicle glove box.
 - d) Remove fingerprints, smudges, dirt, etc from mirror glass.
 - e) Verify each reinstalled component for proper fit and function.
 - f) Verify operation of all buttons disconnected during installation.

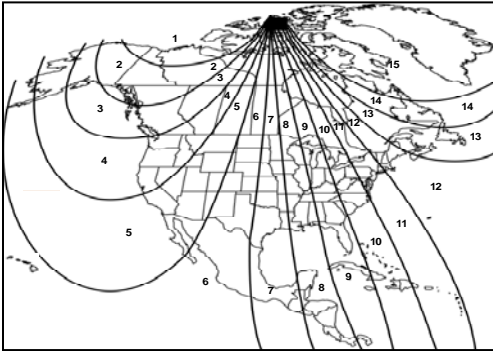

- 7) Set compass zone
 - a) With the display turned "ON," push the "⏏" button for 3 seconds, until a number appears in display (numbers correspond to regional compass zones).
 - b) Press and release "⏏" button to scroll through zone numbers.
 - c) Release "⏏" button when correct zone number is displayed. Zone number will disappear and display will return to showing either a directional heading or a "C" after 5 seconds of no switch activity.
- 8) Calibrate compass
 - a) Drive vehicle in circles (360°) at 5 mph or less until compass display window shows a direction.