



GENUINE PARTS

INSTALLATION INSTRUCTIONS

1. **DESCRIPTION:** MOONROOF WIND DEFLECTOR

2. **APPLICATION:** ALTIMA COUPE

3. **PART NUMBER:** 999D4 UU001

4. **KIT CONTENTS:**

| Item | QTY | Description |
|------|-----|-----------------------------------|
| A | 1 | Moonroof Deflector |
| B | 3 | Phillips Head Screw (16mm length) |
| C | 3 | Nylon Washers |
| D | 3 | Nylon Nuts |
| E | 2 | Side Brackets |
| F | 1 | Center Bracket |
| G | 3 | Protective Tape |

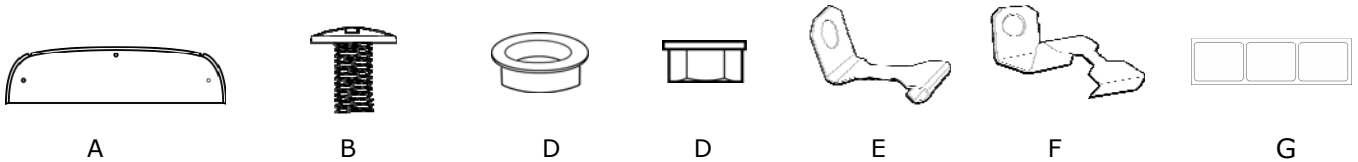

5. **TOOLS REQUIRED:**

- Car Wash Supplies
- Felt Tip Pen
- Shop Towel
- Phillips Head Screw Driver
- Measuring Tape
- Rubbing Alcohol
- 10mm Wrench
- Masking Tape

6. **CAUTIONS/NOTES:**

- To avoid damaging the surface, never use ammonia-based cleaners or solvents to clean your moonroof deflector.
- Clean moonroof deflector with a solution of mild dishwashing soap and water using a soft cloth or chamois.
- To remove fine scratches and restore the original luster, use a high quality plastic cleaner.

INSTALLATION INSTRUCTIONS - MOONROOF WIND DEFLECTOR

7. INSTALLATION PROCEDURE:

1) Preparation

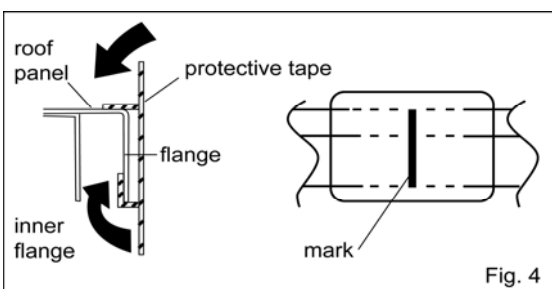
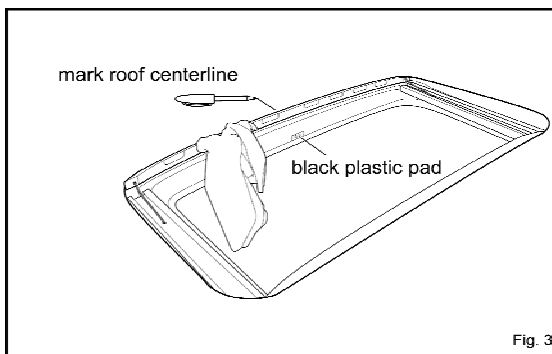
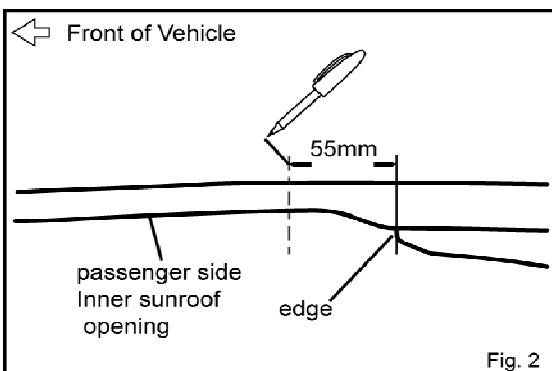
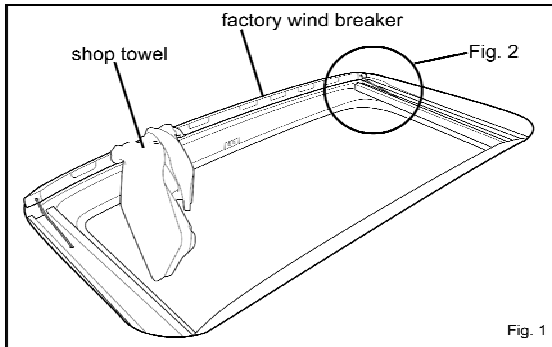

- a) Open the moonroof.
- b) Clean the roof installation area.
- c) Clean the inner edge (flange) of the moonroof opening using rubbing alcohol and a shop towel.
- d) Push the factory wind breaker down and insert shop towel (Fig1) to hold it in place.
- e) Measure 55mm forward from the edge shown in Fig.2, and mark the location on the flange. Repeat for driver side.
- f) Mark the roof centerline on the flange using the black plastic pad on the headliner (Fig 3) for reference.
- g) Attach a piece of protective tape to the roof at each of the marked locations using the marks as centerlines. Wrap the protective tape around the bottom of the sheet metal flange, making sure it does not contact the inner sheet metal flange (Fig 4).
Note: It is helpful to use one of the brackets to push the tape if it is interfering with the inner flange.
- h) Center the brackets over the protective tape and temporarily secure each bracket in place using masking tape.

INSTALLATION INSTRUCTIONS - MOONROOF WIND DEFLECTOR

7. INSTALLATION PROCEDURE (CONTINUED):

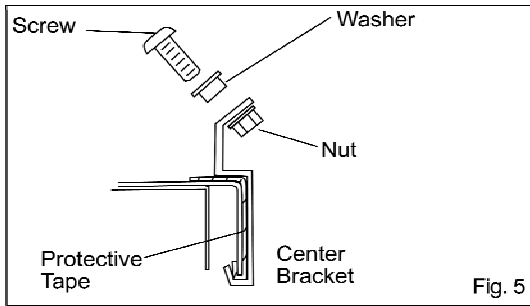

2) Installation

- i) Set the moonroof deflector on the roof so the deflector holes are aligned with the bracket holes.
- j) Starting with the center bracket, install the washer and screw through the deflector and the bracket and loosely tighten the nut. (Fig 5)

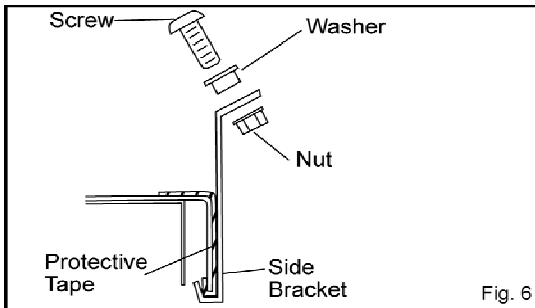

- k) Repeat for both side brackets. (Fig 6)

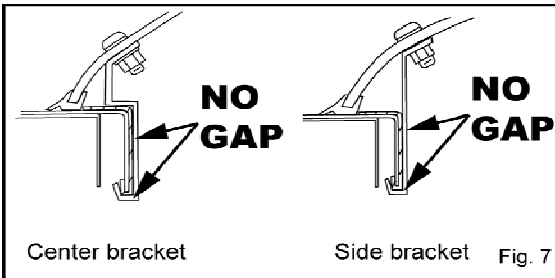

- l) Remove the masking tape holding the brackets in place.
- m) Push the deflector forward to eliminate any gaps between the brackets and the sheet metal and position the moonroof deflector with equal spacing on all sides."

CAUTION

- **CONFIRM THERE IS NO CLEARANCE/GAP BETWEEN THE BRACKET AND THE VEHICLE. IF THERE IS A GAP, ADJUST DEFLECTOR AND SIDE BRACKETS FORWARD TO ELIMINATE GAP. (Fig 7)**

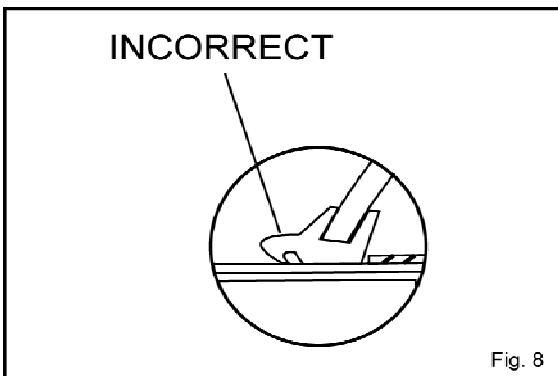

- n) Check that the rubber seal is not twisted or rolled under the deflector (Fig 8). If necessary slide a credit card under the deflector from the back side to straighten the gasket.

- o) Tighten the center bracket nut. Adjust the outer brackets as necessary and tighten side bracket nuts. To prevent damage to the nylon nuts, do not overtighten.

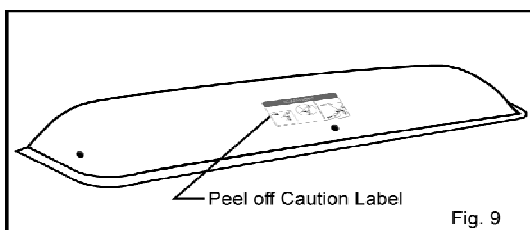

- p) Remove the shop towel holding the factory wind breaker down and close the sunroof.
- q) Remove and discard the "Caution Label" attached to the top surface of the deflector (Fig 9).