



GENUINE PARTS

INSTALLATION INSTRUCTIONS

DESCRIPTION: Vehicle Tracking and Recovery System

APPLICATION: Rogue (2008)

PART NUMBER: 999Q8 VW000

KIT CONTENTS:

Item	Qty.	Part Description	Service Part Number
A	1	GPS Control Module	99Q8 VW000S1
B	1	Wire Harness	99Q8 VW000S2
C	1	I/I Download Instructions	999V2 AW000
D	1	Owners Manual	
E	1	Activation Card (included in owners manual)	
F	8	6" Cable Ties	
G	2	12" Cable Ties	
H	1	Foam Pad (on module)	
I	10	Foam Tape	
J	2	Posi-Taps	999M1 VT000
K	1	Mirror Hanger (Nissan VTRS information)	
L	1	Alcohol wipe	



A



B

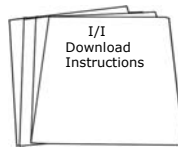

C



D



E



F



G

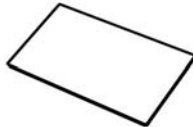

H

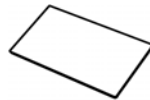

I

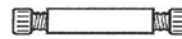

J



K

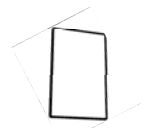

L

TOOLS REQUIRED:

- Ratchet
- 10mm socket
- #2 Phillips screwdriver
- Plastic pry bar
- Wire cutter

PRE-INSTALLATION WARNINGS, CAUTIONS, CRITICAL STEPS, and NOTES:

- Dealer Installation Recommended. Instructions may refer to service manual.
- This part is to be installed at a surface temperature of 65-100°F.
- Posi-Tap instructions must be followed exactly as described in this instruction

INSTALLATION OVERVIEW:

System Block Diagram

Fig.1

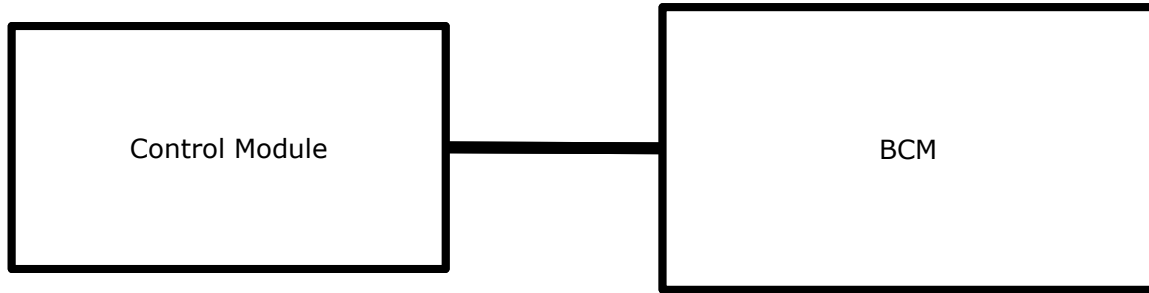

Vehicle outline with installation overview

Fig.2

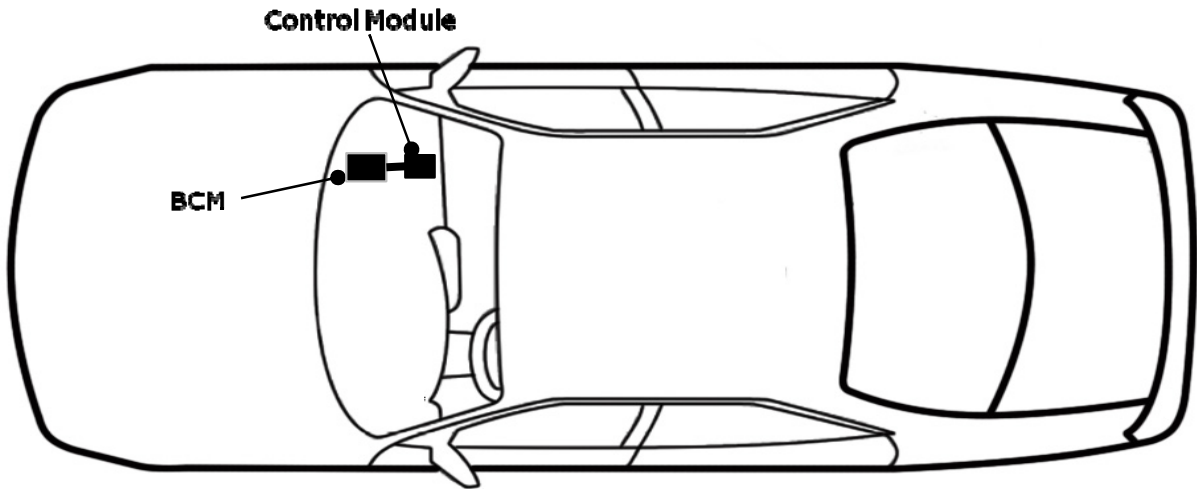

INSTALLATION PROCEDURE:

- 1) Apply parking brake
- 2) Turn ignition switch to "ON" position
- 3) Record the customer radio presets and other presets as required

Preset	1	2	3	4	5	6	7	

- 4) Put the shift lever in "P" position for A/T or "1st" for M/T
- 5) Turn the ignition switch to "OFF" position

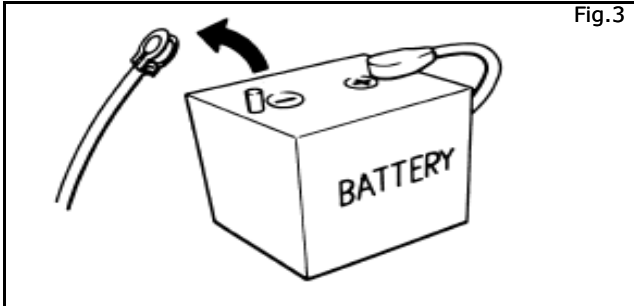

- 6) Disconnect the negative battery terminal

⚠ CAUTION

- Take care not to scratch or damage any component during the removal or re-installation process.
- Trim pieces found to have witness marks or broken clips are not to be reinstalled.

- 7) Remove the following vehicle parts in the sequence shown below. Store these re-usable parts in a safe and protected manner.

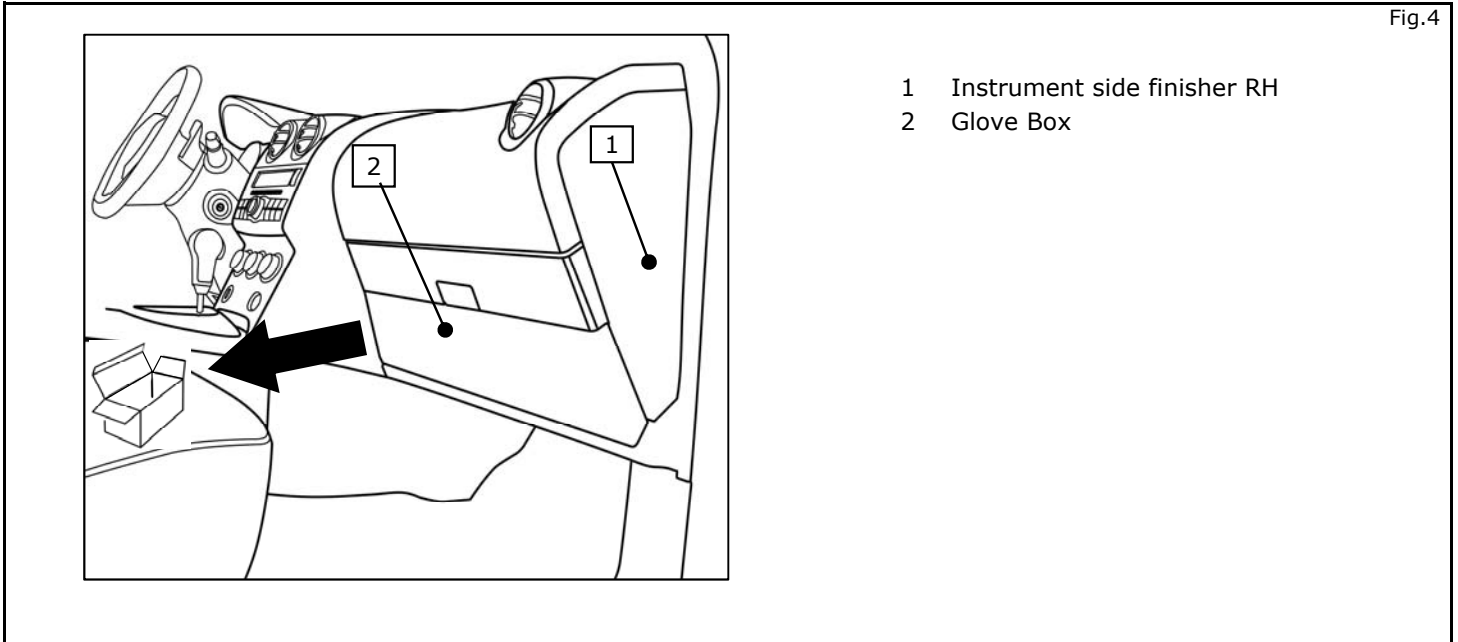

INSTALLATION PROCEDURE:

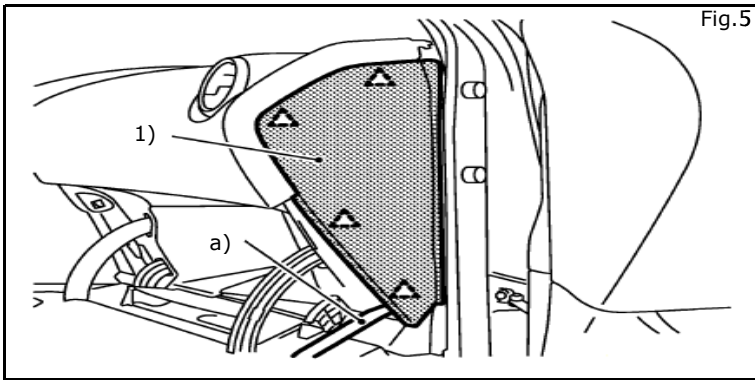

- 8) Remove instrument side finisher RH
 - a) Insert panel trim removal tool into low space instrument side finisher RH (1) fixing pawls
 - b) Pull back on instrument side finisher

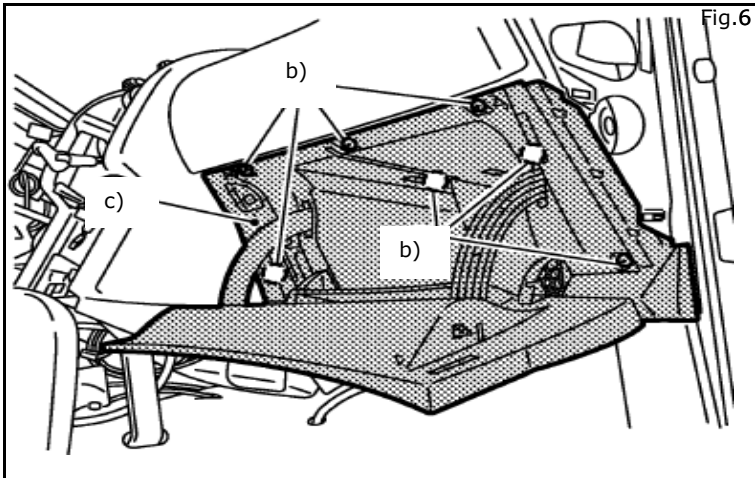

- 9) Remove glove box assembly
 - a) Open the glove box lid
 - b) Remove (7) phillips screws
 - c) Pull glove box assembly
 - d) Disconnect glove box lamp harness connector

- 10) Remove the BCM
 - a) Remove (4) Phillips screws from the BCM mounting bracket.

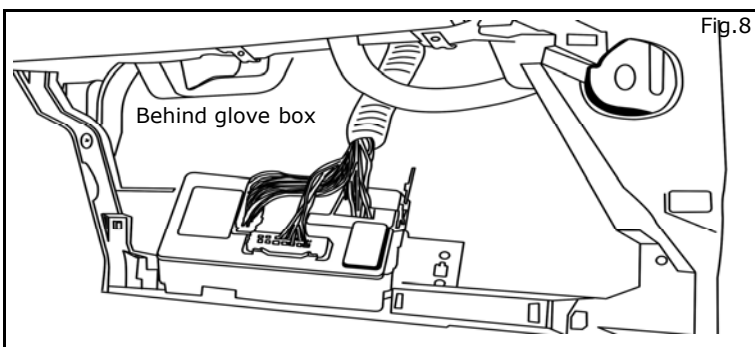
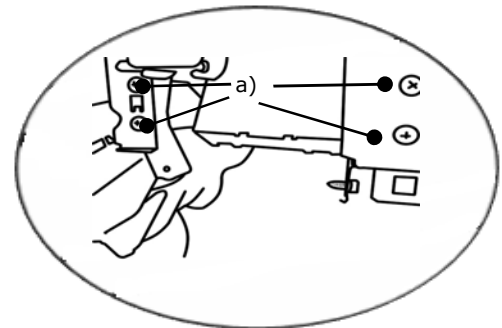
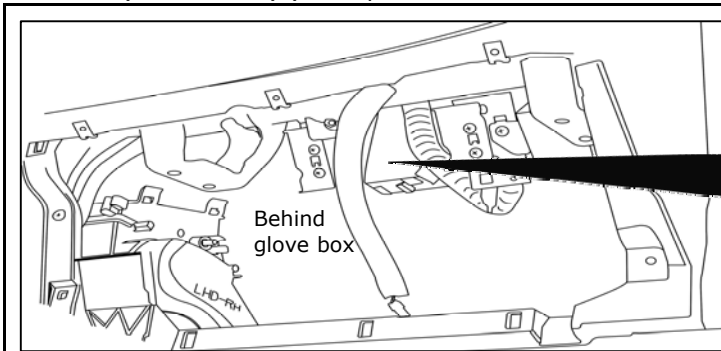

- b) Position BCM to expose wiring

INSTALLATION PROCEDURE:

⚠ CAUTION

- Color(s) given in illustration(s) are for reference only. Use location(s) where color deviates.
- If a vehicle wire is being used by another accessory and a posi-Tap is present, tap the accessory wire not the vehicle wire

11) Tap the Vehicle Tracking and Recovery System Red wire to the vehicle Dark Green B+ wire.

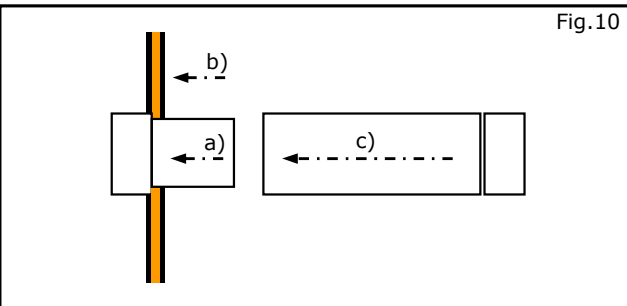
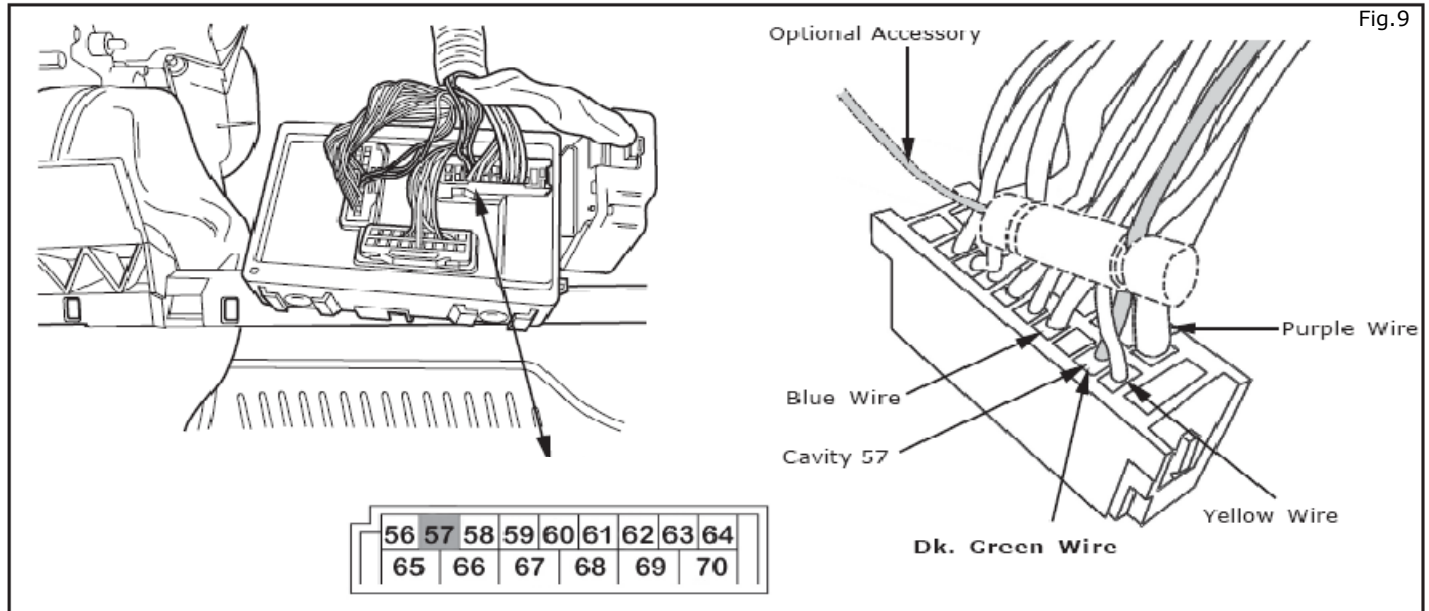

- 12) Tap vehicle wire.
- Remove cap (slot side) from the tap body
 - Slide cap around vehicle wire.
 - Tighten the tap **TIGHT** with finger pressure.

NOTE:
Do not re-use the tap for subsequent re-installation. Figures are not to scale.

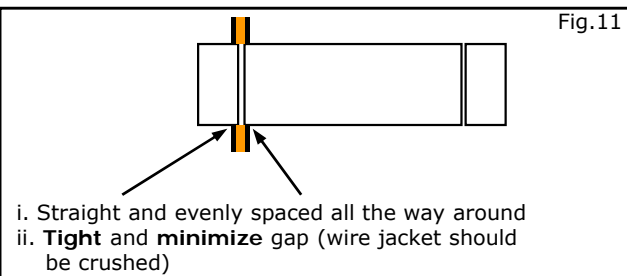

- 13) Inspect the tap to ensure correct installation.

NOTE:
Avoid putting pressure on the vehicle wire and tap for the remainder of the installation.

INSTALLATION PROCEDURE:

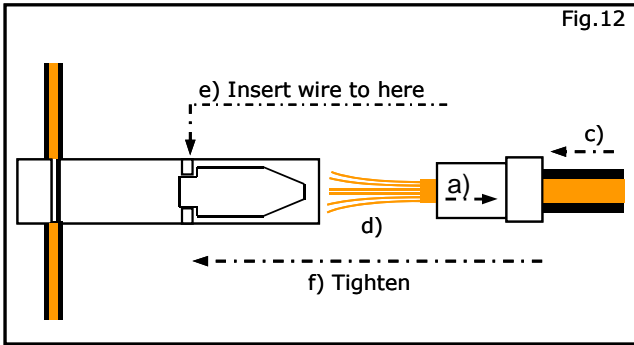

- 14) Tap accessory wire.
- a) Remove tap (non-pierce) side from tap.
 - b) Remove the protective stub from the wire.
 - c) Insert wire through the non-pierce side opening.
 - d) Spread the individual strands into fan shape.
 - e) Insert wire into the tap body and ensure that it is all the way in.
 - f) Tighten the tap **TIGHT** with finger pressure.

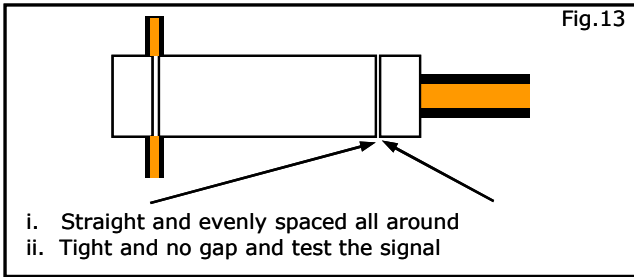

- 15) Confirm the tapped accessory wire.
- a) Inspect the tap to ensure correct installation.
 - b) Test the signal to ensure that it is working properly.

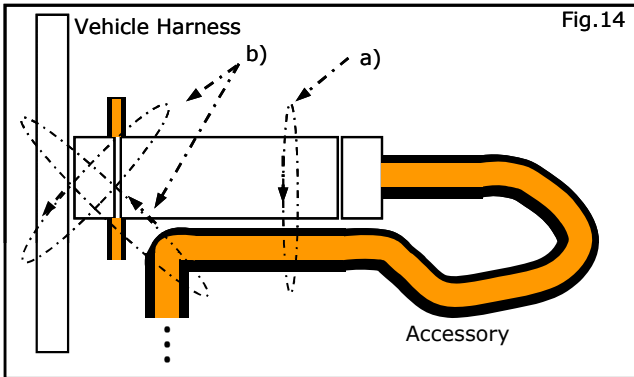

- 16) Secure the tap.
- a) Secure the tapped wire on the non-pierce side to the body of the tap with electrical tape (≥ 2 revolutions).
 - b) Secure the body to harness where vehicle wire is being tapped with electrical tape (≥ 2 revolutions).

17) Tap the Vehicle Tracking and Recovery System Brown wire to the vehicle Sky Blue ACC wire.
See steps 12-16 for wire tap installation instructions.

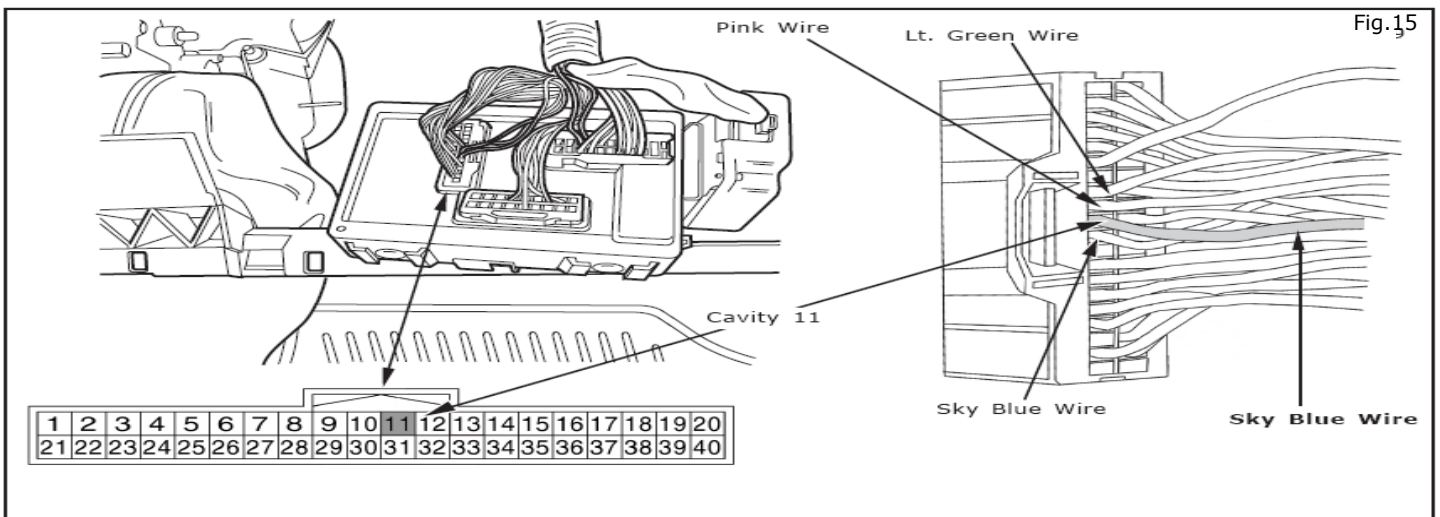

INSTALLATION PROCEDURE:

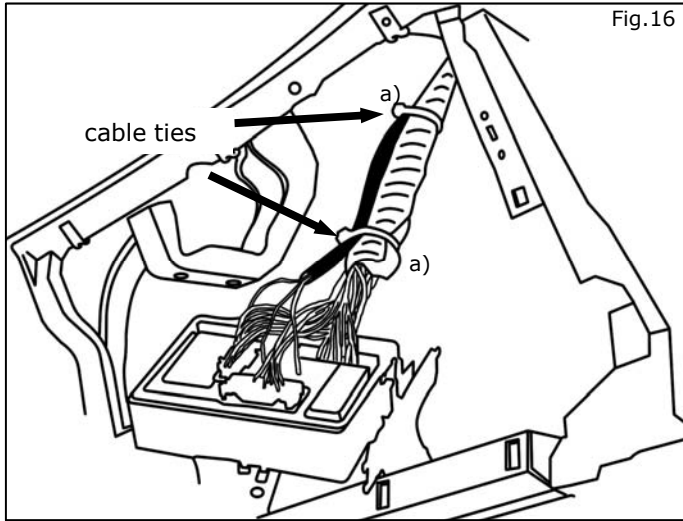

18) Attach Harness

- a) Install cable ties around Vehicle Tracking and Recovery System harness and the BCM harness.

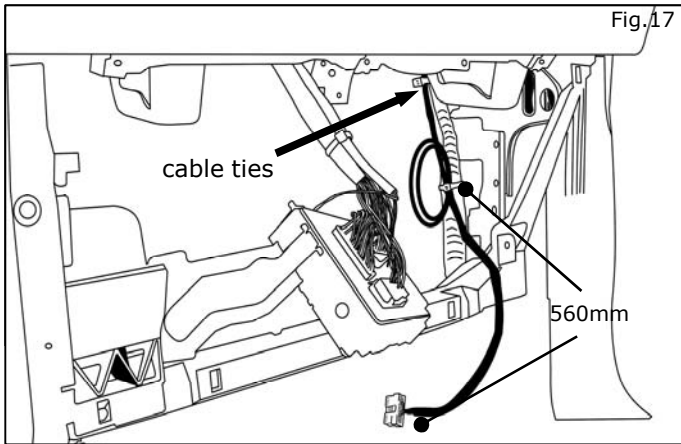

- b) Secure harness with cable tie with 560mm service loop from GPS Tracking Connector

INSTALLATION PROCEDURE:

⚠ CAUTION

- When stacking multiple ground eyelets, **DO NOT** stack the stems of the eyelet
- When stacking multiple ground eyelets, leave a 30° spacing between the stems of the eyelet

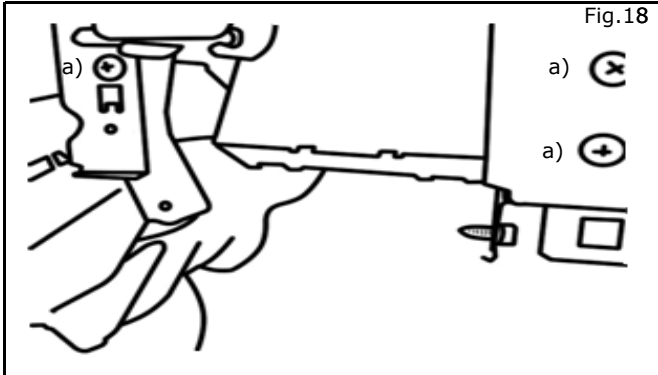

- 19) Re-attach the BCM
a) Re-Install (3) phillips screws.

- b) Install Ground eyelet under (1) remaining screw

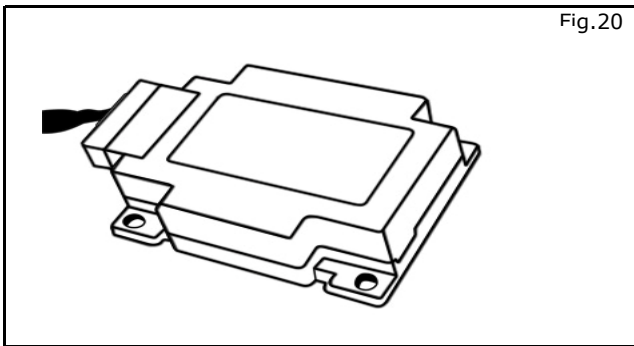
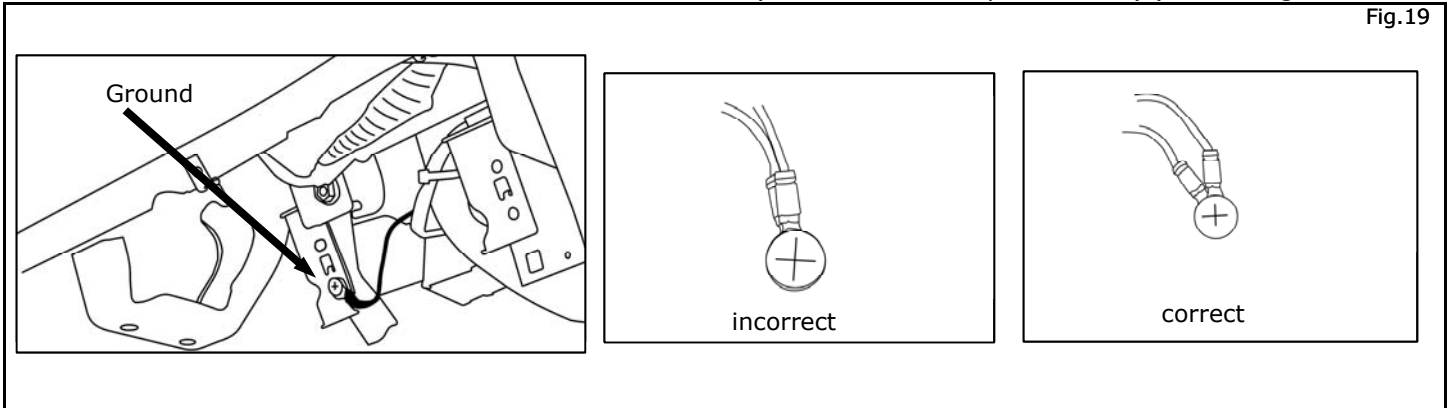

- 20) Connect the harness to the control module

ACCESSORY CHECK:

- Connect all harness connections (without re-assembly)
- Connect the battery negative terminal..
- Check all **Critical Installation Steps**.
- Verify all wiring is secure and not exposed.
- Trim all excess cable ties flush.
- Verify the Control Module Diagnostic L.E.D.'s are blinking Green
- Verify proper Diagnostic L.E.D. blinking pattern (without engine start)
 - Turn ignition switch to "OFF: position, the Green L.E.D. will blink bright once every three seconds
 - Turn ignition switch to "ON" position for ten seconds, the Green L.E.D. will continue to blink bright once every three seconds
 - Turn ignition switch to "OFF" position, the Green L.E.D. will be dim and blink once every three seconds
- Secure mirror hanger to rear view mirror
- Disconnect the negative battery terminal

INSTALLATION PROCEDURE:

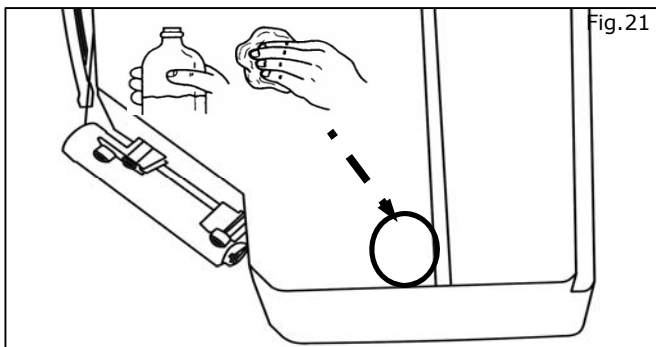

- 21) Mount Module.
- a) Clean installation surface with $\geq 90\%$ alcohol/water solution.
 - b) Peel tape liner from foam pad on Module

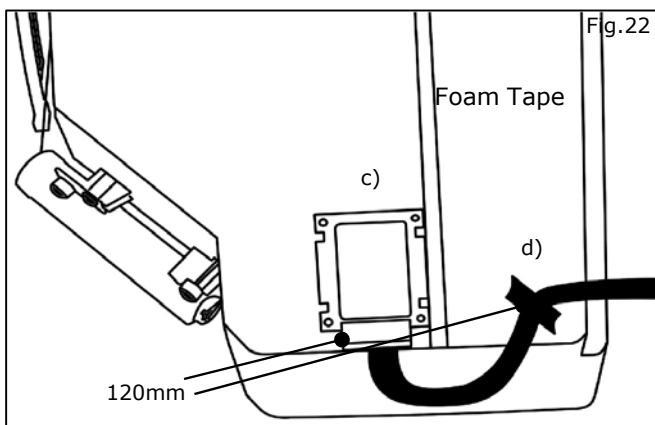

- c) Adhere module to top of glove box
- d) Secure harness to glove box with foam tape 120mm from connector

RE-INSTALLATION OF REMOVED PARTS:

22) Re-install all removed vehicle parts. Refer to the vehicle service manual for more details.



CAUTION

Use caution when re-installing interior components to avoid damage, scratches, or breaking of mounting clips. Refer to the vehicle service manual for more information.

FINAL INSPECTION:

- Verify re-installed trim parts for proper flush fit (no gap, no waviness, etc.).
- Verify all clips are fully engaged and locked.
- Verify re-installed trim parts are free from cracks, scratches or stress marks.
- Verify vehicle headliner, seat, steering wheel, center console, floor carpets, etc. are not soiled.
- Verify interior and exterior is not damaged.
- Connect the battery negative terminal and tighten the nut to appropriate torque.
- Turn ignition switch to "ON" and confirm proper operation of Vehicle Systems
 - If equipped, verify all window and sunroof one touch operation and perform the reset procedure if necessary. Refer to the vehicle service manual for more details.
 - Confirm proper audio function (AM, FM, SAT, CD and AUX).
- Re-program radio presets and other vehicle settings to the recorded settings.
- Start engine and verify that there are no new Diagnostic Trouble Codes. Turn ignition switch to "OFF".
- Place the Owner Manual, Quick Reference Guide, and/or other Manual in the glove box.

Posi-Tap™ is protected by patent # 5,228,875 5,695,369 5,868,589 6,692,313 Jap 2881414 Aus 708700 Tia 103534
Can 2204826 Mex 200626 Korea 477279 China Z197105562.9 & others pending.