



GENUINE PARTS

INSTALLATION INSTRUCTIONS

1. **DESCRIPTION:** Cargo Organizer

2. **APPLICATION:** Leaf

3. **PART NUMBER:** 999C2 8X000

4. **KIT CONTENTS:**

Item	Qty.	Description	Part Number
A	1	Cargo Organizer	999C2 8X000
B	1	Jack nut	
C	1	Jack nut install tool	
D	1	Bolt	
E	1	Knob	
F	2	Divider	

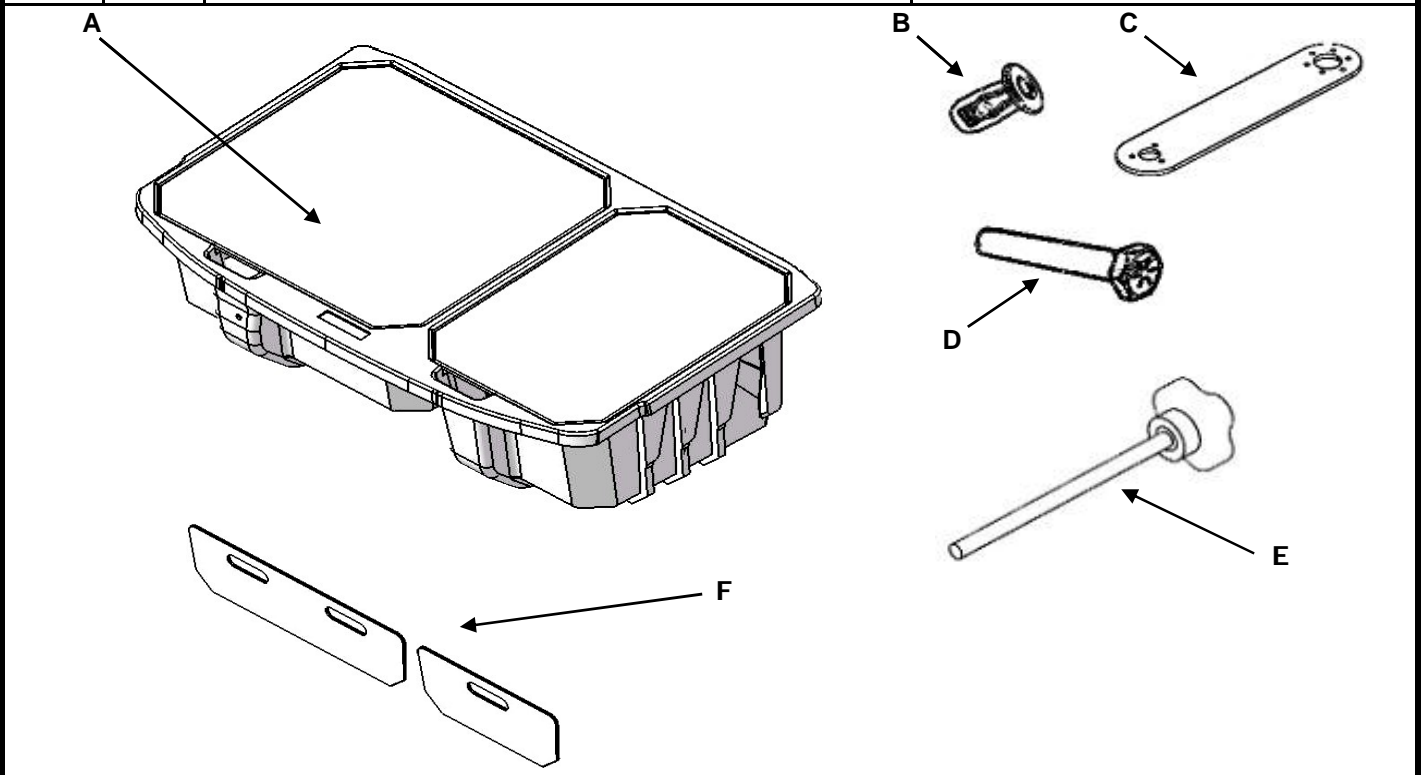

5. **TOOLS REQUIRED:**

- 5/16" wrench
- Drill and 3/8" bit
- Plastic clip pry tool

6. **PRE-INSTALLATION CAUTIONS/NOTES:**

To maintain the luster of the plastic bin in your organizer, clean with a cloth as required using standard automotive vinyl, leather and upholstery cleaners or soap and water.

INSTALLATION INSTRUCTIONS - Cargo Organizer

⚠ WARNING

- Your cargo organizer is designed to transport normal cargo contents. Flammable or dangerous materials should not be transported in your vehicle at any time. If any corrosive chemicals are spilled in your organizer it should be cleaned as described above.
- Care should be taken to avoid damaging the interior panels while installing or removing the organizer. Do not use sharp tools to remove trim or weatherseal.
- Do not over tighten the hand knob

⚠ CAUTION

- Organizer does not provide load restraint.
- Maximum load of 150lbs (68Kg).

7. INSTALLATION PROCEDURE:

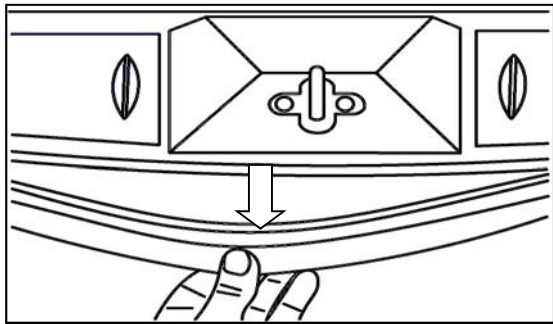

Figure 1

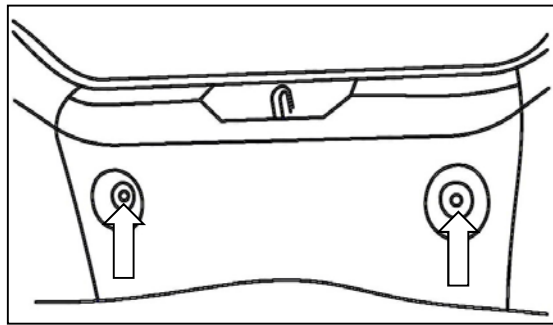

Figure 2

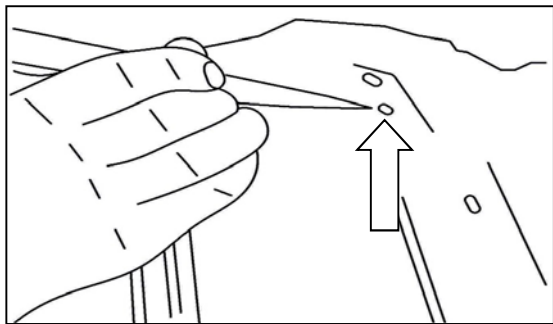

Figure 3

1. Remove the parcel shelf and any cargo, including the charge kit, from space behind rear seats. Taking care not to damage the interior panels, gently pull the weatherseal away from the rear plastic trim plate.

See Figure 1

- ⚠ CAUTION:** Care should be taken to avoid damaging the interior panels while installing or removing the organizer. Do not use sharp tools to remove trim or weatherseal.

2. Remove the load floor cover from the cargo area. Carefully pry the 2 (two) plastic trim clips out of the rear trim sill. **See Figure 2.** Using the pry tool, pull the rear trim up to disengage 4 clips (2 per side), then lift and remove the trim.

3. Drill out the **driver side** hole where the plastic trim clip was located using a 3/8" bit. **See Figure 3.**

INSTALLATION INSTRUCTIONS - Cargo Organizer

7. INSTALLATION PROCEDURE:

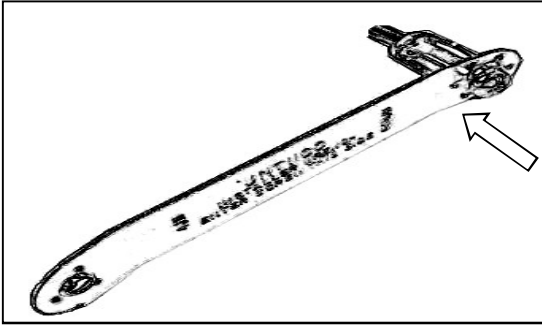

Figure 4

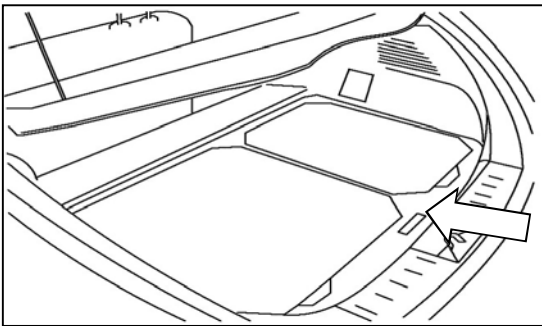

Figure 5

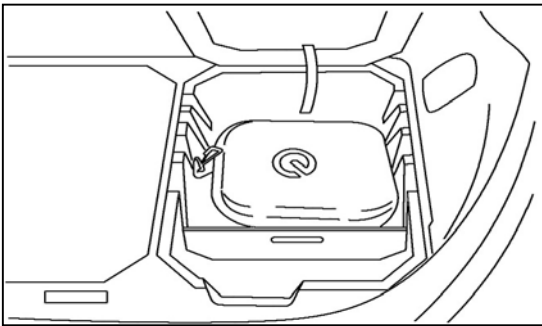

Figure 6

4. Place the bolt through the hole in the jack nut installation tool. Thread the jack nut on the bolt up to the tool. **See Figure 4**
5. Push the jack nut into the **driver side** hole where the plastic trim clip was located and, applying constant pressure to keep the nut against the sheet metal, turn the bolt with the wrench to collapse the nut. Once the nut is collapsed and secure from spinning unscrew the bolt.
6. Reinstall the rear trim sill and push one of the plastic trim clips in the passenger side hole to secure it. If both of the trim clips were damaged during removal, use an appropriate replacement. Reinstall the weatherseal and load floor.
7. Place a cover sheet or rag over the trim to protect it and slide the organizer into the rear well .
See Figure 5
8. Once down in the well, remove the trim protection, pull the organizer rearward and align the knob stud with the trim and jack nut hole. Thread the knob into the jack nut until the rear wall of the organizer just touches the plastic rear sill.
Reinstall the parcel shelf (if applicable).

⚠ CAUTION: Do not over tighten the knob
Maximum load of 150lbs (68Kg)

9. Store the charge kit in the small bin.
See Figure 6