



GENUINE PARTS

INSTALLATION INSTRUCTIONS

1. **DESCRIPTION:** Fog Lamp
2. **APPLICATION:** Cube
3. **PART NUMBER:** B61E0-1FC00 (With auto light)
B61E0-1FC01 (Without auto light)

4. **KIT CONTENTS:**

Item	QTY	Description
A	2	Fog lamp
B	2	Bolt
C	1	Combination Switch (With auto light) (Without auto light)
D	1	Installation/handling manual

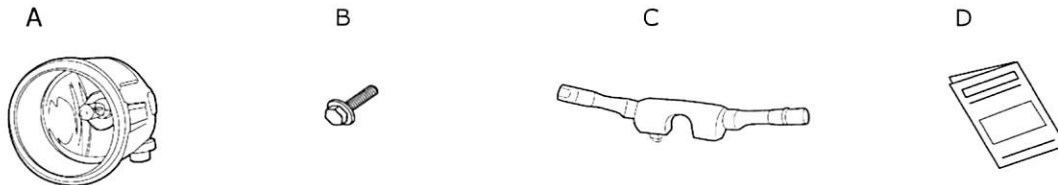

5. **TOOLS REQUIRED:**

- Clip clamp tool 
- Torque wrench
- Socket wrench (8mm), (10mm)
- Phillips screwdriver ⊕
- Masking tape

6. **PRE-INSTALLATION CAUTIONS/NOTES:**

CAUTION

- Care must be taken not to scratch or damage any components during the removal or replacement process.

NOTE:

- **Dealer Installation Recommended. Instructions refer to Service Manual.**
- **Use caution when removing trim parts to avoid breaking clips.**

- 1) Apply Parking Brake.
- 2) Make sure the shift lever is engaged in "P" or "N" position.
- 3) Record customer Radio Presets.

Preset	1	2	3	4	5	6
A						
B						
C						

- 4) Use seat and floor protection.
- 5) Open the hood of the vehicle.
- 6) Disconnect the negative battery terminal to prevent short circuits during installation.
- 7) This part is to be installed at a vehicle body surface temperature of 65-100°F.

INSTALLATION INSTRUCTIONS - Fog Lamp

7. INSTALLATION PROCEDURE:

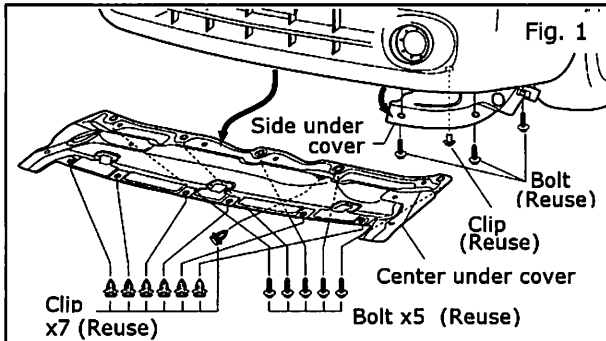

- 1) Removal of existing finisher
 - a) Pull down on side under cover to gain access to center under cover.
 - b) Remove the center under cover located under the front bumper.
- See Fig. 1.

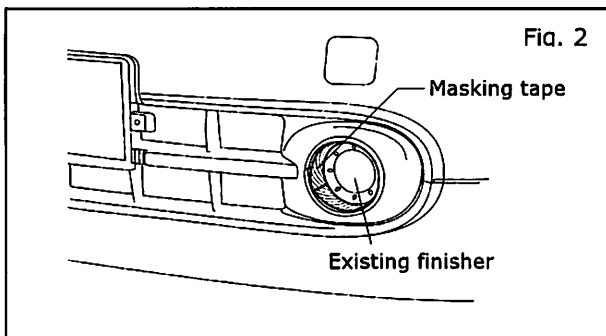

- c) Apply masking tape to the bumper around the existing finisher. (right and left)
- See Fig. 2.

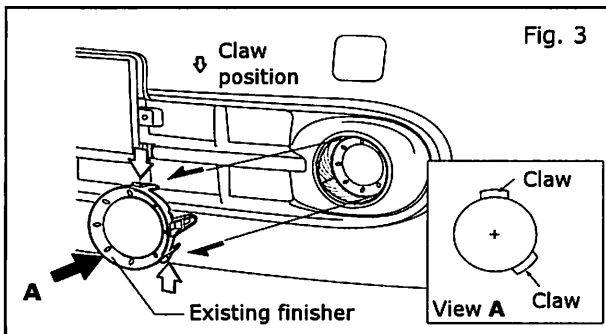

- d) Push two claws from inside the bumper to remove the existing finisher.
- Claw position: At 12 and 5 o'clock position.
See Fig. 3.

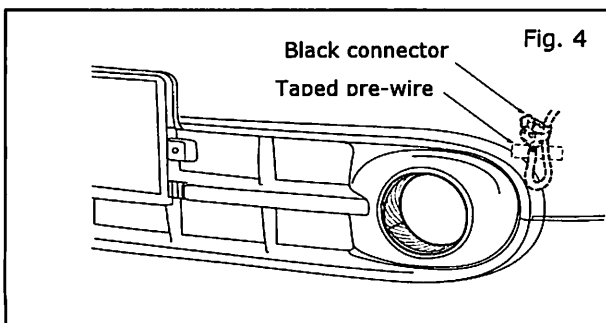

- 2) Release right and left pre-wired vehicle fog light harness.
 - a) Pull harness to break the tape.
- See Fig. 4.

INSTALLATION INSTRUCTIONS - Fog Lamp

8. INSTALLATION PROCEDURE:

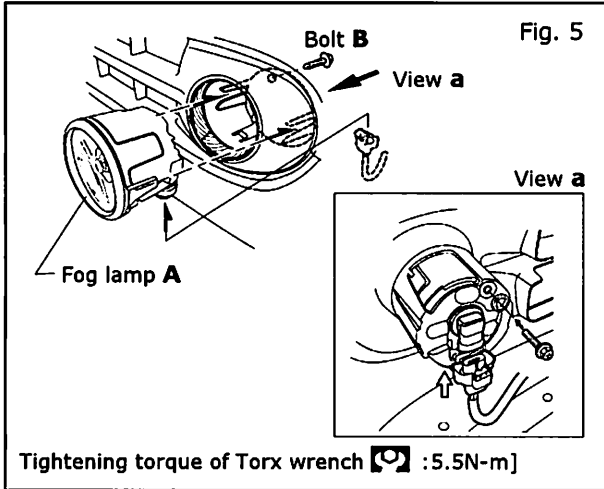

- 3) Installation of right and left fog lamps
 - a) Align 2 ribs on the side of the fog lamp with the groove located on the fog lamp installation hole. Insert the fog lamp [A] into the installation hole, until the claw on the bottom locks on fog lamp. Secure with bolt [B] from inside.
(Tightening torque of Torx wrench : 5.5 N-m)
 - b) Connect the vehicle fog lamp harness connector to the fog lamp. (right and left)
 - c) Remove the masking tape. (right and left)
See Fig. 5 (View a)

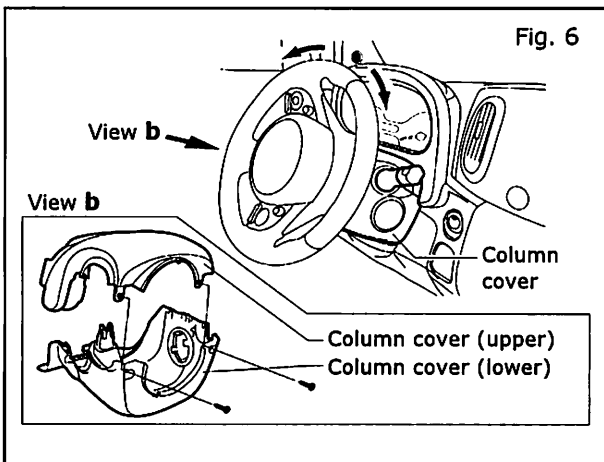

- 4) Removal of steering column cover
 - a) Remove Key ring with clamp tool.
 - b) Rotate steering wheel clockwise to access RH screw. Remove RH screw. Rotate steering wheel counter clockwise to access LH screw. Remove LH screw. Remove steering column cover upper and partially detach lower cover.
See Fig. 6 (View b)

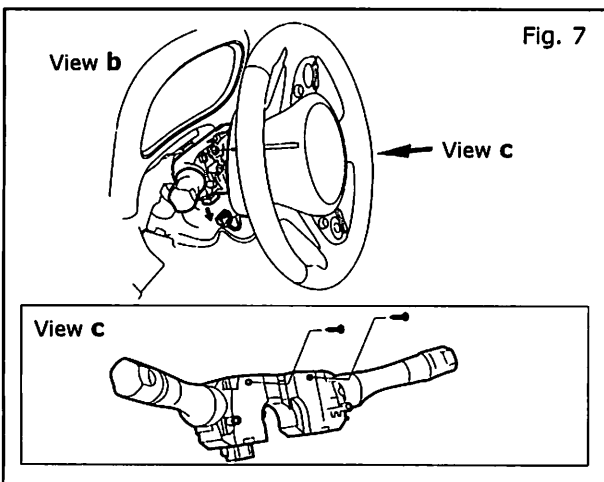

- 5) Replacement of combination switch
 - a) Remove the two screws which secure the existing combination switch.
 - b) Lift the combination switch upward and remove the connector.
 - c) Connect the connector to the combination switch [C]. Secure switch to the steering column. Using the two screws which were removed in the step 5a).

See Fig. 7 (View c)

INSTALLATION INSTRUCTIONS - Fog Lamp

9. INSTALLATION PROCEDURE:

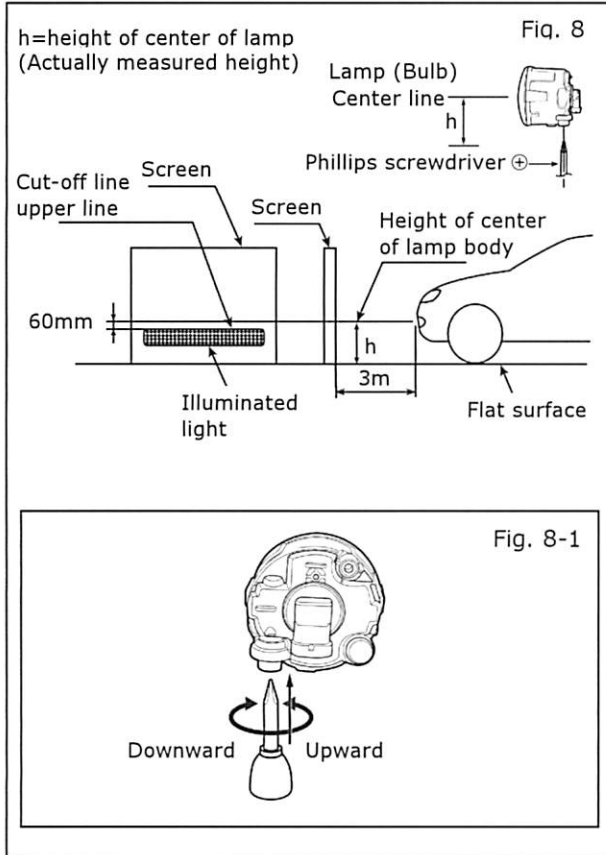

- 6) Install the steering column cover.
- 7) Connect the negative terminal of the battery.
- 8) Ensure that the fog lamp comes on. The fog lamp comes on only when the headlamp is set to the low beam. At other positions, the fog lamp will not come on.

NOTE:

- The fog lamp will not come on when the fog lamp SW only is turned ON.

- 9) Perform the photometric axis adjustment (see Fig. 8) by turning the screw located under the lamp using a Phillips screwdriver as shown in Fig. 8-1.
- 10) Ensure that the electric equipment, such as the small lamp, headlamp and turn signal lamp, functions properly.

⚠ CAUTION

- Be sure to check to see if the small lamp, headlamp and turn signal lamp function properly.

- 11) Install the center under cover and side under cover to the original positions. Using the original bolts and clips.

INSTALLATION INSTRUCTIONS - Fog Lamp

10. CHECK AFTER INSTALLATION

1) Please check that the installation has no problem.

- a) Confirm connection of connector is secure.
- b) Confirm whether wire harness is fixed.
- c) Confirm no part moving which will cause rattling noise.
- d) Confirm harness is protected from damage by sharp bracket edges.

11. FUNCTION CHECK

- 1) Re-connect battery negative terminal.
- 2) When auto light is not provided
 - With the low beam of the headlamp being illuminated, the fog lamp comes on when the fog lamp SW.ON is selected.
- 3) When auto light is provided
 - With the lighting switch set to AUTO position and the low beam of the headlamp being illuminated, the fog lamp comes on when the fog lamp SW.ON is selected.

12. REINSTALLATION OF REMOVED PARTS

- 1) All removed vehicle parts have been reinstalled.

CAUTION

- Use caution when re-installing vehicle parts to avoid damage, scratch, or breaking of mounting clips.

- 2) Clean interior of vehicle.

13. VEHICLE CHECK

- 1) Remove all tools from the vehicle.
- 2) Inspect reinstalled vehicle parts for proper panel fit.
- 3) Turn ignition to ON position.
- 4) Reset radio presets to the recorded setting.
- 5) Confirm proper radio operation.
- 6) Initialize sun roof, and power window operation.
- 7) Turn ignition to off position.

CAUTION

- During reinstallation, please use caution so as not to cause the stacking or pinching of the vehicle's harness, or damage any parts.



GENUINE PARTS

OWNERS MANUAL - Fog Lamp -

Handling instructions

Caution	Be sure to observe the caution for safety. Failure to observe the caution may cause damage or accident.
Advice	Be sure to observe the advice for your vehicle. Failure to observe the advice may cause damage to your vehicle or may not assure the designed performance.
Caution Be sure to observe the caution for safety.	<ul style="list-style-type: none">• The illuminating direction of the lamp has been adjusted in such a direction that it does not dazzle. Do not tamper the illuminating direction• Never modify the fog lamp• While the fog lamp is illuminated or immediately after it goes out, the lamp body and lens are still very hot. Never touch them• If a bulb other than the designated one is used, it may cause a vehicle fire. Be sure to use the designated bulb.• Never modify the harness, bulb, etc.
Advice Tips	<ul style="list-style-type: none">• Use the fog lamp when visibility turns bad, for example, when it is foggy, evening, rainy or snowing.• Remember that the battery may be discharged if you let the lamp remain illuminated when the engine is not running• If the bulb will not come on, contact the dealership from which you have bought the fog lamp.

How to operate the switch

- 1) When auto light is not provided
- With the low beam of the headlamp being illuminated, the fog lamp comes on when the fog lamp SW.ON is selected.

- 2) When auto light is provided
- With the low beam of the headlamp being illuminated, the fog lamp comes on when the fog lamp SW.ON is selected.
 - With the lighting switch set to AUTO position and the low beam of the headlamp being illuminated, the fog lamp comes on when the fog lamp SW.ON is selected.

