



GENUINE PARTS

INSTALLATION INSTRUCTIONS

DESCRIPTION:	Vehicle Tracking and Recovery System
APPLICATION:	Altima (2013)
PART NUMBER:	999Q8 VY001

KIT CONTENTS:

Item	Qty.	Part Description	Service Part Number
A	1	VTRS Control Module	999Q8 VY002
B	1	Wire Harness	999Q8 VY003
C	1	I/I Download Instructions	999V2 AW000
D	1	Owners Manual	
E	1	Activation Card (included in owners manual)	
F	8	6" Cable Ties	
G	2	12" Cable Ties	
H	1	Foam Pad (on module)	
I	10	Foam Tape	
J	3	Posi-Taps	999M1 VT000
K	1	Mirror Hanger (Nissan VTRS information)	
L	1	Alcohol wipe	
M	1	Accessory Service Connector (NOT INCLUDED IN KIT)	999Q9 AY000

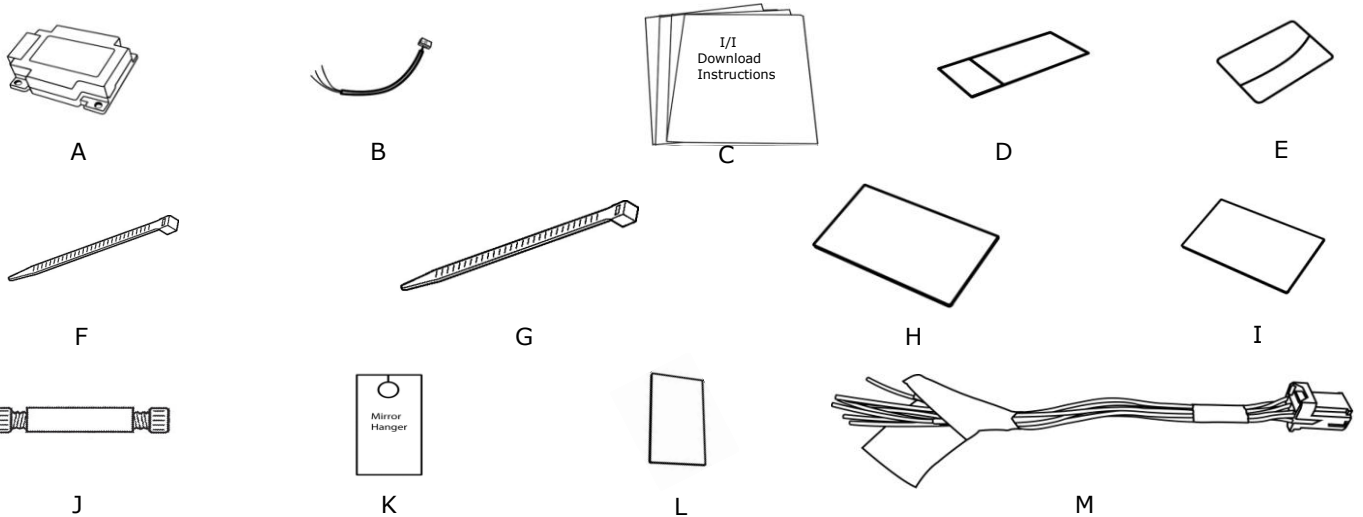

TOOLS REQUIRED:

- Ratchet
- 10mm socket
- #2 Phillips screwdriver
- Plastic pry bar
- Wire cutter

PRE-INSTALLATION WARNINGS, CAUTIONS, CRITICAL STEPS, and NOTES:

- Dealer Installation Recommended. Instructions may refer to service manual.
- This part is to be installed at a surface temperature of 65-100°F.
- Posi-Tap instructions must be followed exactly as described in this instruction.
- Accessory Service Connector (999Q9 AY000) is **NOT INCLUDED** in the kit.

INSTALLATION OVERVIEW:

System Block Diagram

Fig.1



Vehicle outline with installation overview

Fig.2

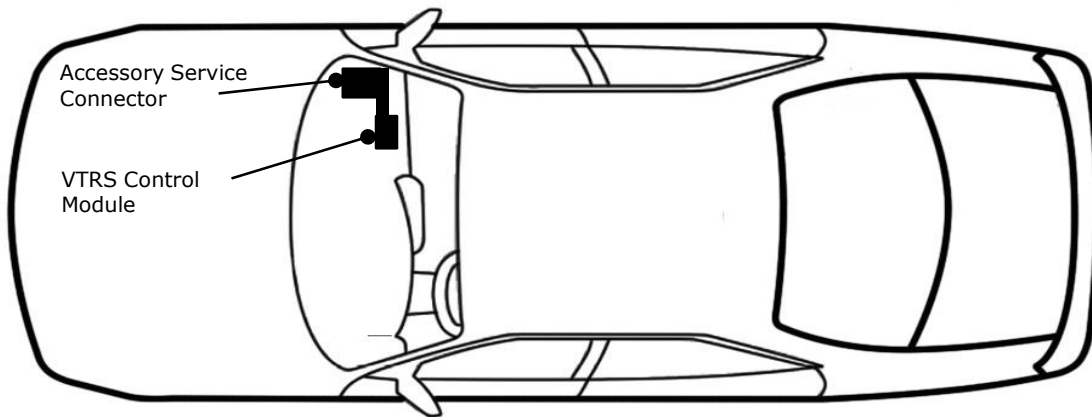

INSTALLATION PROCEDURE:

- 1) Apply parking brake
- 2) Confirm the vehicle is no longer in the default shipping state (Extended Storage Switch Pulled Up and BCM in Transit Mode). Failure to confirm the vehicle has been removed from this state will result in the loss of normal vehicle operation. The confirmation requires two checks:
 - 2a) Locate the Extended Storage Switch in the cabin fuse block. Once located, check that it is in the "Customer" position. See below for reference.
 - 2b) Turn the ignition switch from "OFF" to "ON" position. If turn indicators illuminate for approx. 1 minute, the vehicle is in shipping mode. To exit shipping mode, return the ignition switch to "OFF" position. Simultaneously push the wiper and turn signal stalks downward and hold for 2 seconds.

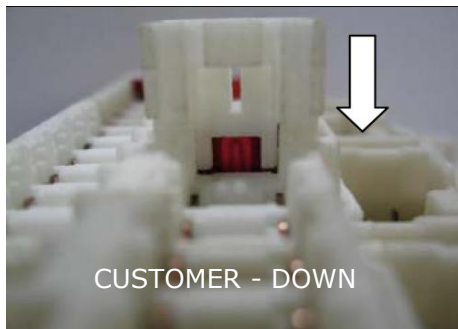
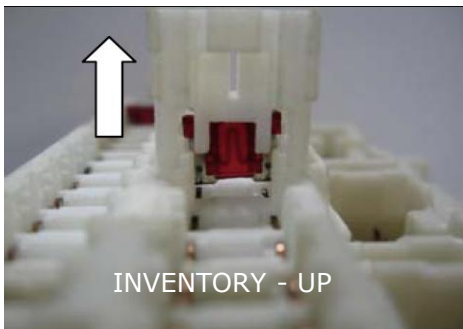
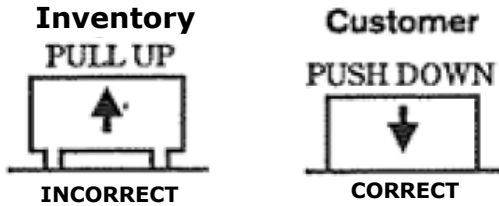

Note: Typical vehicle condition shown above. Switch is easily identifiable by the permanent, push-pull fuse holder. Actual position on the fuse block may vary, vehicle to vehicle.

- 3) Turn ignition switch to "ON" position
- 4) Record the customer radio presets and other presets as required

Preset	1	2	3	4	5	6	7	

- 5) Put the shift lever in "P" position
- 6) Turn the ignition switch to "OFF" position

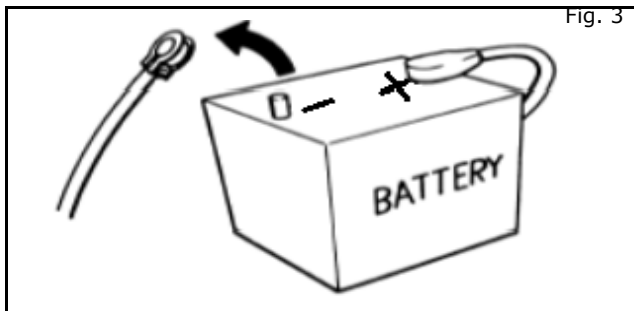

- 7) Disconnect the negative battery terminal

INSTALLATION PROCEDURE:

CAUTION

- Take care not to scratch or damage any component during the removal or re-installation process.
- Trim pieces found to have witness marks or broken clips are not to be reinstalled.

8) Remove the following vehicle parts in the sequence shown below. Store these re-usable parts in a safe and protected manner.

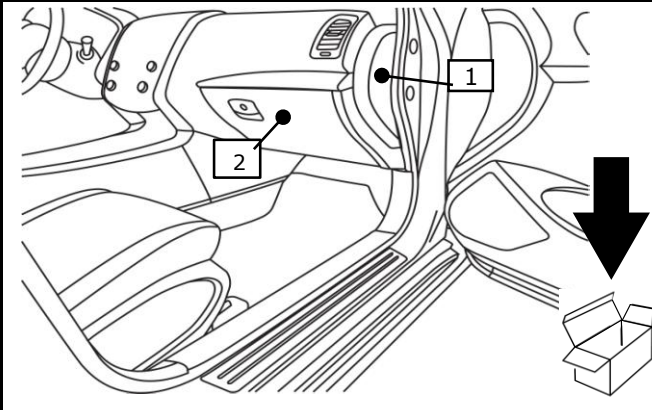

Fig.4

- 1) Passenger side mask
- 2) Glove box

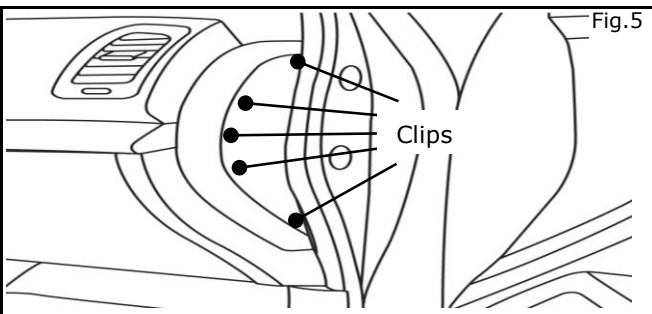

Fig.5

9) Remove passenger side mask

10) Remove glove box

- a) Open the glove box lid
- b) Remove (8) phillips screws
- c) Pull glove box assembly
- d) Disconnect trunk release connector
- e) Disconnect illumination lamp harness clip and harness connector

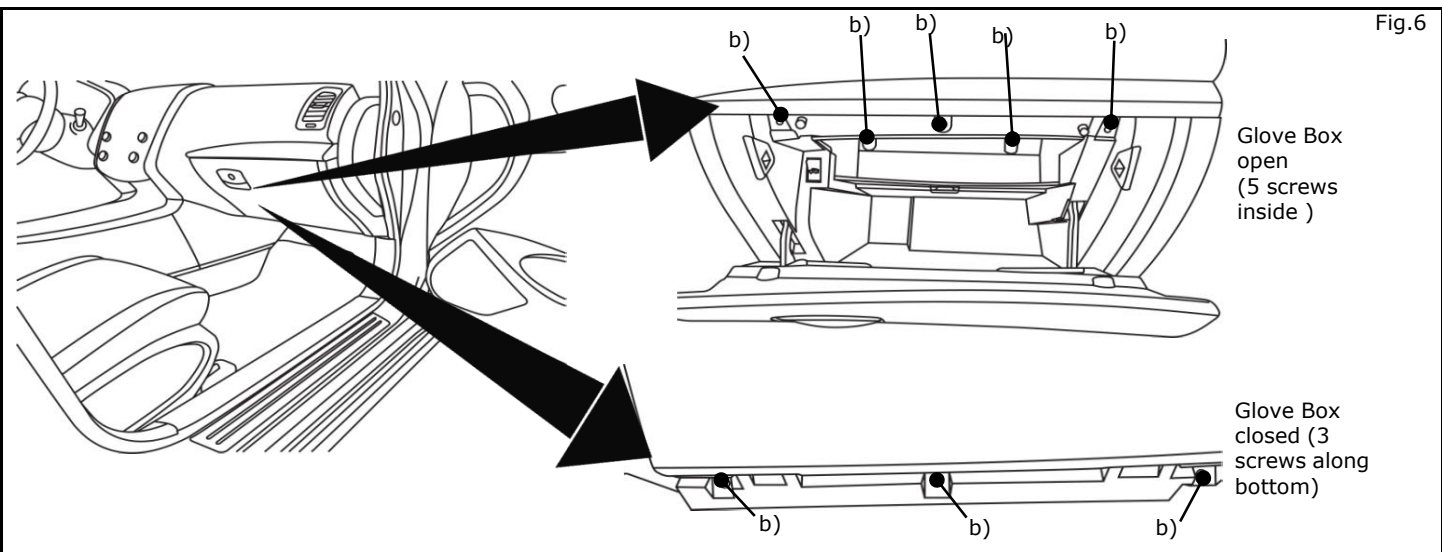

Fig.6

Glove Box open
(5 screws inside)

Glove Box closed (3 screws along bottom)

INSTALLATION PROCEDURE:

⚠ CAUTION

- Color(s) given in illustration(s) are for reference only. Use location(s) where color deviates.
- Do not pinch the harness between trim when re-installing the Glove Box.
- A previously installed accessory may be present. If so, carefully remove the accessory connector from the accessory connector plug before posi-tapping. It is recommended that all posi-tapping be completed before reattaching the accessory connector harness to the plug.
- Be sure to grab the connector and not the harness when separating the plug from the foam tape.
- If a vehicle wire is being used by another accessory and a posi-Tap is present, tap the accessory wire not the vehicle wire.

11) Connect the posi-tap.

- a) Tap the Vehicle Tracking and Recovery System Red wire to the Vehicle accessory service connector Red B+ wire
(Accessory Service Connector NOT INCLUDED IN KIT).

Pin #	Function	Wire Size	Color	Comment
1	BAT		R	
2				No wire; Reserved for future use
3	ACC		O	
4				No wire; Reserved for future use
5	BATSVR		P	
6	DOOR		G	
7	CROSS2		L	
8	CROSS1		SB	
9				No wire; Reserved for future use
10	RM LMP		Y	
11				No wire; Reserved for future use
12	GND		B	

Fig.7

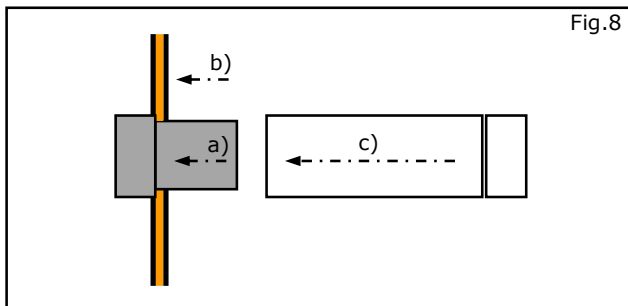
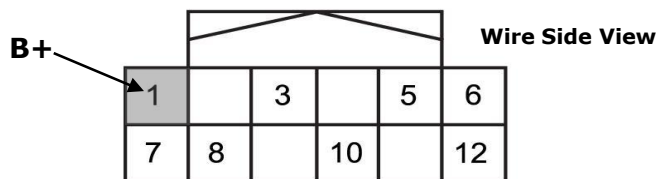
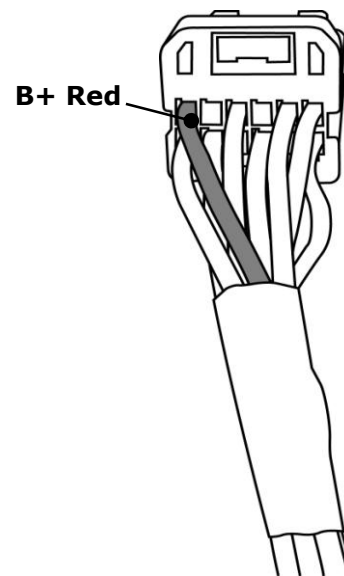

12) Tap vehicle wire.

- Remove cap (slot side) from the tap body
- Slide cap around vehicle wire.
- Tighten the tap **TIGHT** with finger pressure.

NOTE:

Do not re-use the tap for subsequent re-installation. Figures are not to scale.

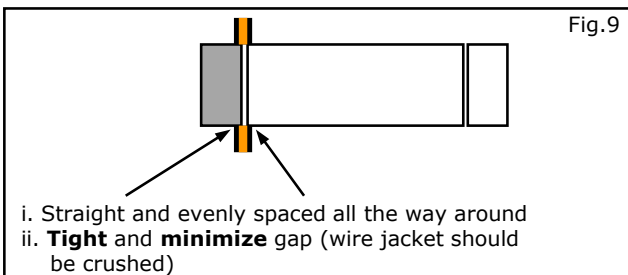

13) Inspect the tap to ensure correct installation.

NOTE:

Avoid putting pressure on the vehicle wire and tap for the remainder of the installation.

INSTALLATION PROCEDURE:

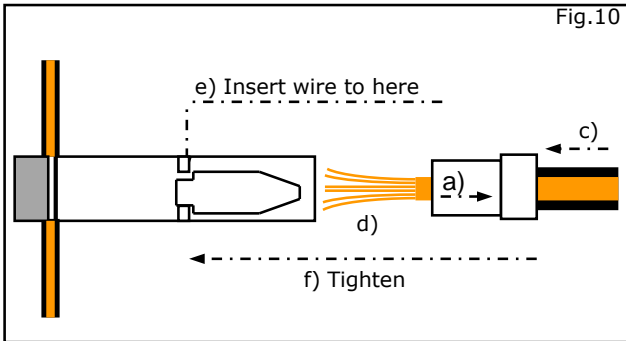

- 14) Tap B+ wire.
 - a) Remove tap (non-pierce) side from tap.
 - b) Remove the protective stub from the red B+ wire.
 - c) Insert wire through the non-pierce side opening.
 - d) Spread the individual strands into fan shape.
 - e) Insert wire into the tap body and ensure that it is all the way in.
 - f) Tighten the tap **TIGHT** with finger pressure.

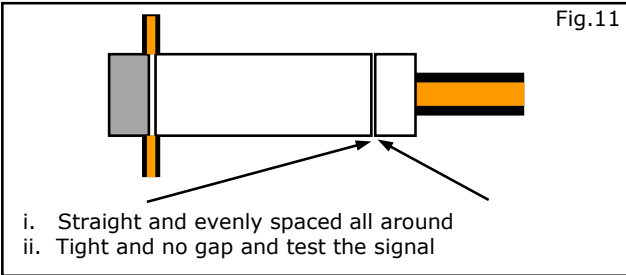

- 15) Confirm the tapped B+ wire.
 - a) Inspect the tap to ensure correct installation.
 - b) Test the signal to ensure that it is working properly.

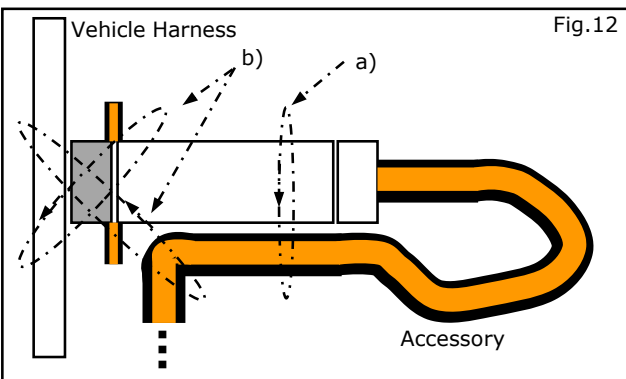

- 16) Secure the tap.
 - a) Secure the tapped wire on the non-pierce side to the body of the tap with electrical tape (≥ 2 revolutions).
 - b) Secure the body to harness where vehicle wire is being tapped with electrical tape (≥ 2 revolutions).

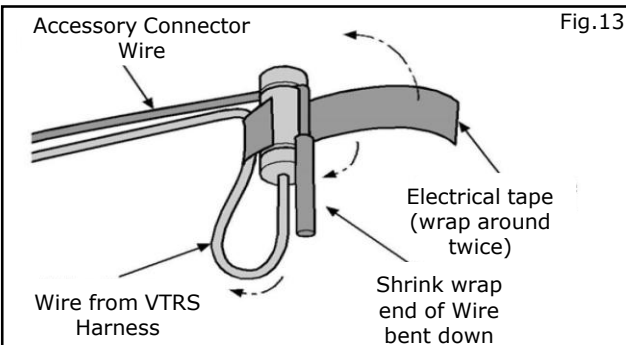

- 17) **Follow this finishing procedure on all posi-taps.** Leave a short length of wire extended past the posi-tap and bend down as shown. Use electrical tape to secure the extra wire against the posi-tap with at least two revolutions.

Note: Make sure that the end of the wire is completely covered by the tape.

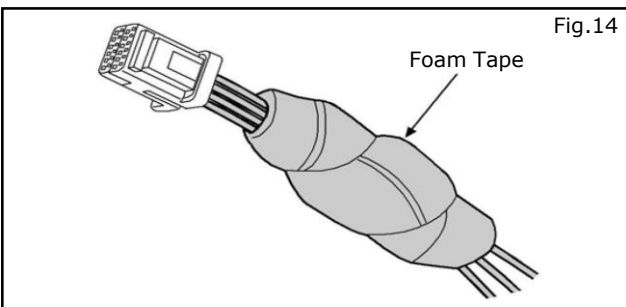

- 18) Wrap the posi-taps with foam tape to prevent rattle.

INSTALLATION PROCEDURE:

- 19) Tap the Vehicle Tracking and Recovery System Brown wire to the Vehicle accessory service connector Orange ACC wire. See steps 12-16 for wire tap installation instructions.
- 20) Tap the Vehicle Tracking and Recovery System Black wire to the Vehicle accessory service connector Black Ground wire. See steps 12-16 for wire tap installation instructions.

Pin #	Function	Wire Size	Color	Comment
1	BAT		R	
2				No wire; Reserved for future use
3	ACC		O	
4				No wire; Reserved for future use
5	BATSVR		P	
6	DOOR		G	
7	CROSS2		L	
8	CROSS1		SB	
9				No wire; Reserved for future use
10	RM LMP		Y	
11				No wire; Reserved for future use
12	GND		B	

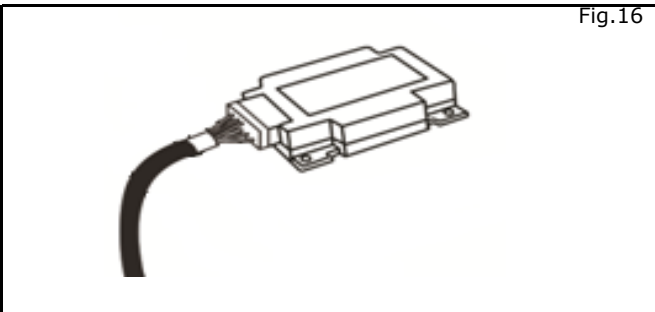
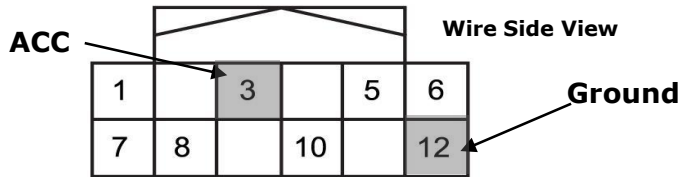
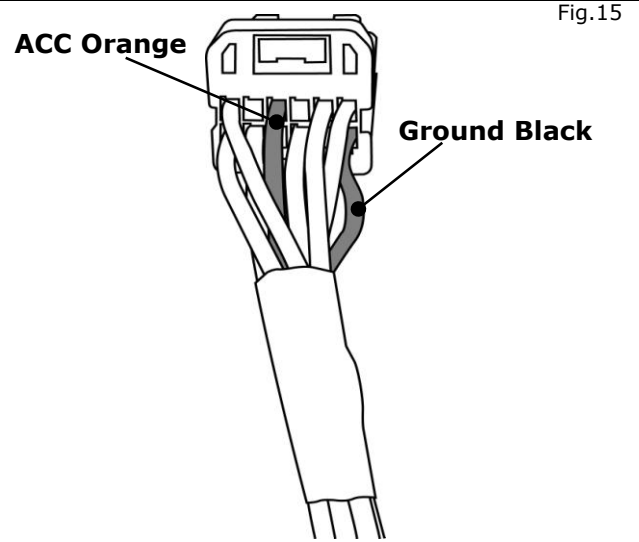

- 21) Connect the harness to the VTRS control module.

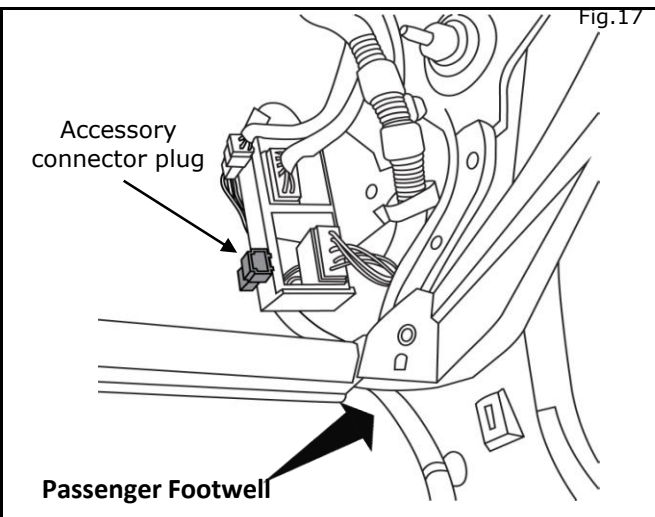

- 22) Locate the vehicle's accessory connector plug located behind the lower right portion of the glove box inside the passenger foot well.
- 23) Plug the Accessory Service Connector into the vehicle accessory connector plug on the passenger side.

ACCESSORY CHECK:

- Connect all vehicle harness connections (without re-assemble).
- Connect the battery negative terminal and tighten the nut to 5.4 N-m (47.8 lb-in).
- Check all Installation.
- Verify the Control Module Diagnostic L.E.D.'s are blinking Green.
- Verify proper Diagnostic L.E.D. blinking pattern (without engine start).
 - Turn ignition to "ON" position, the L.E.D. will blink once every two seconds.
- If the Control Module fails the L.E.D. diagnostics test, reject the part per rejection protocol.
 - Repeat the L.E.D. diagnostic test with a new Control Module.
- Disconnect the negative battery terminal.

INSTALLATION PROCEDURE:

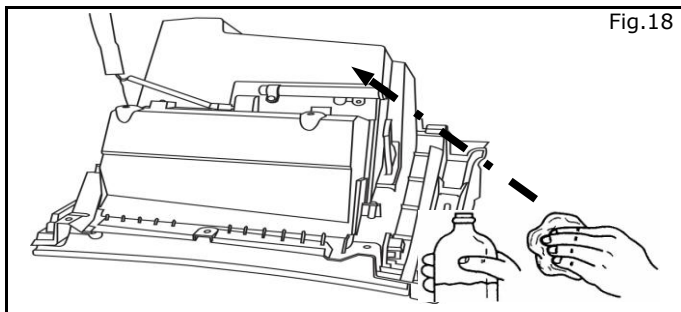

- 24) Prepare the module
- a) Clean glove box installation surface with $\geq 90\%$ alcohol/water solution

- b) Peel tape liner from foam pad on Module
- c) Adhere module to top of glove box
- d) Attach foam tape
- e) Attach cable ties

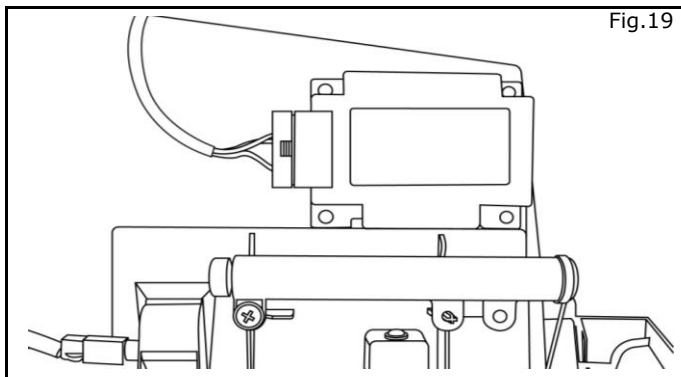

INSTALLATION PROCEDURE:

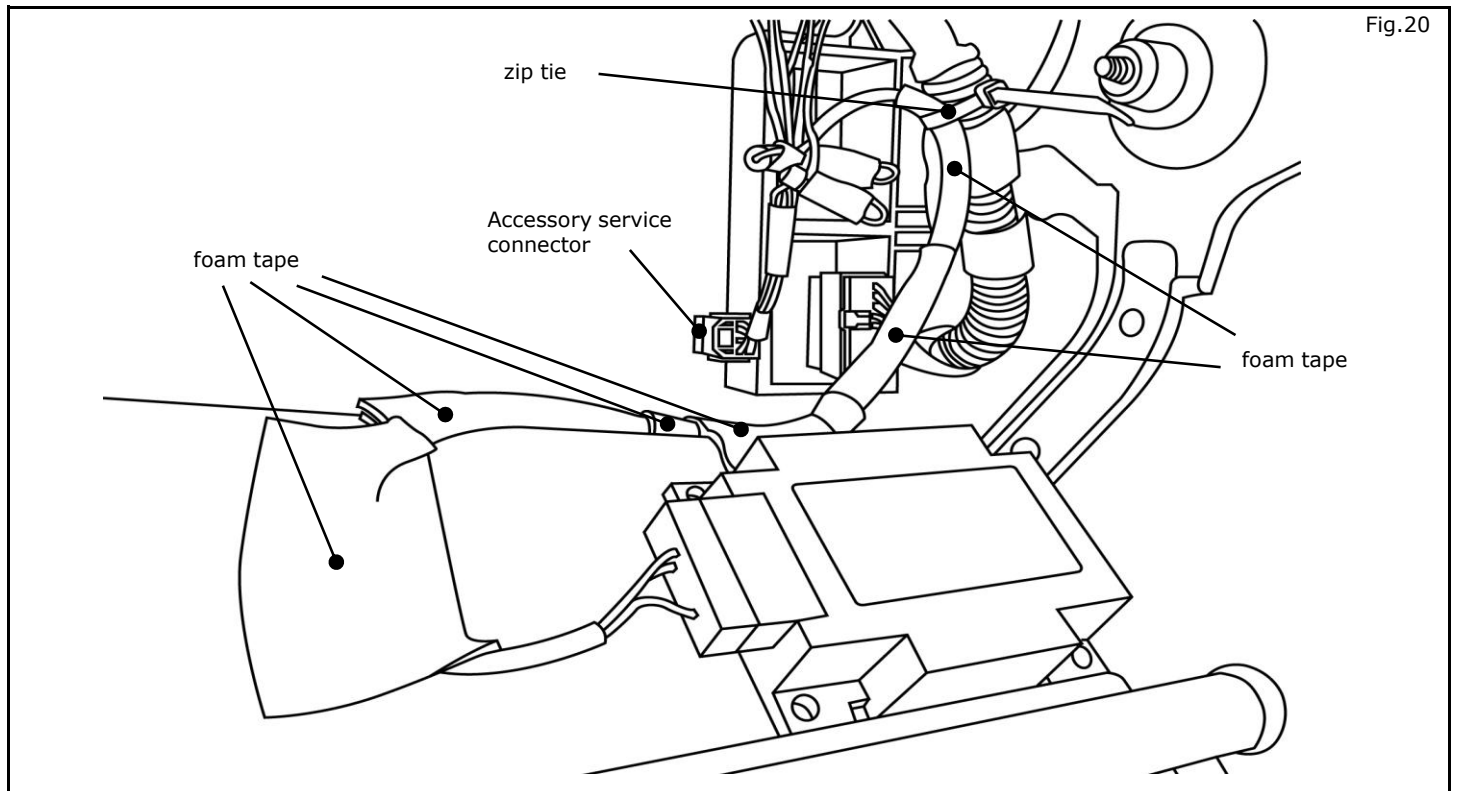

25) Re-install all removed vehicle parts. Refer to the vehicle service manual for more details.

FINAL INSPECTION:

CAUTION

Use caution when re-installing interior components to avoid damage, scratches, or breaking of mounting clips. Refer to the vehicle service manual for more information.

- Verify re-installed trim parts for proper flush fit (no gap, no waviness, etc.).
- Verify all clips are fully engaged and locked.
- Verify re-installed trim parts are free from cracks, scratches or stress marks.
- Verify vehicle headliner, seat, steering wheel, center console, floor carpets, etc. are not soiled.
- Verify interior and exterior is not damaged.
- Connect the battery negative terminal and tighten the nut to 5.4 N-m (47.8 lb-in).

FINAL INSPECTION:

- Turn ignition switch to "ON" and confirm proper operation of Vehicle Systems.
 - If equipped, verify all window and sunroof one touch operation and perform the reset procedure if necessary. Refer to the vehicle service manual for more details.
 - Confirm proper audio function (AM, FM, SAT, CD and AUX).
- Re-program radio presets and other vehicle settings to the recorded settings.
- Turn ignition switch to "OFF". Wait 10 seconds, then switch to "ON".
- Start engine and verify that there are no new Diagnostic Trouble Codes and the Meter is functional.
- Attach additional Label (ESN number) in VTRS Owners Manual Page # 1.
- Place the VTRS Owner Manual, Quick Reference Guide, and/or other Manual in the glove box.
- For activation information, please refer to the VTRS Owner's Manual.
- Secure mirror hanger to rear view mirror.