



# GENUINE PARTS

## INSTALLATION INSTRUCTIONS

<b>DESCRIPTION:</b>	DUAL DVD HEADRESTRAINT MONITOR
<b>APPLICATION:</b>	Armada
<b>PART NUMBER:</b>	Dual DVD HeadrestRAINT Monitor Leather, (G;1) Charcoal - 999U8 2Z000 Dual DVD HeadrestRAINT Monitor Leather, (Y;1) Almond - 999U8 2Z001 Dual DVD HeadrestRAINT Monitor Leather, (G;1) Charcoal - 999U8 2Z002 (Platinum Grade) Dual DVD HeadrestRAINT Monitor Cloth, (G;1) Charcoal - 999U8 2Z005 Dual DVD HeadrestRAINT Monitor Cloth, (Y;1) Almond - 999U8 2Z006

KIT CONTENTS:			Service Part Number
Item	Qty.	Part Description	
A	1	DVD HeadrestRAINT Monitor (DR)	See Service Part Number list at end of manual
B	1	DVD HeadrestRAINT Monitor (AS)	
C	1	Customer Prepack	
	2	• Wireless Headphones w/Batteries	
	1	• Remote Control w/Batteries	
	1	• Owner's Manual	
	3	• Quick Reference Guide	
D	1	Installation Prepack	
	16	• Cable Tie	
	4	• Security Clamp	
	4	• Foam Tape Strip	
	1	• 16-Pin Jumper Harness, Driver	
E	1	Controller Assembly Prepack	
	1	• Control Module and Bracket Assembly	
	3	• M5 Flange Bolts	

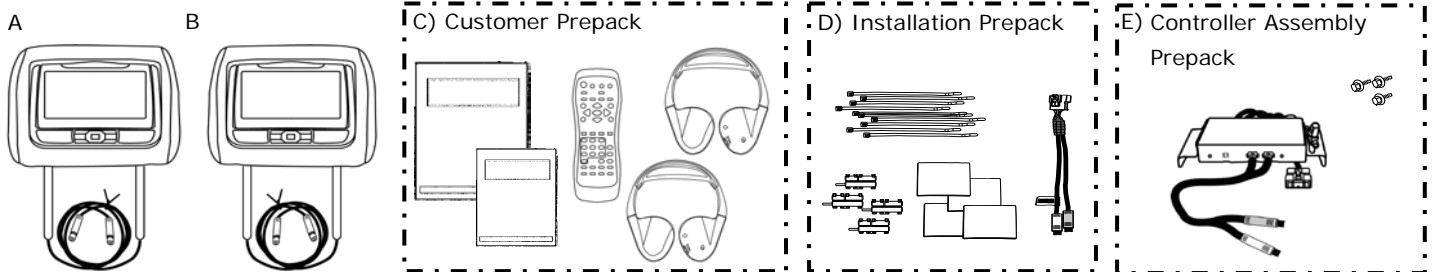

### TOOLS REQUIRED:

- Socket, 8mm, 10mm and 1/4" Phillips Tip
- Torque Wrench
- Ratchet, 1/4" Drive
- Screwdriver, Phillips
- Plastic Removal Tool
- Diagonal Cutters

Please call Invision Tech-line help at 866-869-7888 for any installation, repair or warranty assistance.

### PRE-INSTALLATION WARNINGS, CAUTIONS, CRITICAL STEPS, and NOTES:

**NOTE:** This is a common installation kit so all parts may not be used.

## ⚠ CAUTION

- **Caution Dealer installation ONLY.**
- **Caution** Cut the excess cable tie(s) as flush with the head as possible. Face head of cable tie away from sheet metal and other objects.
- **Caution** Use caution when removing/re-installing interior components to avoid damage, scratches, or breaking of mounting clips.

## ⚠ CAUTION

**Critical Steps:** The following steps are critical and must be performed **EXACTLY** as specified to ensure proper installation.

- Critical Step 1. All Cable and Harness routing instructions need to be followed as described to avoid interferences or system failure.
- Critical Step 2. Ensure headrests are set to the highest position when routing the cables to connect to the control module assembly.

### INSTALLATION OVERVIEW:

System Block Diagram

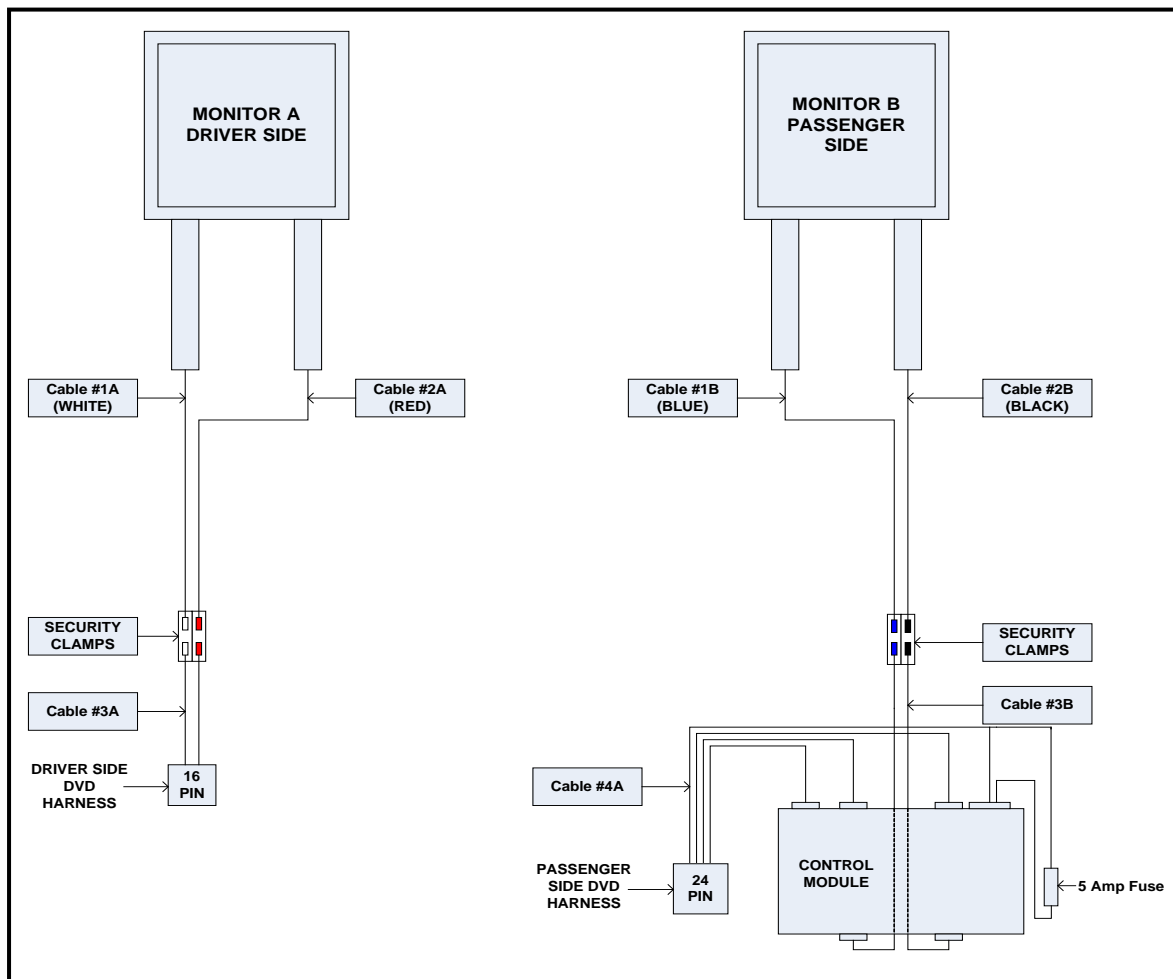

**VEHICLE PREPARATION PROCEDURE:**

- 1) Apply parking brake.
- 2) Confirm the vehicle is no longer in the default shipping state (Extended Storage Switch Pulled Up and BCM in Transit Mode). Failure to confirm the vehicle has been removed from this state will result in the loss of normal vehicle operation. The confirmation requires two checks:

2a) Locate the Extended Storage Switch in the cabin fuse block. Once located, check that it is in the "Customer" position. See below for reference.

2b) Turn the ignition switch from "OFF" to "ON" position. If turn indicators illuminate for approx. 1 minute, the vehicle is in shipping mode. To exit shipping mode, return the ignition switch to "OFF" position. Simultaneously push the wiper and turn signal stalks downward and hold for 2 seconds.

Inventory Condition

Customer

PULL UP

PUSH DOWN

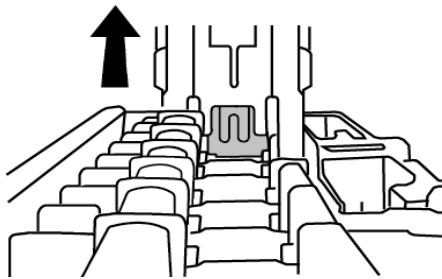
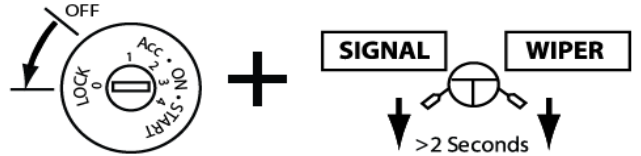
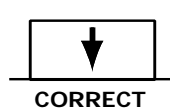
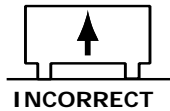

INVENTORY - UP

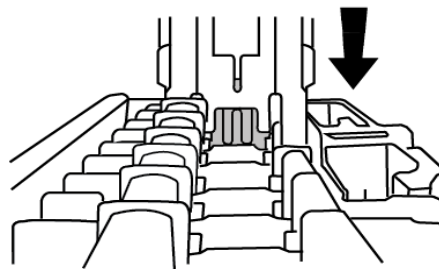

CUSTOMER - DOWN

**NOTE:**

Typical vehicle condition shown above. Switch is easily identifiable by the permanent, push-pull fuse holder. Actual position on the fuse block may vary, vehicle to vehicle.

- 3) Turn ignition switch to "ON" position.
- 4) Record the customer radio presets and other presets as required.

Preset	1	1	2	3	4	5	6	7
A								
B								
C								

- 5) Put shift lever in "P" position for A/T and CVT or "1st" for M/T.
- 6) Turn ignition switch to "OFF" position.

**NOTE: Use caution when removing interior components to avoid damage, scratches, or breaking of mounting clips. Refer to the vehicle specific service manual for more information**

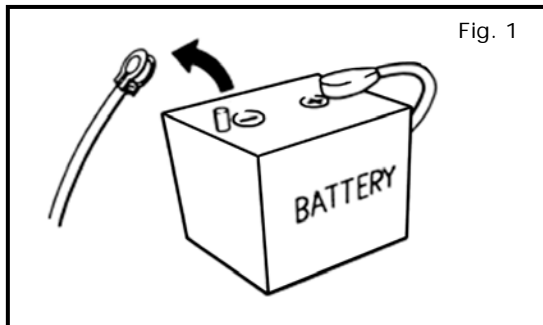

- 7) Open the engine hood.
- 8) Disconnect negative battery terminal to prevent short circuits during installation procedure. Figure 1
  - a) Set power seats to Full Up and Forward positions.
  - b) Disconnect negative battery terminal.

## INSTALLATION PROCEDURE: DRIVER SIDE

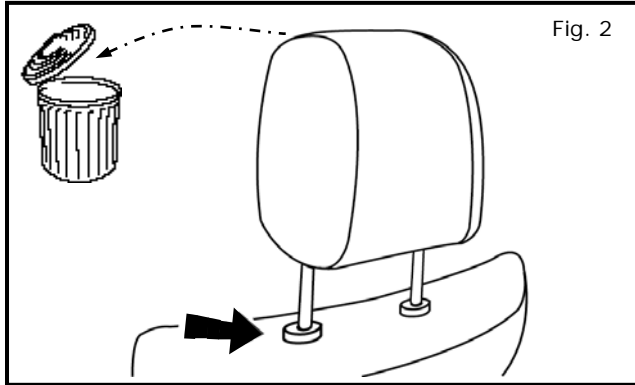

### 9) Driver Side DVD Headrest Installation

- 9.1) Remove and dispose of driver headrest by pressing release button on seat post guide, and pulling up on headrest. Figure 2

**NOTE: Seat position may need to be adjusted for the removal of the factory headrest and installation of the DVD headrest.**

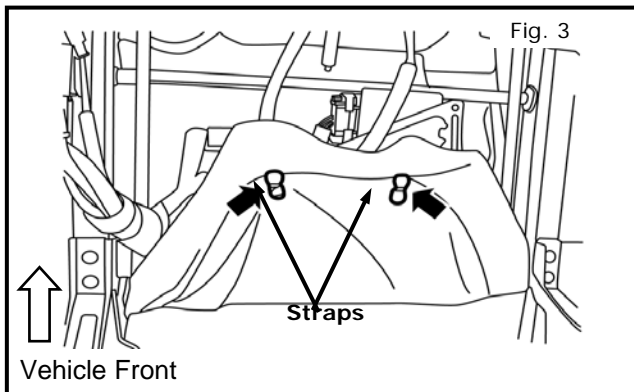

- 9.2) Disconnect two straps holding seat back apron to underside of driver seat. Figure 3

**NOTE: Use caution when inserting the DVD headrest posts to prevent damage/scratching of seat post guides and seating surface.**

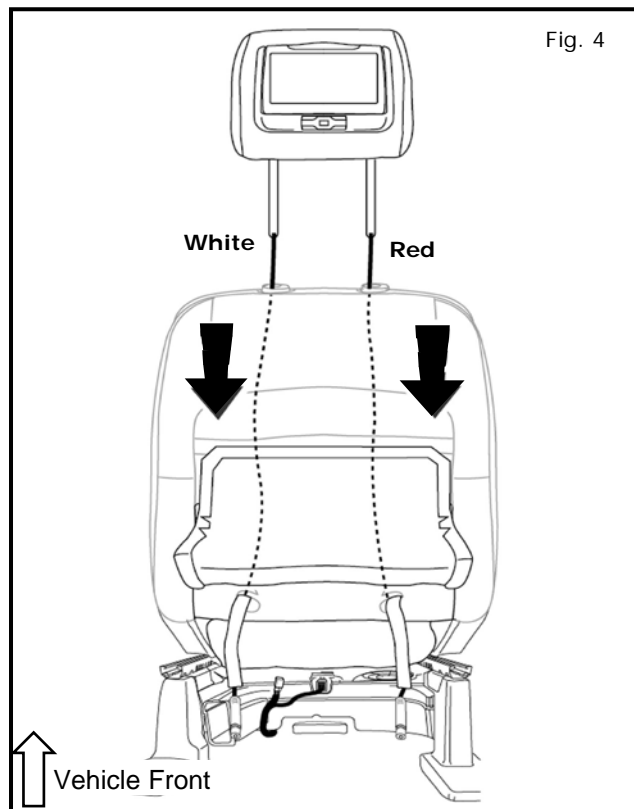

- 9.3) Insert driver DVD headrest cables (white/ red) into seat post guide holes of driver seat as shown. Continue routing cables down through seat back and out of seat bottom. Figure 4

**NOTE: When installing driver DVD headrest cables, it is important that DVD screen is positioned correctly. DVD screen must face rearward.**

## INSTALLATION PROCEDURE: DRIVER SIDE (continued)

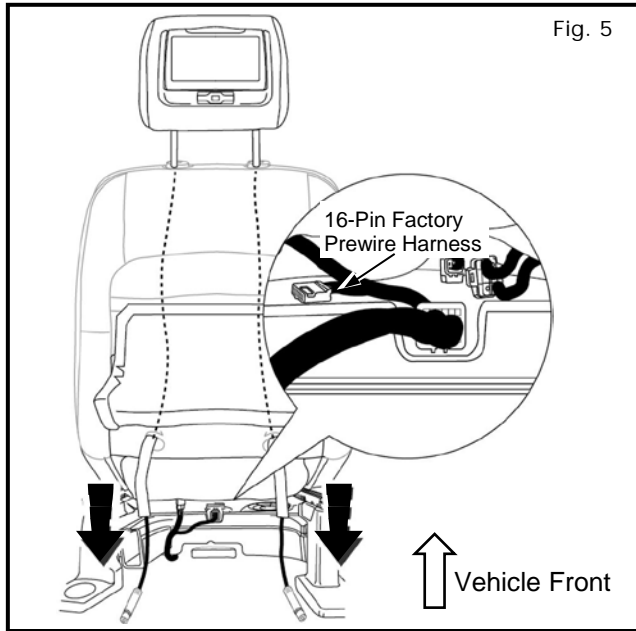

9.4) Insert driver DVD headrest posts into seat post guides. Lock DVD headrest into its highest position (Bottom-Most Notch). Figure 5

9.5) Pull on two headrest cables from seat bottom to remove all slack. Figure 5

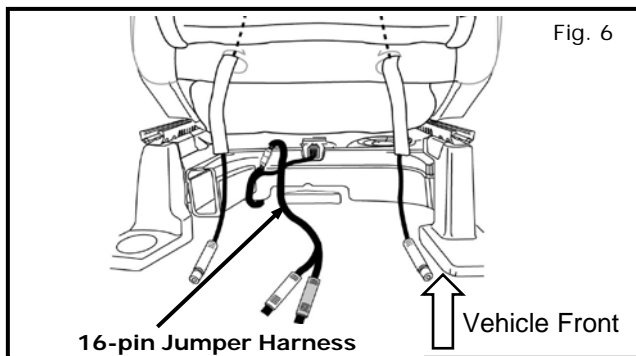

9.6) Locate factory prewire harness under driver seat (see Figure 5) and connect 16-pin jumper harness. Figure 6

**NOTE: Perform cable connection steps, 9.7 through 9.10, as noted to install DVD Headrest correctly for proper operation.**

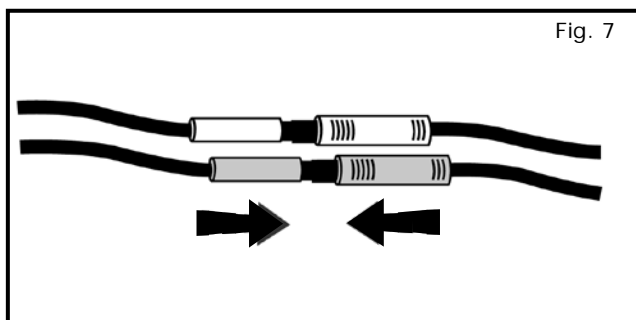

9.7) Connect red and white barrel connectors to matching red and white barrel connectors of 16-pin jumper harness. Figure 7

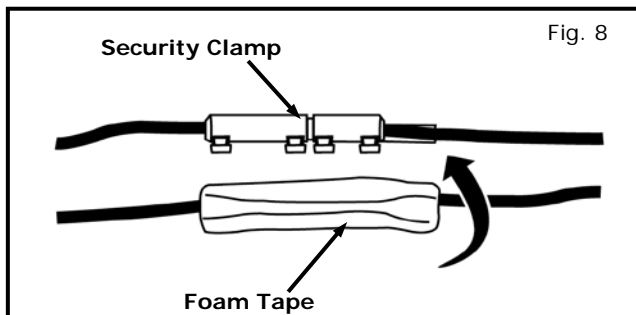

9.8) Secure barrel connectors using two security clamps. Place red barrel connectors into one security clamp and lock closed. Place white barrel connectors into second security clamp and lock closed. Figure 8

9.9) Apply one piece of foam tape over each security clamp. Figure 8

**INSTALLATION PROCEDURE: DRIVER SIDE (continued)**

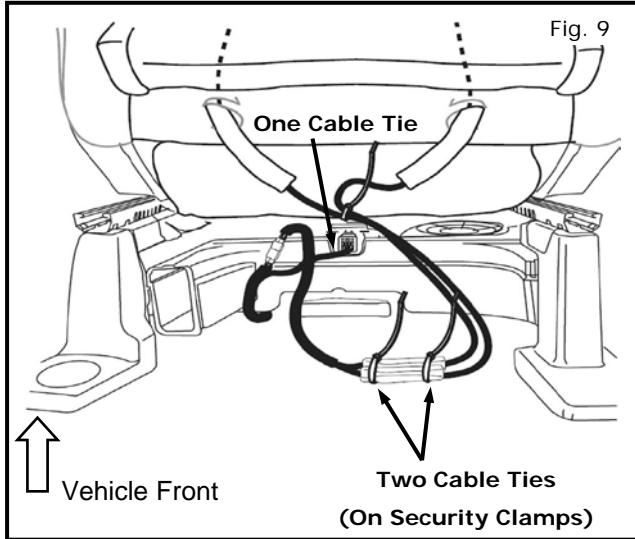

9.10) Use three cable ties to secure headrest cables.

a) Group headrest cables to center of seat and secure using one cable tie. Figure 9

b) Use two cable ties to secure foam tape wrapped around barrel connections. Figure 9

**NOTE: Place cable ties over the foam tape about a half- inch (1/2") from ends.**

9.11) Use five cable ties to secure headrest cables to the factory harness. Figure 10A

**NOTE: Follow the factory harness to ensure there is enough slack for seat movement.**

**NOTE: Accessory harness needs to be inboard of the factory harness as shown in Figure 10A.**

**NOTE: Leave at least a one inch space between cable ties and 16-Pin connector to ensure no stress is placed on connectors.**

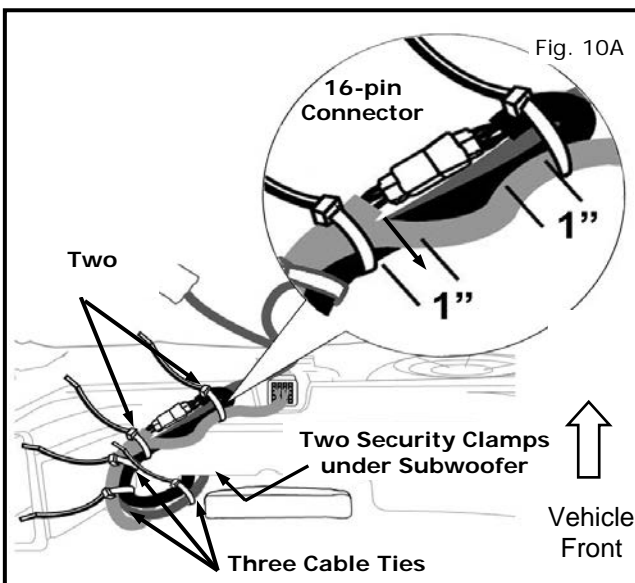

9.12A) Insert two security clamps under the factory amplifier. Figure 10A

**NOTE: Before tightening cable ties, reconnect battery and exercise seat to ensure wiring does not interfere with seat movement. Disconnect battery when complete.**

**NOTE: Following instructions for Driver seats without Factory Subwoofer.**

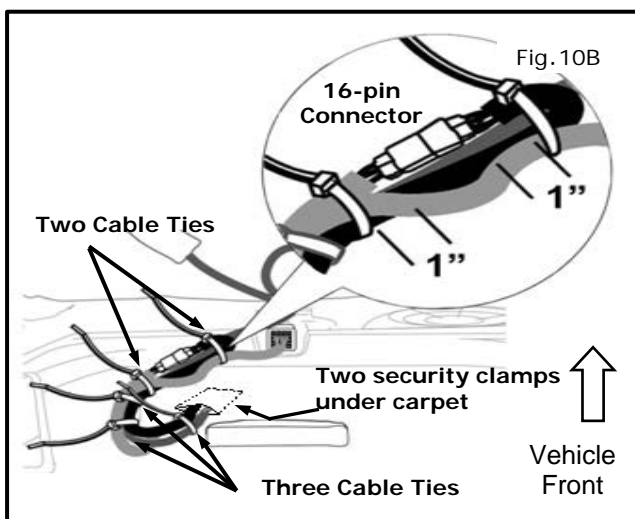

9.12B) Insert two security clamps under the carpet following the factory harness. The lowest cable tie should be at the carpet opening concealing the security clamps. Figure 10B

9.13) Cut all excess wire ties using Diagonal cutters.

9.14) Reattach two seat back apron straps.

9.15) Continue to Passenger Side DVD Headrest Installation step 10.

## INSTALLATION PROCEDURE: PASSENGER SIDE

### 10) Passenger Side DVD Headrest Installation

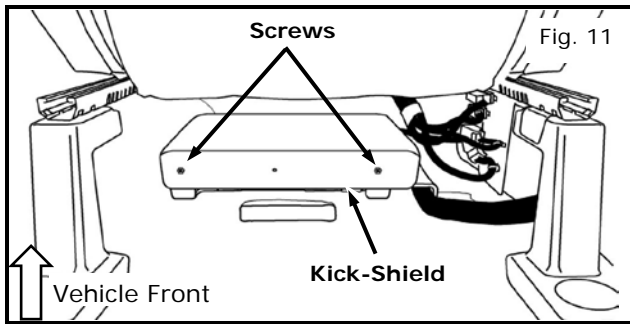

- 10.1) Using a Phillips screwdriver, remove two screws and kick-shield under passenger seat. Figure 11

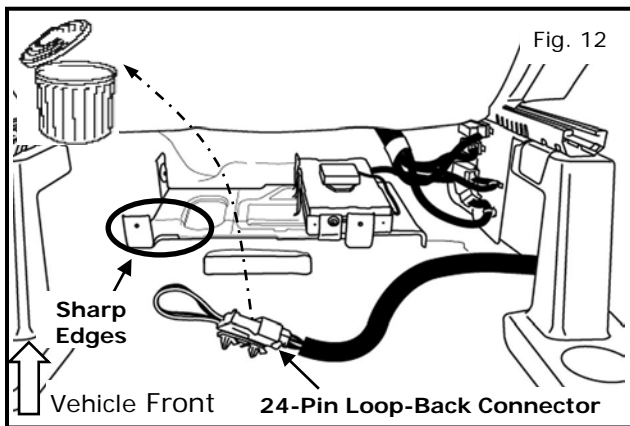

- 10.2) Disconnect the factory prewire harness from the bracket below the front Passenger seat.
- 10.3) Using a plastic pry tool, disconnect and dispose of 24-pin loop-back blank connector under passenger front seat. Figure 12.

**CAUTION: Use hand protection when working on the accessory mounting bracket to avoid injury.**

**NOTE: For vehicles without factory Bluetooth Module option proceed to Step 10.6**

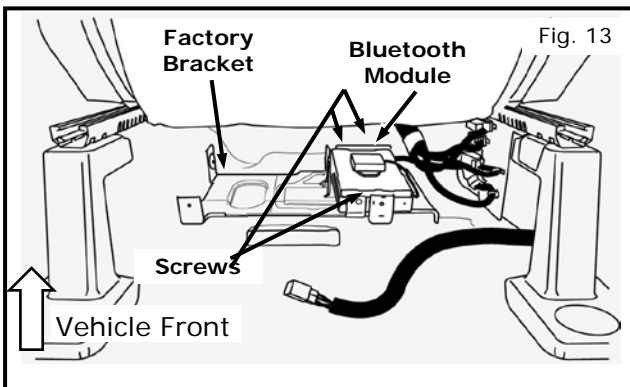

- 10.4) Using a Phillips screwdriver, remove three screws used to attach factory Bluetooth Module to factory accessory mounting bracket. Figure 13

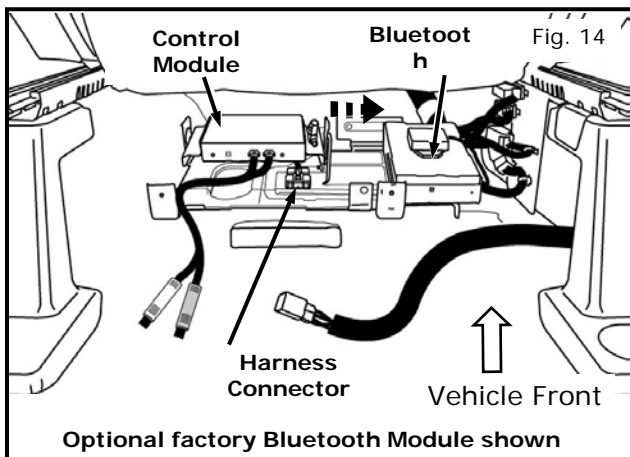

- 10.5) Without disconnecting Bluetooth Module connectors, move Bluetooth Module towards outboard side of vehicle. This will allow for room to install Control Module Assembly in Step 10.7. Figure 14
- 10.6) With Control Module Assembly placed in position on factory bracket, attach 24-pin jumper harness by pressing two pins on bottom of harness connector into two holes located under control module on the factory accessory bracket. Figure 14

**INSTALLATION PROCEDURE: PASSENGER SIDE (continued)**

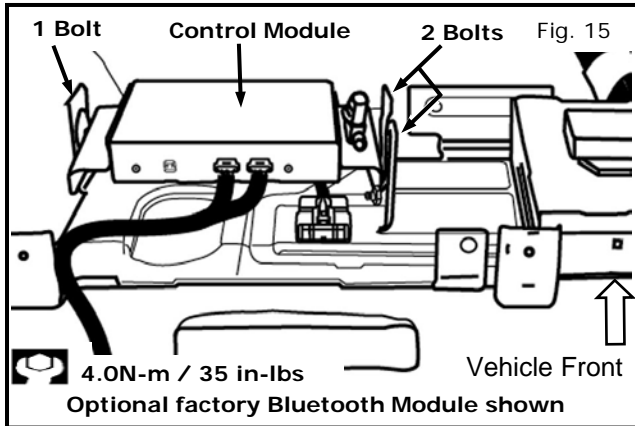

10.7) Using a ratchet and 8mm socket, install three M5 bolts to attach Control Module Assembly to factory accessory mounting bracket. Figure 15

- a) 8mm socket for M5 bolts (4.0 N-m/ 35 in-lbs). Figure 15

**NOTE: For vehicles without factory Bluetooth Module option proceed to Step 10.9**

10.8) Reinstall Factory Bluetooth Module into factory mounting bracket using three screws removed in Step 10.3

- a) 1/4" Phillips Tip Socket for Phillips Screws (3-4 n-m/ 26-35 in-lbs). Step 10.8

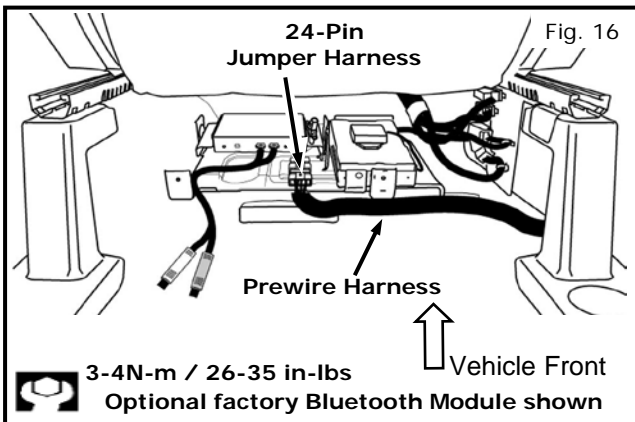

10.9) Connect factory prewire harness to 24-pin jumper harness under passenger seat. Figure 16

10.10) Remove and dispose of passenger headrest by pressing release button on seat post guide, and pulling up on headrest. Figure 17

**NOTE: Seat position may need to be adjusted for the removal of the factory headrest and installation of the DVD headrest.**

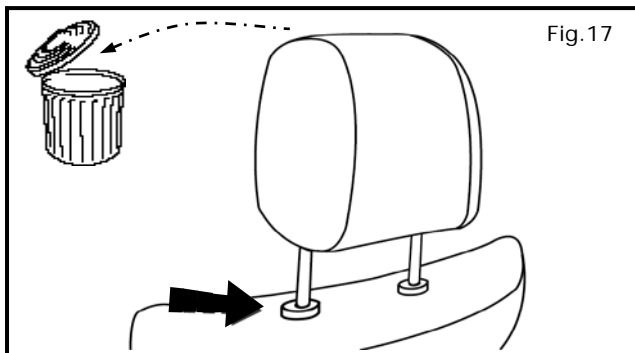

10.11) Disconnect two straps holding seat back apron to underside of passenger seat. Figure 18

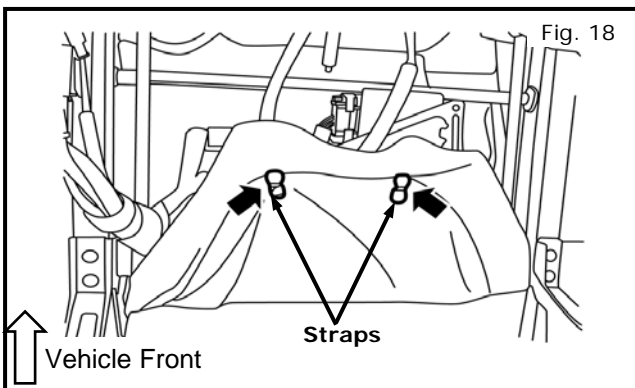



**INSTALLATION PROCEDURE: PASSENGER SIDE (continued)**

**NOTE: Use caution when inserting the DVD headrest posts to prevent damage/scratching of seat post guides and seating surface.**

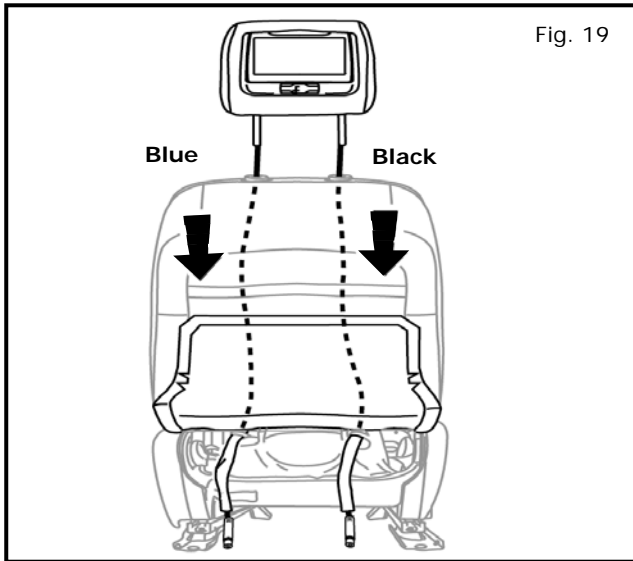

- 10.12) Insert passenger DVD headrest cables ( blue / black) into seat post guide holes of passenger seat as shown. Continue routing cable down through seat back and out through bottom of seat. Figure 19

**NOTE: When installing passenger DVD headrest cables, it is important that DVD screen is positioned correctly. DVD screen must face rearward.**

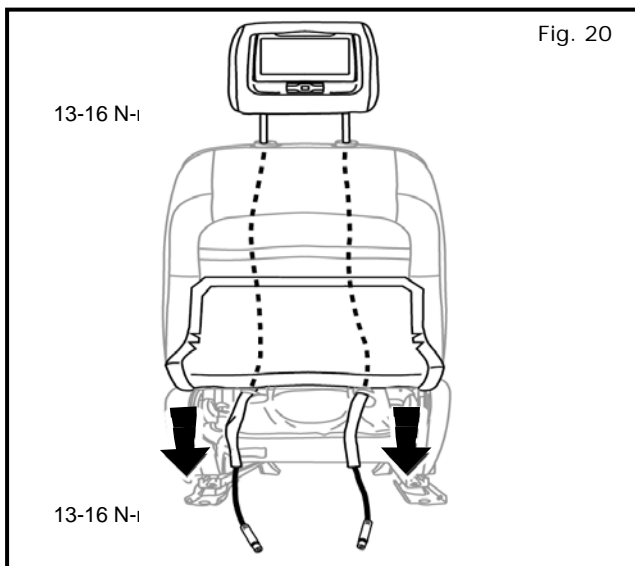

- 10.13) Insert passenger DVD headrest posts into seat post guides. Lock DVD headrest into its highest position (Bottom-Most Notch). Figure 20
- 10.14) Pull on two headrest cables from seat bottom to remove all slack. Figure 20

**NOTE: Perform cable connection steps, 10.15 through 10.18, as noted to install DVD Headrest correctly for proper operation.**

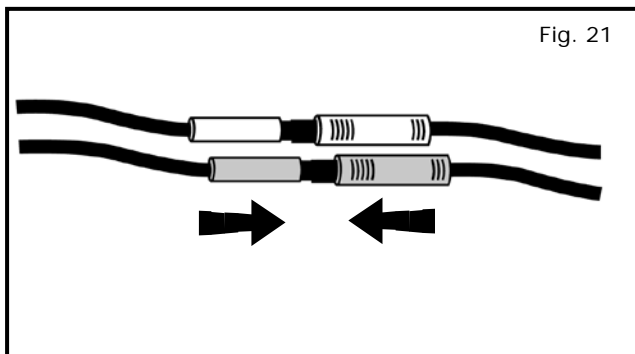

- 10.15) Connect blue and black barrel connectors to matching blue and black barrel connectors of DVD harness. Figure 21

**INSTALLATION PROCEDURE: PASSENGER SIDE (continued)**

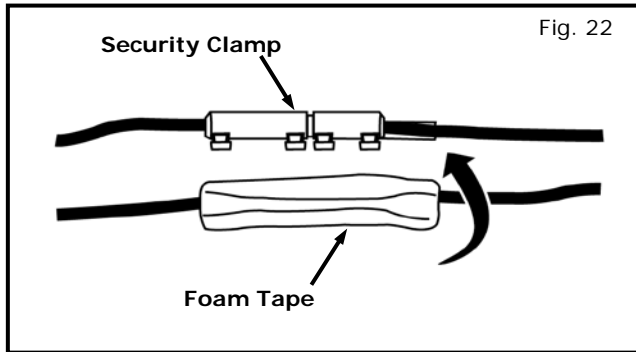

10.16) Secure barrel connectors using two security clamps. Place blue barrel connectors into one security clamp and lock closed. Place black barrel connectors into second security clamp and lock closed. Figure 22

10.17) Apply one piece of foam tape over each security clamp. Figure 22

**NOTE: Before tightening wire ties, reconnect battery and exercise seat to ensure wiring does not interfere with seat movement. Disconnect battery when complete.**

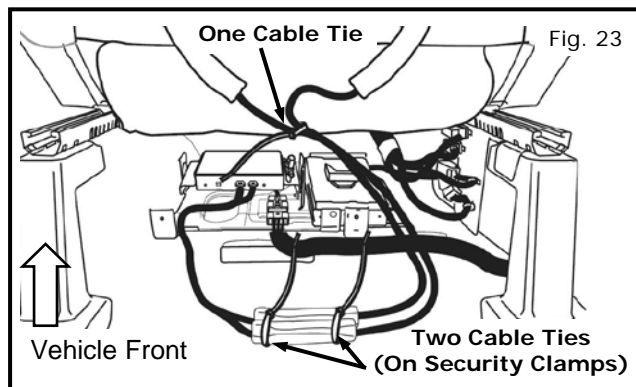

10.18) Use three cable ties to secure headrest cables.

- a) Group headrest cables to center of seat and secure using one cable tie. Figure 23
- b) Use two cable ties to secure foam wrapped barrel connections. Figure 23

**NOTE: Place cable ties over the foam tape about a half-inch (1/2") from the ends.**

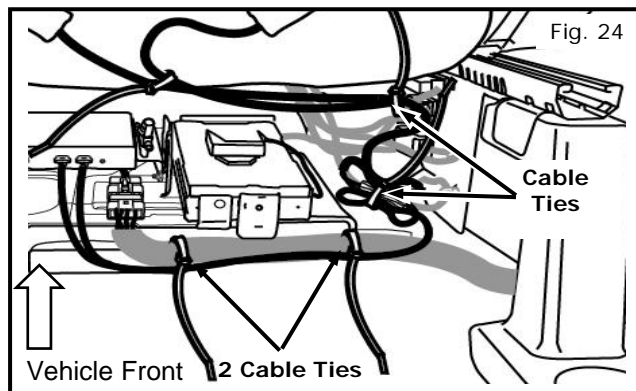

10.19) Continue routing headrest cables toward passenger door and secure to factory wiring using one cable. Figure 24

10.20) Use four cable ties to secure headrest cables and cables slack to factory wiring harness. Figure 24

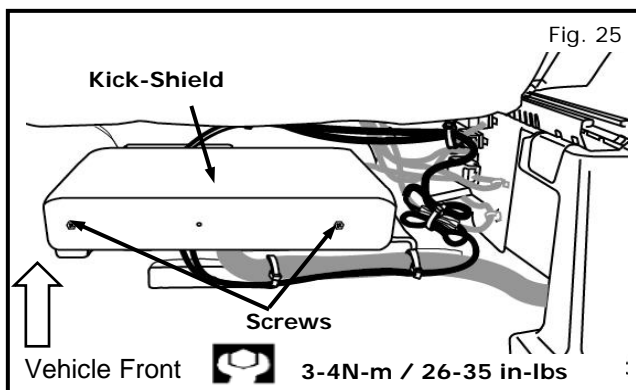

10.21) Reinstall kick-shield using a Phillips screwdriver and screws removed in Step 10.1. Figure 25

- a) 1/4" Phillip Tip Socket for Phillip Screws (3-4m / 26-35 in-lbs). Step 10.21

10.22) Using diagonal cutters, cut all excess wire ties.

10.23) Reattach seat apron straps.

## INSTALLATION PROCEDURE: RECONNECT BATTERY

### 11) Reconnect Battery Terminal Connection

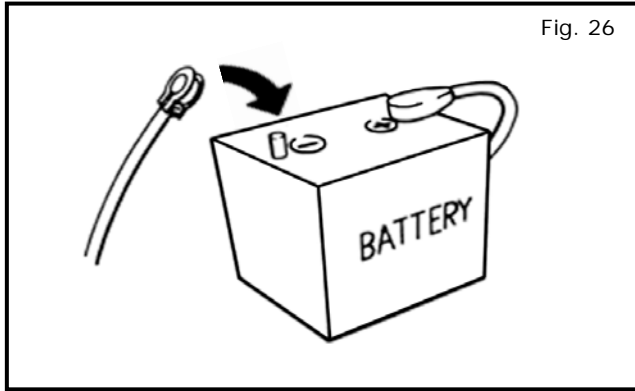

- 11.1) Reconnect battery terminal cable connection. Figure 26
- 11.2) Set driver and passenger seats to Full Up and Rearward position.

## ACCESSORY CHECK:

- Connect battery negative terminal and tighten nut to 5.4 N-m (47.8 lb-in).
  - Check all Critical Installation Steps.
    - 10.7) Using a ratchet and 8mm socket, install three M5 bolts to attach Control Module Assembly to factory accessory mounting bracket. Figure 15
      - a) 8mm socket for M5 Bolts (4.0N-m / 35 in-lbs). Figure 15
    - 10.8) Reinstall factory Bluetooth Module into factory accessory mounting bracket using three screws removed in step 10.4
      - a) 1/4" Phillips Tip Socket for Phillips Screws (3-4N-m / 26-35 in-lbs). Step 10.8
    - 10.21) Reinstall kick-shield using a Phillips screwdriver and screws removed in step 9. Figure 25
      - a) 1/4" Phillips Tip Socket for Phillips Screws (3-4N-m / 26-35 in-lbs). Figure 25
  - Verify all wiring is secure and not exposed.
  - Trim all excess cable ties flush.
  - Turn ignition switch to "ACC" position.
  - Confirm accessory main features and functions. Diagnostic flow chart is available on page 14 for troubleshooting.
    - Press power button on each DVD Headrest Monitor to verify backlighting illuminates and displays NISSAN Logo.
    - Insert a DVD into each DVD Headrest Monitor to verify DVD players accept discs.
- NOTE: Supplied is a dual function Remote Control used to control each DVD Headrest Monitor independently. Press "DVD-A" button to use remote control to operate Driver side DVD Headrest Monitor. Press "DVD-B" button to use remote control to operate Passenger Side DVD Headrest Monitor.**
- Press Play button on remote control to verify DVD video is displayed on LCD monitors.
  - Press Power button and AUX button on radio to verify audio from Driver Side DVD Monitor can be heard through vehicle speakers.

**ACCESSORY CHECK: (continued)**

**NOTE: Supplied Wireless Headphones are equipped with a A-B switch to select audio from either Driver Side DVD Headrest Monitor (CH A) or Passenger Side DVD Headrest Monitor (CH B). When sitting in-front of Driver Side DVD Headrest Monitor, use CH A switch setting. When sitting in front of Passenger Side DVD Headrest Monitor, use CH B switch setting.**

- Press and release Power button on wireless headphones to verify audio from DVD can be heard through headphones.
- Press STOP button on remote control to verify DVD disc stops playing.
- Press EJECT button on each DVD player to verify DVD players eject discs properly.
- Check all vehicle electrical systems that accessory interfaces with.
  - Vehicle electrical system 1
  - Vehicle electrical system 2

**FINAL INSPECTION:**

- Verify vehicle headliner, seat, steering wheel, center console, floor carpets, etc. are not soiled.
- Verify interior and exterior is not damaged.
- Turn ignition switch to "ON" and confirm proper operation of Vehicle Systems.
  - If equipped, verify all window and sunroof one touch operation and perform the reset procedure if necessary. Refer to vehicle service manual for more details.
  - Confirm proper audio function (AM, FM, SAT, CD and AUX).
- Re-program radio presets and other vehicle settings to the recorded settings.
- Start engine and verify that there are no new Diagnostic Trouble Codes. Turn ignition switch to "OFF".
- Place Customer Prepack inside center console bin.
- Return vehicle to shipping state.
- If this vehicle will be returned to a dealer lot or showroom for an extended period of time, be sure extended storage switch is placed in the "inventory" position.





## GENUINE PARTS SERVICE PARTS LIST

APPLICATION: ARMADA DUAL DVD HEADRESTRAINT MONITOR

PART NUMBER(S): Dual DVD Headreststraint Monitor Leather, (G;1) Charcoal - 999U8 2Z000  
 Dual DVD Headreststraint Monitor Leather, (Y;1) Almond- 999U8 2Z001  
 Dual DVD Headreststraint Monitor Leather, (G;1) Charcoal - 999U8 2Z002 (Platinum Grade)  
 Dual DVD Headreststraint Monitor Cloth, (G;1) Charcoal - 999U8 2Z005  
 Dual DVD Headreststraint Monitor Cloth, (Y;1) Almond - 999U8 2Z006

No.	Part Name	Description	Service Part Number
1	DVD HDRST MNTR DR	DVD Headreststraint Assembly, Leather (G;1) Charcoal	999U8 22010-01
		DVD Headreststraint Assembly, Leather (Y;1) Almond	999U8 22011-01
		DVD Headreststraint Assembly, Leather (G;1) Charcoal (Platinum Grade)	999U8 22012-01
		DVD Headreststraint Assembly, Cloth (G;1) Charcoal	999U8 22015-01
		DVD Headreststraint Assembly, Cloth (Y;1) Almond	999U8 22016-01
2	DVD HDRST MNTR AS	DVD Headreststraint Assembly, Leather (G;1) Charcoal	999U8 22010-02
		DVD Headreststraint Assembly, Leather (Y;1) Almond	999U8 22011-02
		DVD Headreststraint Assembly, Leather (G;1) Charcoal (Platinum Grade)	999U8 22012-02
		DVD Headreststraint Assembly, Cloth (G;1) Charcoal	999U8 22015-02
		DVD Headreststraint Assembly, Cloth (Y;1) Almond	999U8 22016-02
3	DVD HDRST DR	Headreststraint, Leather (G) Charcoal	999U8 2Z020-01
		Headreststraint, Leather (Y) Almond	999U8 2Z021-01
		Headreststraint, Leather (G) Charcoal (Platinum Grade)	999U8 2Z022-01
		Headreststraint, Cloth (G) Charcoal	999U8 2Z025-01
		Headreststraint, Cloth (Y) Almond	999U8 2Z026-01
4	DVD HDRST AS	Headreststraint, Leather (G) Charcoal	999U8 2Z020-02
		Headreststraint, Leather (Y) Almond	999U8 2Z021-02
		Headreststraint, Leather (G) Charcoal (Platinum Grade)	999U8 2Z022-02
		Headreststraint, Cloth (G) Charcoal	999U8 2Z025-02
		Headreststraint, Cloth (Y) Almond	999U8 2Z026-02
5	DVD MNTR DR Nissan (1)	DVD Monitor, DR, NISSAN (1)	999U8 X2030
6	DVD MNTR AS Nissan (1)	DVD Monitor, AS, NISSAN (1)	999U8 X2031
7	CTL ASSY Pre-Pack	Controller Assembly and Hardware	999U8 2Z040
8	DVD CTRL & BRK ASSY	Control Module, Bracket and Harness	999U8 2Z043
9	CUSTOMER PREPACK NISSAN (1&2)	Wireless Headphones (2), Remote Control, Owner's Manual and Quick Reference Guide	999U8 XZ075
10	WIRELESS HEADPHONE IR	Wireless Headphone, Infrared (universal)	999U8 VZ042
11	REMOTE CTL IR	Remote Control, Infrared (universal)	999U8 VZ044
12	OWNER MANUAL Nissan (1&2)	NISSAN Owner's Manual (English/French/Arabic)	999U8 XZ080
13	QUICK REFERENCE GUIDE Nissan (1&2)	NISSAN Quick Reference Guide (English/French/Arabic)	999U8 XZ081
14	INSTALL PREPACK	Cable Ties, Security Clamps, Foam Tape Strips and 16-Pin Jumper Harness, Driver	999U8 23070
15	HRN KIT	Harness Package, Complete System (DR-1; AS-2)	999U8 2Z060-SP

**NOTE: The images below depict the appearance of the parts listed above and are not exact representations of each part.**

