



GENUINE PARTS

INSTALLATION INSTRUCTIONS

DESCRIPTION:	Cargo Organizer
APPLICATION:	Leaf
PART NUMBER:	999C2 8Z000 (Gray) 999C2 8Z010 (Black)

KIT CONTENTS:

Item	Qty.	Part Description	Service Part Number
A	1	Cargo Bin	Not Available
B	2	Dividers	Not Available
-	-	Installation Hardware Kit	Not Available
C	1	• Jack nut	Not Available
D	1	• Jack nut installation tool	
E	1	• Bolt (Hex 10-24)	
F	1	• Knob	
G	2	• Spacer	
H	1	Installation Instruction Replacement Template	999V2 AW000

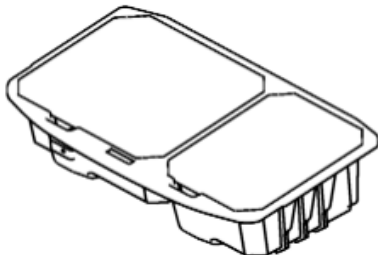

A

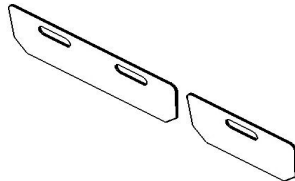

B

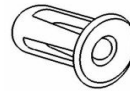

C

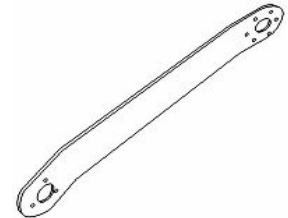

D



E

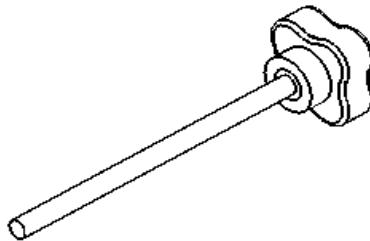

F

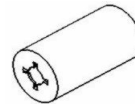

G



Dealer Installation Recommended.

WARNING

To avoid serious personal injury or property damage, obtain the Installation Instructions before attempting to install this accessory. The Installation Instructions provide the necessary procedures for a safe installation.

CUSTOMER INTERNET DOWNLOAD INSTRUCTIONS: Customers can obtain Installation Instructions for Infiniti or Nissan vehicles at www.Infiniti-TechInfo.com or www.Nissan-TechInfo.com respectively. From the home page, click on "Inside Publications" and select Accessory Installations. Select your model and model year, then locate the instructions for your accessory.

DEALER ASSIST DOWNLOAD INSTRUCTIONS: Dealership technicians can locate the Installation Instructions for this accessory in **ASIST/INFO TOOLBOX**. Always download and use latest version of the Installation Instructions.

Installation Instructions Pajajaran Timor 999C2 AW000 Rev. 09/21/09

H

TOOLS REQUIRED:

- 5/16" socket & driver
- Clip removal tool
- Drill Motor
- 3/8" Drill bit

PRE-INSTALLATION WARNINGS, CAUTIONS, CRITICAL STEPS, and NOTES:

 WARNING

- Cargo organizer is designed to transport normal cargo contents. Flammable or dangerous materials should not be transported in your vehicle at any time. If any corrosive chemicals are spilled in your organizer it should be cleaned as described below.

 CAUTION

- Organizer does not provide load restraint.
- Maximum load of 150lbs (68Kg).
- Do not overtighten hand knob.

NOTE:

- DEALER - Provide these installation instructions to the customer as reference for proper operation and care of this unit.
- Dealer Installation Recommended. Instructions may refer to Service Manual.
- To maintain the luster of the plastic bin in your organizer, clean with a cloth as required using standard automotive vinyl, leather and upholstery cleaners or soap and water.
- Care should be taken to avoid damaging the interior panels while installing or removing the organizer. Do not use sharp tools to remove trim or weatherseal.

INSTALLATION PROCEDURE:

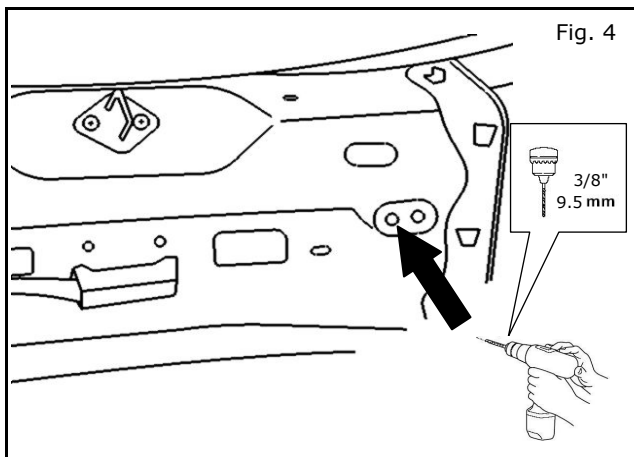
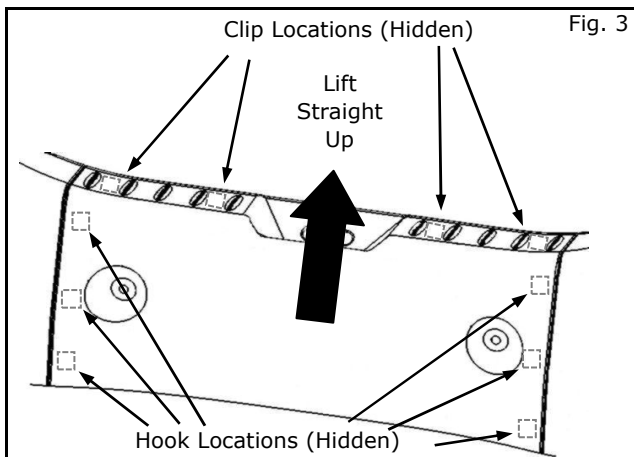
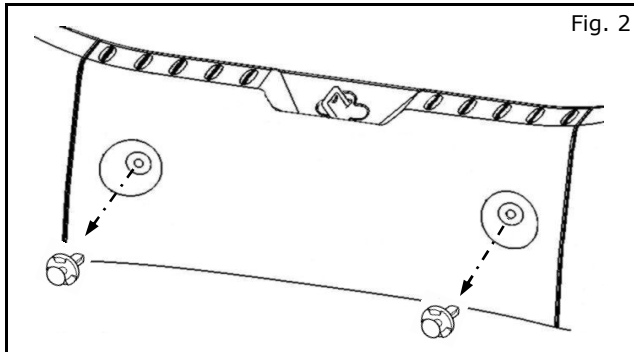
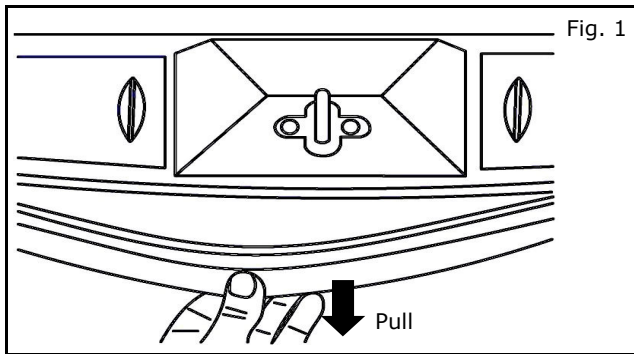

- 1) Remove parcel shelf and any contents in cargo area.
- 2) Gently pull weatherseal away from rear plastic trim plate.

- 3) Remove 2 rear trim clips.

Critical Steps: The following steps 4) and 5) are critical and must be performed **EXACTLY** as specified to ensure proper installation.

NOTE:

• Failure to lift trim straight up will result in broken hooks.

- 4) Remove trim by using clip removal tool to disengage 4 top clips.
- 5) Disengage hooks by lifting trim straight up.
- 6) Drill out **driver side** hole where plastic trim clip was located using a 3/8" bit.
- 7) Deburr hole and apply rust preventative or touch up paint.

INSTALLATION PROCEDURE: (continued)

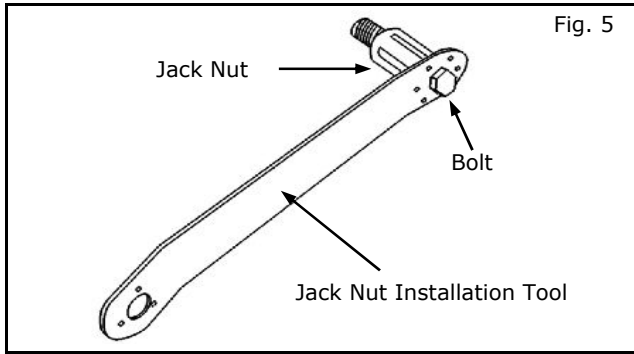

- 8) Place bolt through hole in jack nut installation tool and thread jack nut on bolt.

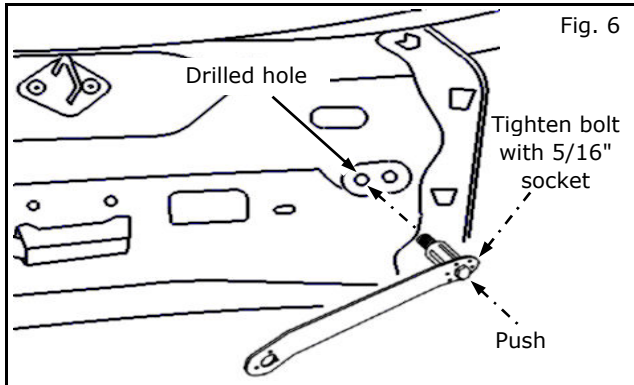

- 9) Push jack nut into drilled hole and tighten bolt with 5/16" socket & driver.

NOTE:

- Apply constant pressure to keep nut against sheet metal.

- 10) Secure jack nut to sheet metal by securing bolt. After, remove bolt by loosening.

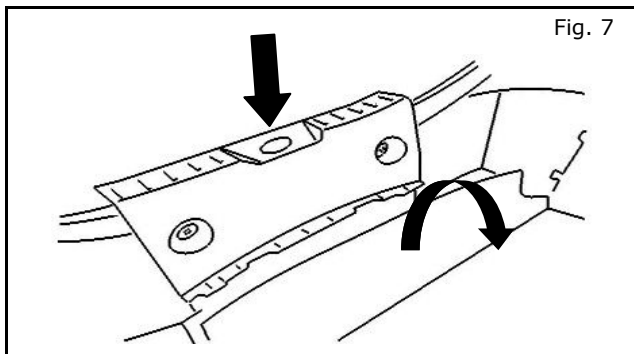

- 11) Lift load floor and reinstall rear trim.

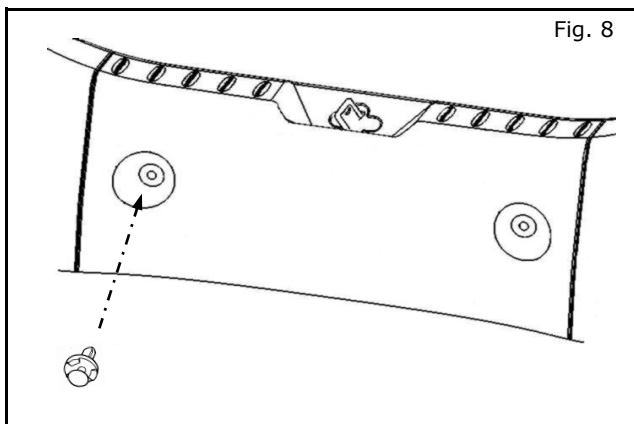

- 12) Reinstall plastic trim clip in passenger side hole.

INSTALLATION PROCEDURE: (continued)

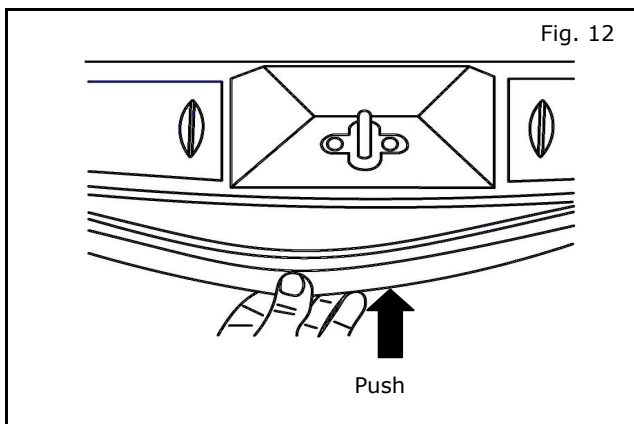
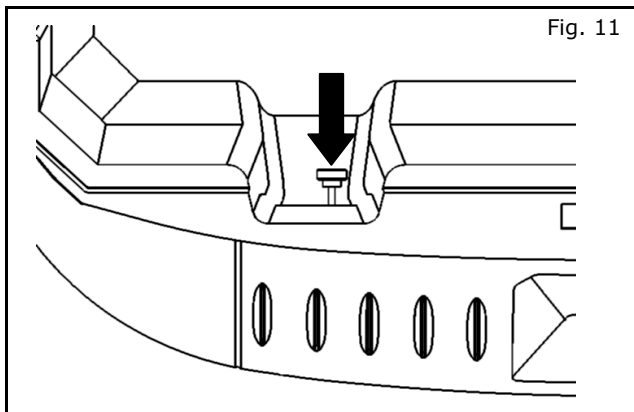
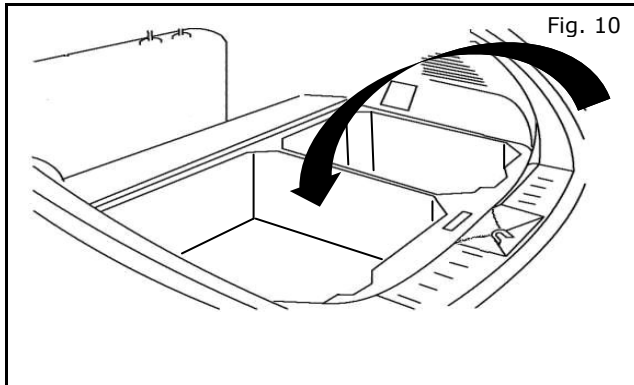
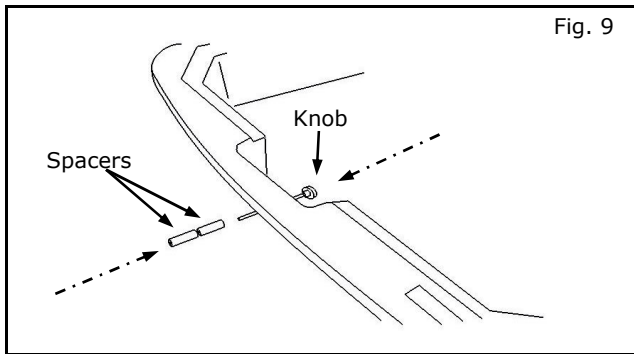

- 13) Insert knob with threaded stud through hole in inside rear of cargo organizer (driver side only) and push 2 spacers onto stud.
- 14) Place spacers so end of stud is covered.
- 15) Push spacers against cargo organizer.
- 16) Slide cargo organizer into rear trunk well.
- 17) Align knob stud with jack nut hole and screw until hand tight against spacers.

⚠ CAUTION

- Turn knob **ONLY** until resistance is felt from the spacers. Do not overtighten knob.
- Maximum bin load of 150lbs (68Kg)

- 18) Reinstall trunk weatherseal.

INSTALLATION PROCEDURE: (continued)

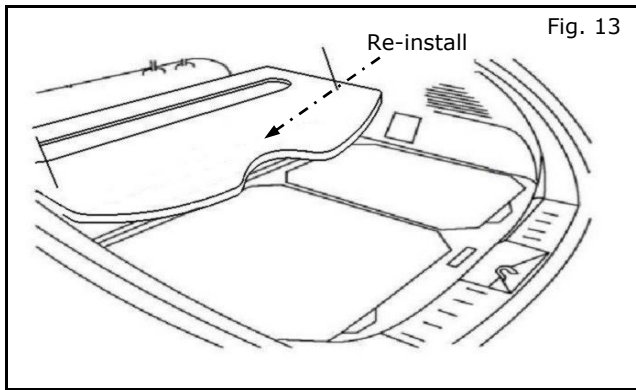

- 19) Reinstall parcel shelf once cargo bin is secured (if applicable).

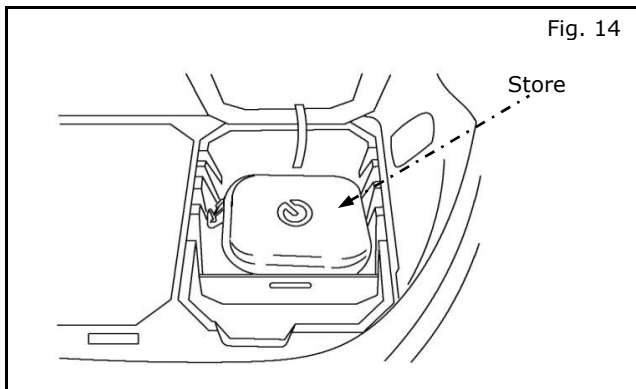

- 20) Store charge kit in small bin.