



INFINITI®

# GENUINE PARTS

## INSTALLATION INSTRUCTIONS

1. **DESCRIPTION:** Tow Hitch Finisher

2. **APPLICATION:** Pathfinder

3. **PART NUMBER:** 999T5 RZ040

Installation of this accessory first requires installation of additional parts:

- Trailer Tow Harness: 999T8 XZ000

### 4. KIT CONTENTS:

Item	QTY	Description	Service Part Number
A	1	Tow Hitch Finisher	"Not Available"
B	1	Cutting Template	"Not Available"
C	1	3M™ Adhesion Promoter 4298	"Not Available"
D	2	Spring Nut	"Not Available"
E	2	Screw	"Not Available"
F	3	Spring Clip	"Not Available"
G	1	Installation Instructions Replatement Template	999V2 AW000

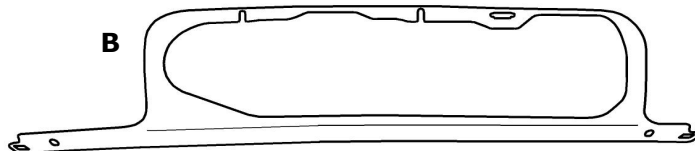
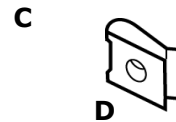
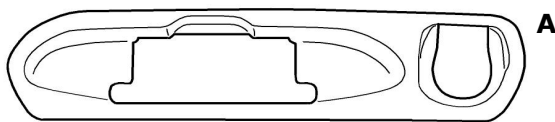

G

**Important: Read Before Installation!**

Dealer Installation Recommended.

**WARNING**  
To avoid serious personal injury or property damage, obtain the installation instructions before attempting to install this accessory. The installation instructions provide the necessary precautions for a safe installation.

**CUSTOMER INTERNET DOWNLOAD INSTRUCTIONS:** Customers can obtain installation instructions for Infiniti or Nissan vehicles at [www.infiniti-technika.com](http://www.infiniti-technika.com) or [www.nissan-technika.com](http://www.nissan-technika.com) respectively. From the home page, click on "Service Publications" and select "Accessory Installation". Select your model and model year, then locate the instructions for your accessory.

**DEALER ASSIST DOWNLOAD INSTRUCTIONS:** Dealership technicians can locate the installation instructions for the accessory in ASSIST LUNDO TOOLBOX. Always download and use the latest version of the installation instructions.

Infiniti Technical Publications Template 9999 AW000 Rev. 08/10/10

### 5. TOOLS REQUIRED

- Small reciprocating air saw with small fine-tooth blade
- Clean, Lint-free cloth
- 90% or greater isopropyl alcohol
- Drill with 8mm & 6mm Drill Bits
- Flathead Screwdriver
- Phillips Screwdriver
- Utility Knife
- Protective Gloves
- Masking tape
- Safety Glasses

### 6. PRE-INSTALLATION CAUTION/NOTES

- Dealer installation recommended. Instructions may refer to Service Manual
- Installation may require special tools
- This part is to be installed at a surface temperature no warmer than 65-100°F

## CAUTION

- This accessory must only be installed as specified in these instructions.
- Ensure at all times that parts are securely fitted and will not compromise the safe function of vehicle systems.

# INSTALLATION INSTRUCTIONS - Rear Hitch Cover Kit

## 7. INSTALLATION OVERVIEW

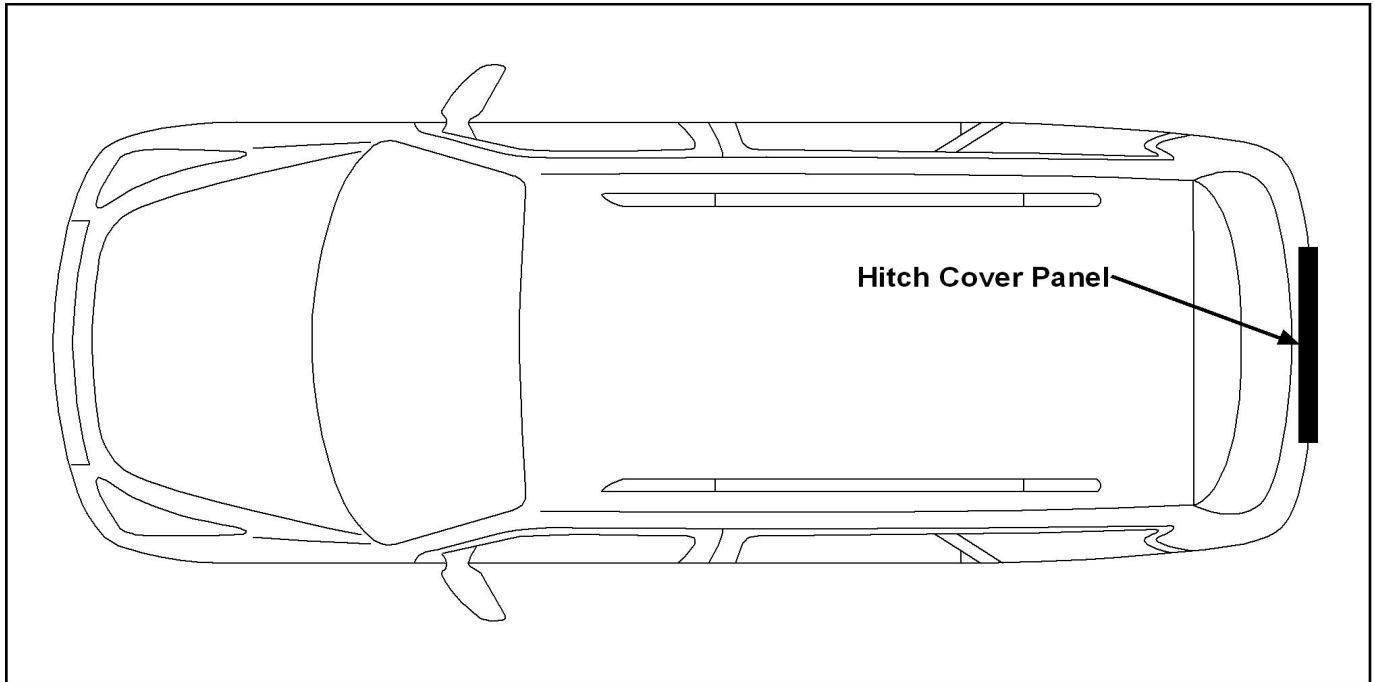

## 8. CRITICAL STEPS

The following steps are critical and must be performed **EXACTLY** as specified to ensure proper installation:

- Location of the cover panel must be followed exactly as described in this instruction.
- Be sure to apply masking tape as needed in order to protect any areas that may become scratched or damaged.
- Test the functionality of the kit before final clean up.

## 9. Order of Installation

1. Mount template.
2. Cut hole for Cover Panel.
3. Mount Cover Panel.

# INSTALLATION INSTRUCTIONS - Rear Hitch Cover Kit

## 10. INSTALLATION PROCEDURE

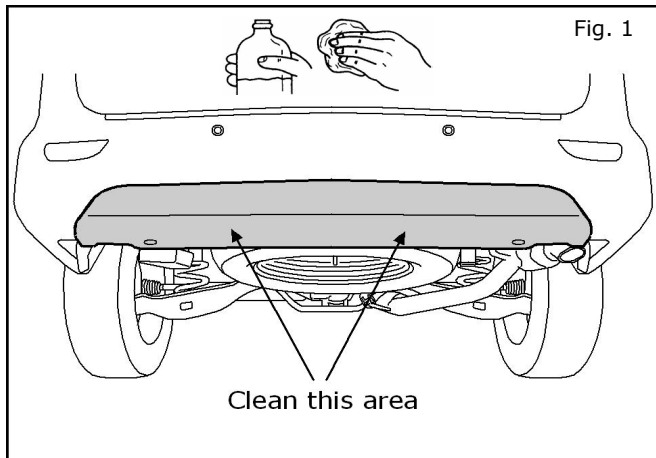

**NOTE: Before starting, confirm installation of the following part has been started before proceeding further:  
Trailer Tow Harness (999T8 YZ000)**

- 1) Raise Vehicle on hoist to working height.
- 2) Use a clean, lint-free cloth to clean the installation surface (shaded area) with isopropyl alcohol and water solution. Use at least 90% alcohol solution.
  - a) Allow the alcohol to dry completely.

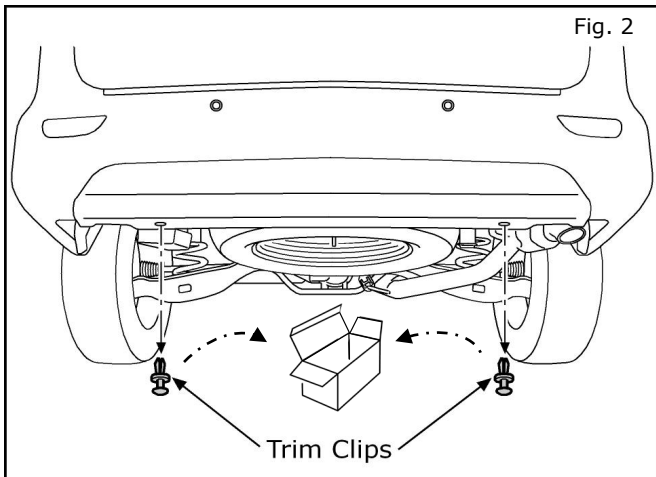

- 3) Use a flathead screwdriver to remove two (2) trim clips from the under side of the bumper.
  - a) Save trim clips for next step.

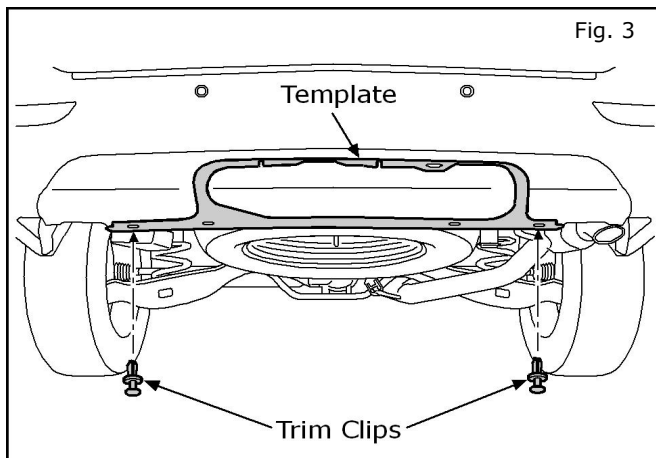

- 4) Position the cutting template to the rear bumper by lining up the trim clip holes on the bumper and cutting template, as shown in Fig 3.
  - a) Reinstall the two (2) trim clips previously removed in step 2.
  - b) Push firmly on clips to ensure they are properly located.

# INSTALLATION INSTRUCTIONS - Rear Hitch Cover Kit

## 10. INSTALLATION PROCEDURE

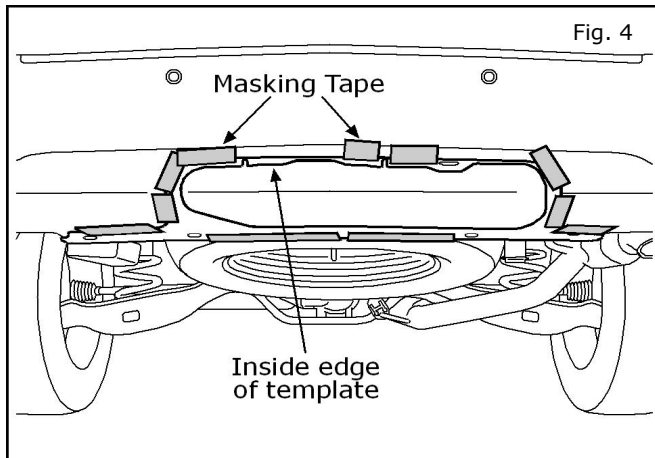

**NOTE: Apply pressure to be sure template is positioned firmly against the bumper surface.**

- 5) Apply masking tape around all outside edges of template to secure it to bumper, as shown in fig 4.

### ⚠ CAUTION

- Safety glasses required beyond this step

- 6) Drill holes as shown in Fig 6.
- a) Use an 6.0mm bit to drill Eight (8) holes at the positions shown. See Detail A & B.
  - b) Move in slot up and down in vertical slot and side to side in horizontal slot to obtain a uniform slot.
  - c) Use an 8mm (5/16") bit to drill Two (2) holes at the positions shown.

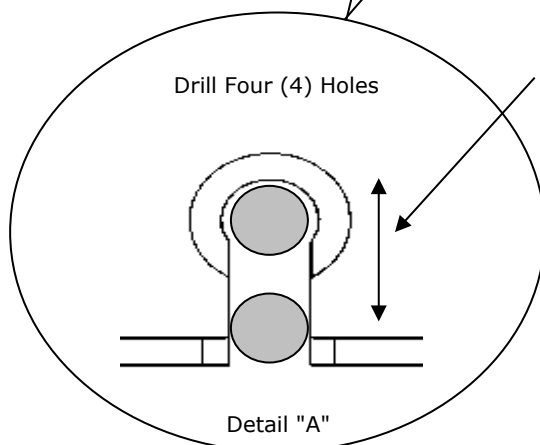
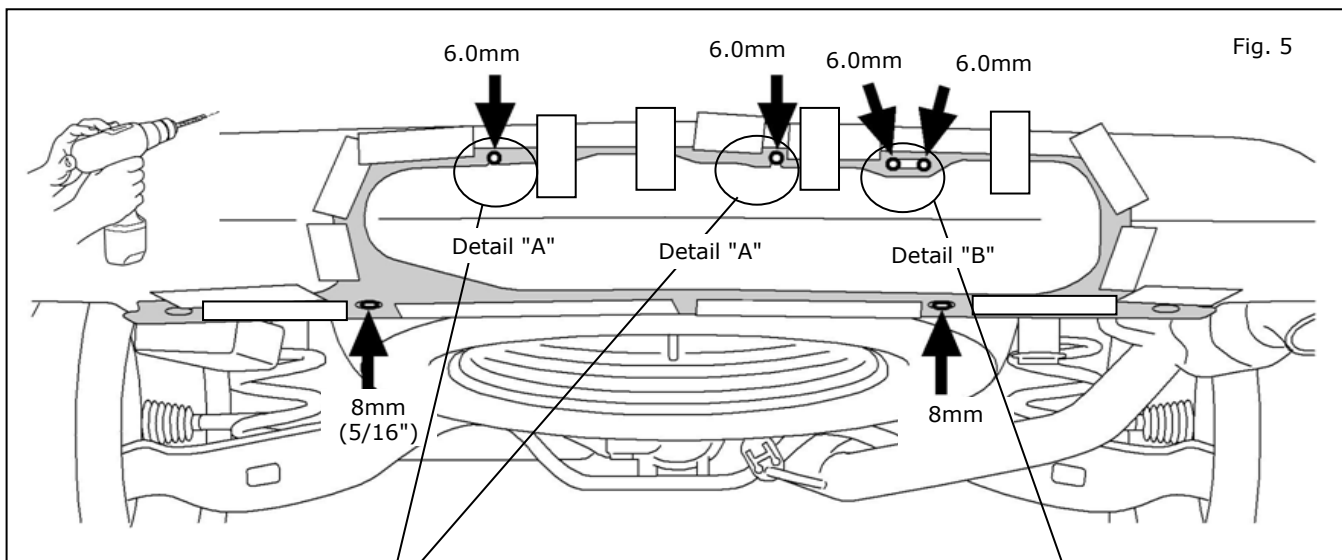

After Drilling, move drill up and down to obtain a uniform slot.

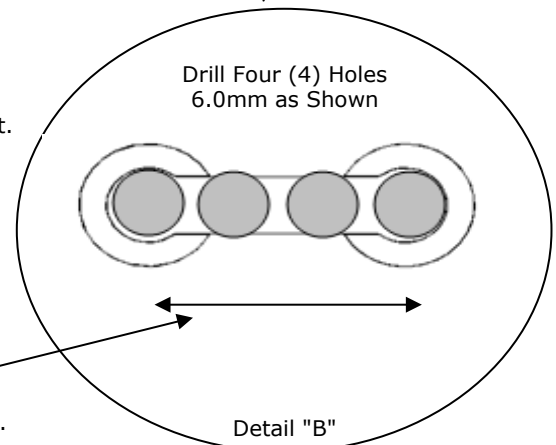

After Drilling, move drill side to side to obtain a uniform slot.

# INSTALLATION INSTRUCTIONS - Rear Hitch Cover Kit

## 10. INSTALLATION PROCEDURE

- 7) Remove any tape that covers inside edge of template.
- 8) Drill holes at locations shown in Fig 6 using 8mm (5/16") bit. This will help cutting process in the following steps.

**NOTE: Be sure Drill Bit is slightly below edges template.**

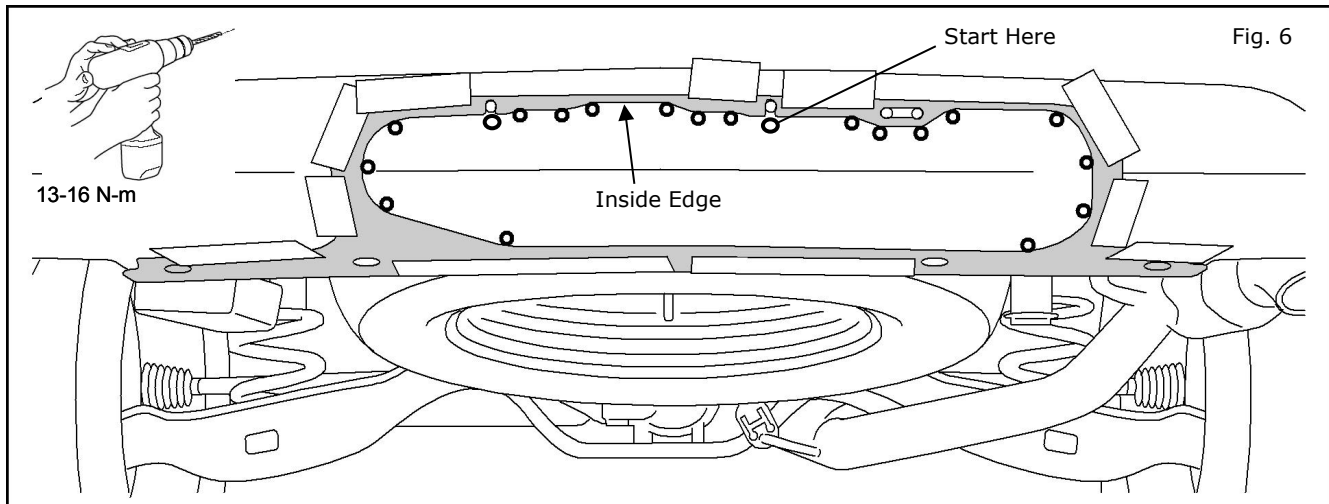

- 9) Use a small reciprocating air saw to cut the bumper plastic and connect the holes previously drilled in step above. Follow the edge of the template and work carefully from one hole to the next until complete.

**NOTE: Move slowly and firmly to keep the bit against the cutting template.**

## CAUTION!

Be aware of vehicle parts behind bumper in this area.

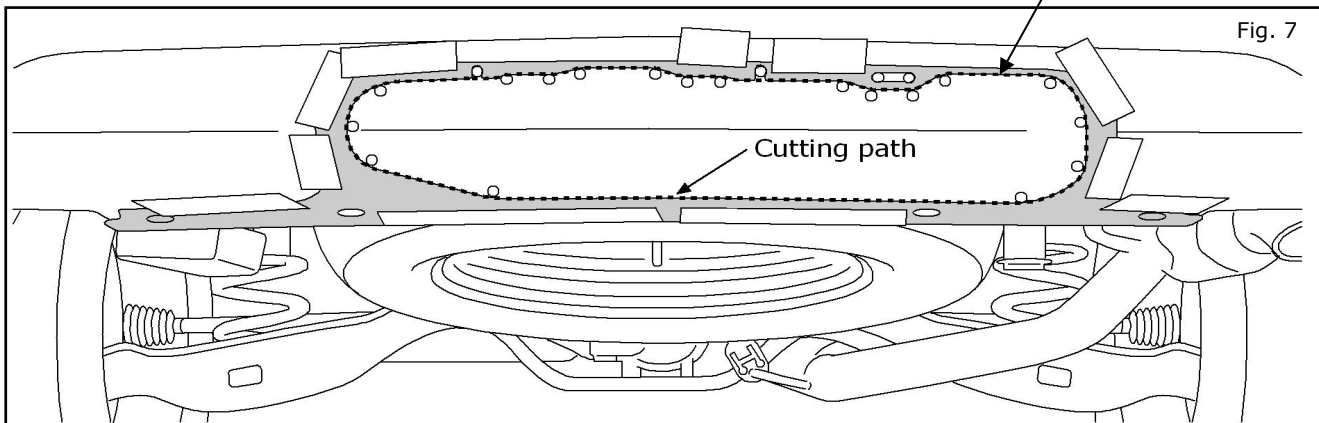

- Leave template in place and use utility knife to cut away burrs and cut excess bumper to be even with inside edge of Finisher.
- Use knife to clean and cut edges of slot.

# INSTALLATION INSTRUCTIONS - Rear Hitch Cover Kit

## 11. INSTALLATION PROCEDURE

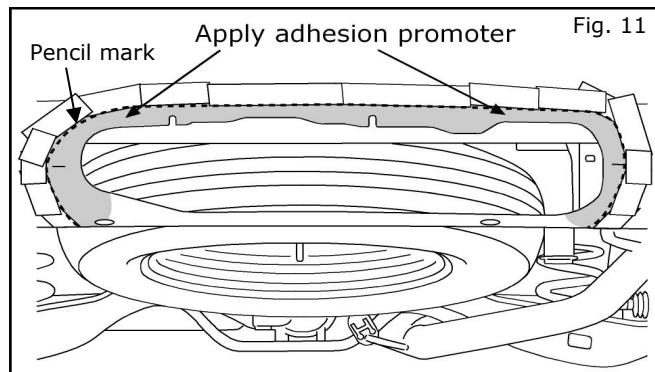
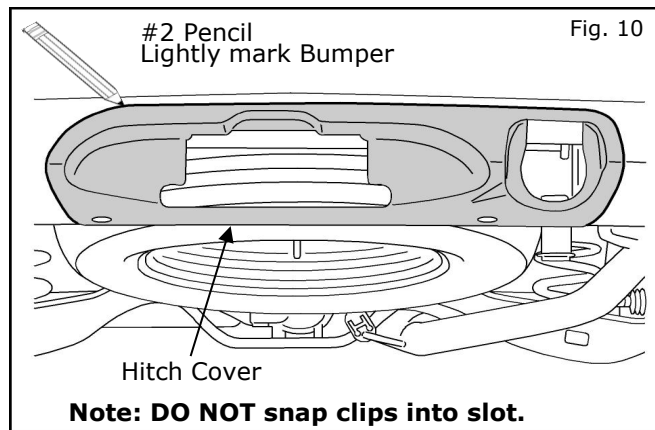
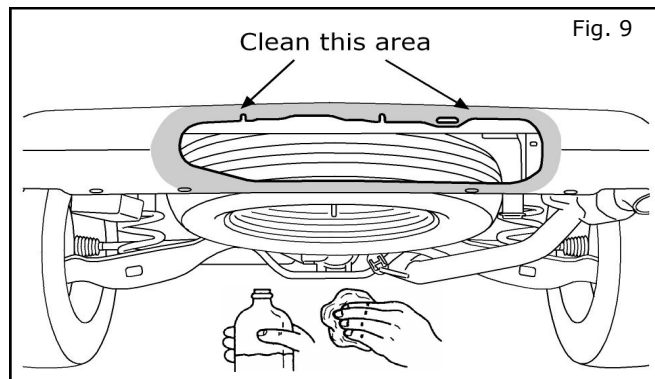
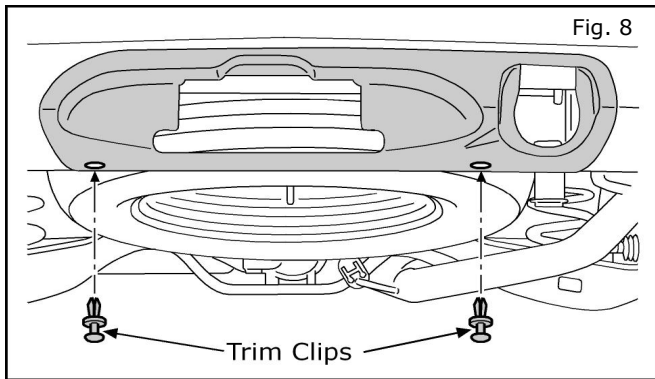

- 10) Remove the cutting template:
  - a) Remove all masking tape.
  - b) Use flathead screwdriver, remove the two trim clips from Template.
  - c) Re-install trim clips to attach bumper to brackets.

• **Carefully trim slots with knife.**

- 11) Use a clean, lint-free cloth and clean installation surface (shaded area) with isopropyl alcohol and water solution. Use at least 90% alcohol solution.

a) Allow the alcohol to dry completely.

- 12) Firmly position the Hitch Finisher against the bumper. The three tabs on the back of the Cover will align with attachment slots. Push and hold Finisher in upward position.

- 13) Use #2 pencil to lightly mark bumper as shown in Fig 10.

- 14) Remove Hitch Finisher.

- 15) Apply masking tape to slightly cover pencil mark as shown to protect visible areas from adhesion promoter. See Fig 11.

**NOTE: Tape should line up with pencil mark as shown.**

- 16) Apply Adhesion promoter to shaded area in Fig 11.

- a) Apply a thin, uniform coating to the shaded area, using the minimum amount to fully coat the surface.
- b) Remove the masking tape immediately.
- c) Wait two minutes and not more than one hour to complete installation.

**NOTE: Wear hand protection when working with adhesion promoter.**

# INSTALLATION INSTRUCTIONS - Rear Hitch Cover Kit

## 11. INSTALLATION PROCEDURE

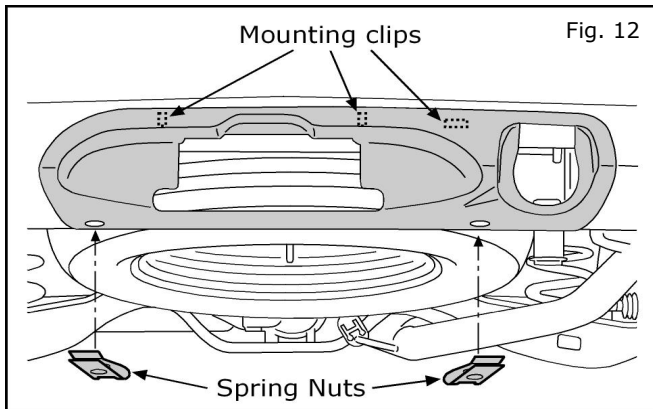

- 17) Install 3 Spring Clips onto mounting posts on back side of Finisher and 2 Spring Nuts over drilled holes on under side of Bumper.
- 18) Reposition the Hitch Cover against the bumper. Press firmly to engage all three (3) metal clips into the slots in bumper. Once clips are engaged push part upwards.

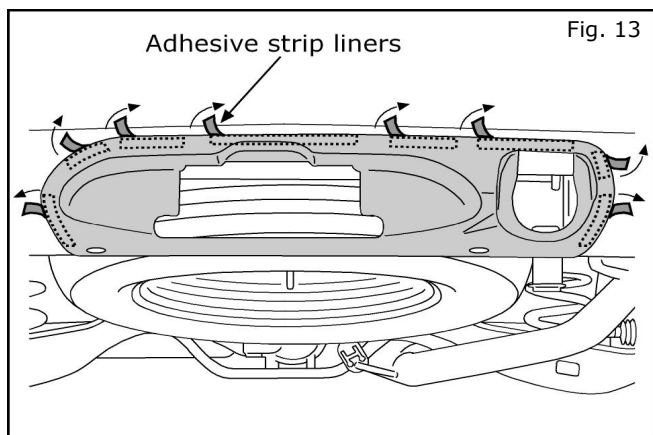

- 19) Carefully fold back pull tabs on tape so they are exposed per Fig 13.
- 20) Carefully lift the outer edges of the Hitch Cover to access the red tape liners. Firmly grip each liner and use a twisting motion to remove it from the adhesive strips inside the Cover.

**NOTE: Use a roller or burnish by hand to apply a minimum of 15lbs of pressure along length of tape (starting at top of part and working downward).**

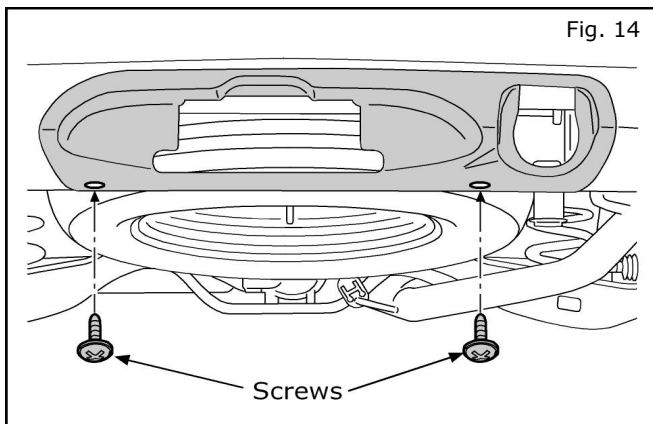

- 21) Install the two (2) Spring Nuts in the bottom of the Bumper prior to installing Finisher.
- 22) Install and tighten two (2) Screws to \_\_\_ Nm ( \_\_\_ in-lb) torque.

## **INSTALLATION INSTRUCTIONS - Rear Hitch Cover Kit**

### **12. CHECK OUT**

Inspect the vehicle for unfinished work.

- 1) Check the Hitch Cover for proper fit and finish. Be sure no gaps are visible.
- 2) Be sure all clips are securely fastened.



# INSTALLATION INSTRUCTIONS - Rear Hitch Cover Kit

## 16. BILL OF MATERIALS

### Rear Hitch Cover Kit - 999T5 RZ040

	Parts Contained in Bag Labelled 'Installation Kit'.	Qty	Part Number
1	Tow Hitch Finisher	1	"Not Available"
2	Cutting Template	1	"Not Available"
3	3M™ Adhesion Promoter 4298	1	"Not Available"
4	Spring Nut	2	"Not Available"
5	Screw	2	"Not Available"
6	Spring Clip	3	"Not Available"
7	Installation Instructions Replacement Template	1	999V2 AW000