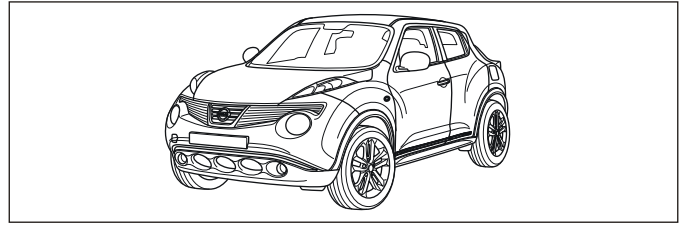


## Part Number

**KE610-BV260XX**  
(XX designates color)

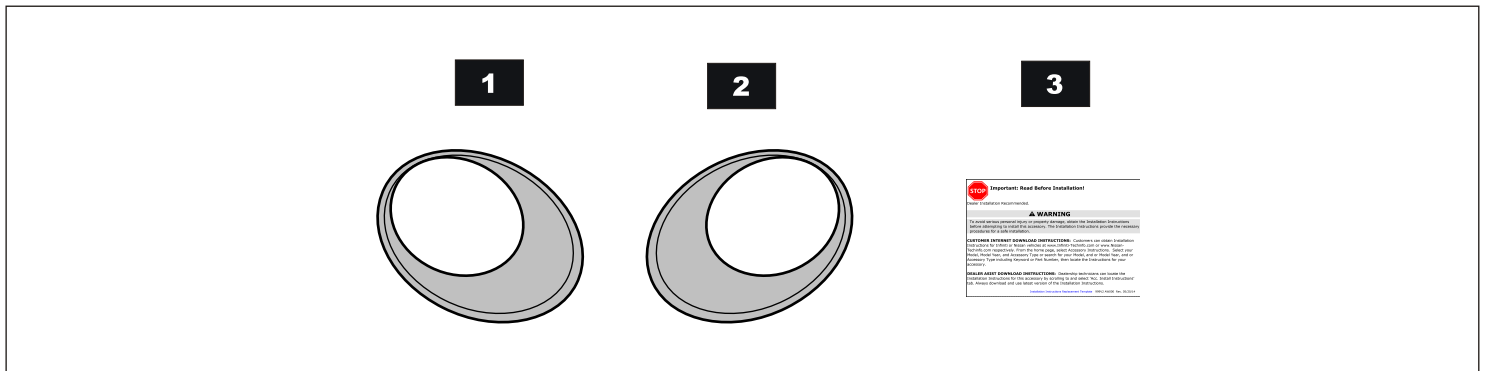
Juke F15  
Nissan International S.A.  
Made in Italy



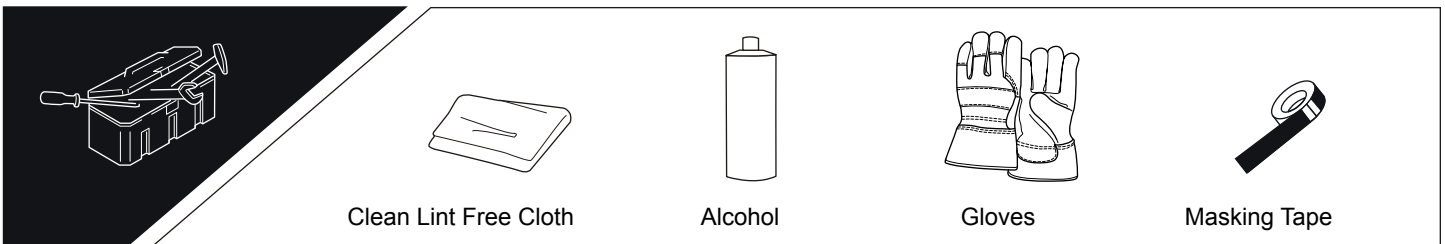
## Part Name: Headlamp Finishers - Painted

### LIST OF PARTS

No.	PART NAME	Q.TY
1	RHS Headlamp Finisher	1
2	LHS Headlamp Finisher	1
3	Installation Instruction Replacement Template	1



### TOOLS REQUIRED



### NOTE: Dealer Installation Recommended

### **CAUTION**

- Failure to clean mounting surface properly with alcohol will cause poor adhesion of part to vehicle.
- Do not wash or expose vehicle to a wet environment for 24 hrs after installing parts.

15°C, (59°F)

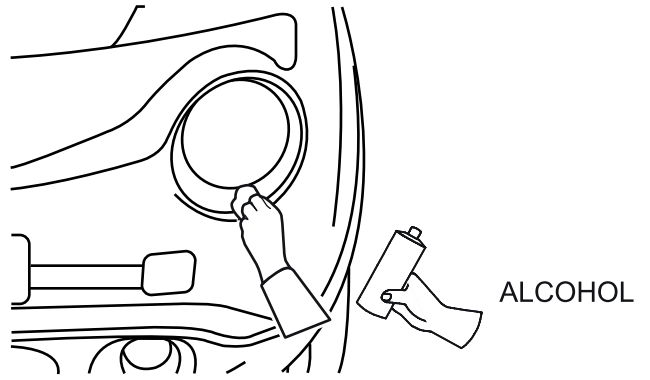
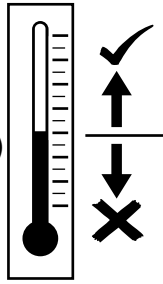


Fig. 1

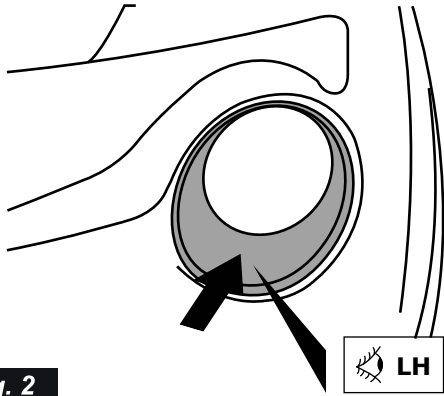


Fig. 2

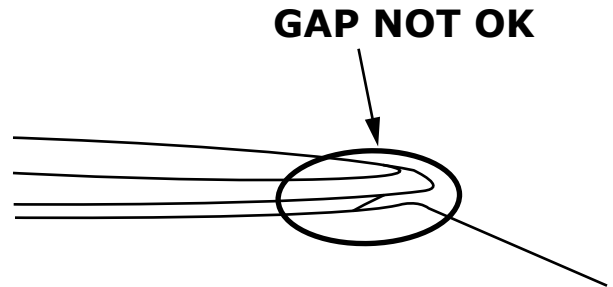
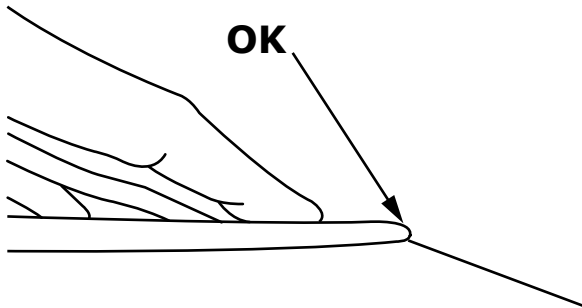
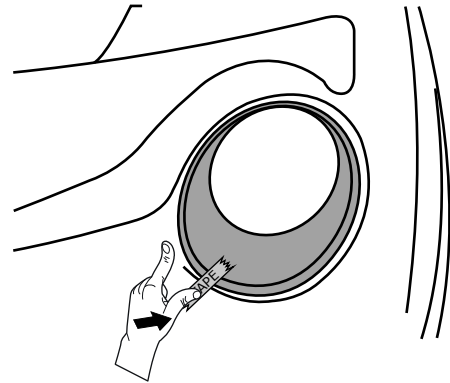


Fig. 3

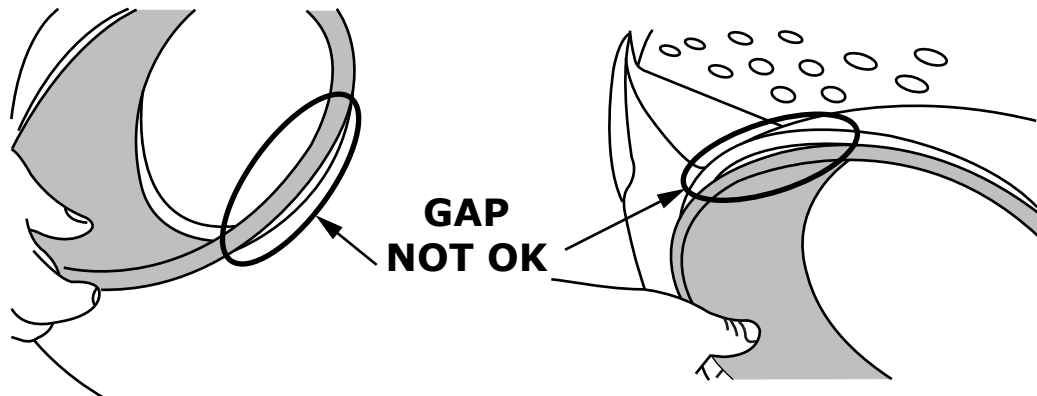
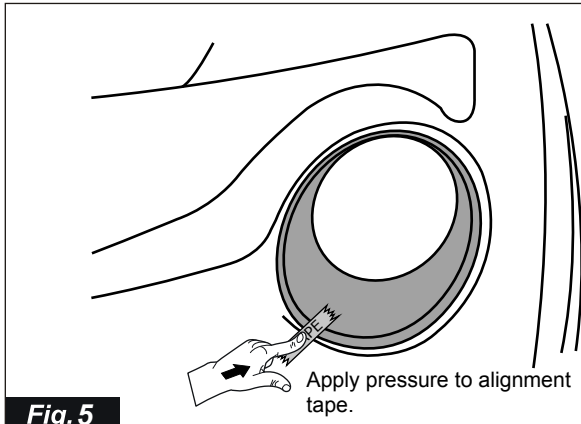
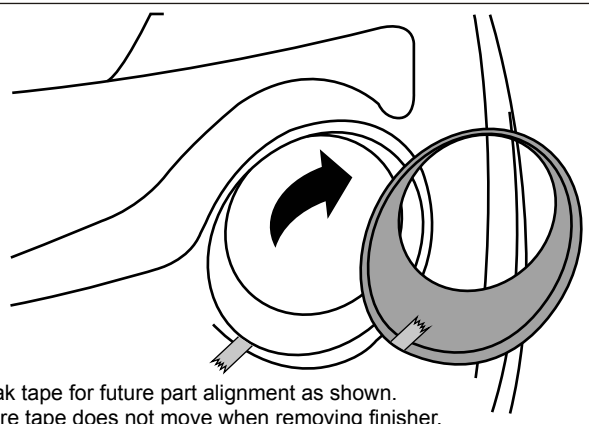


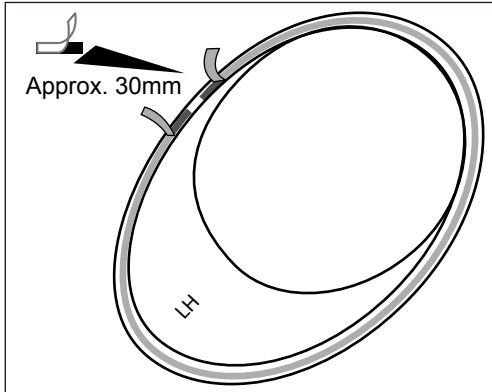
Fig. 4



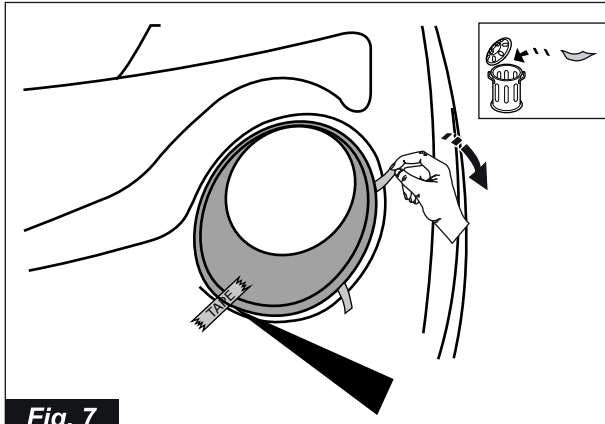
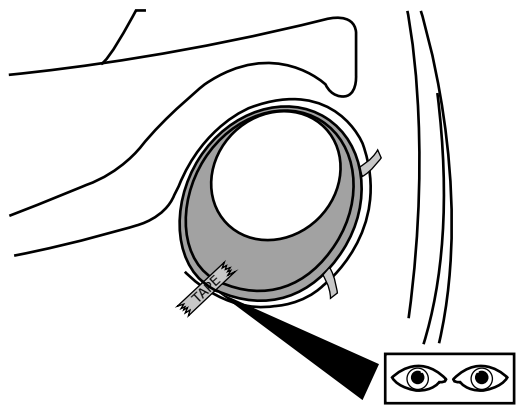
**Fig. 5**



\*Break tape for future part alignment as shown. Ensure tape does not move when removing finisher.

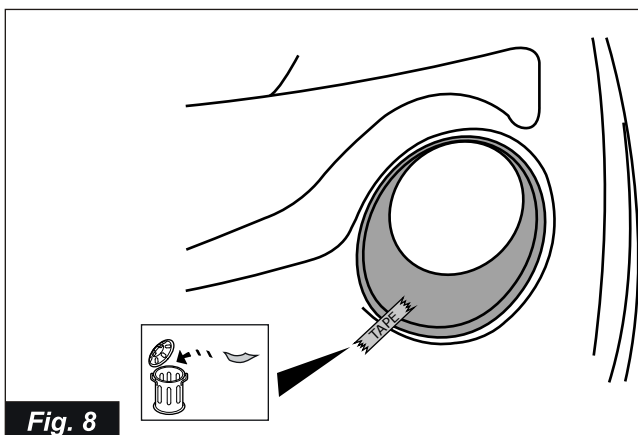
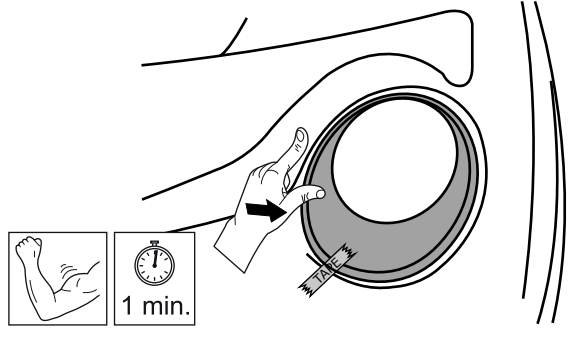


**Fig. 6**

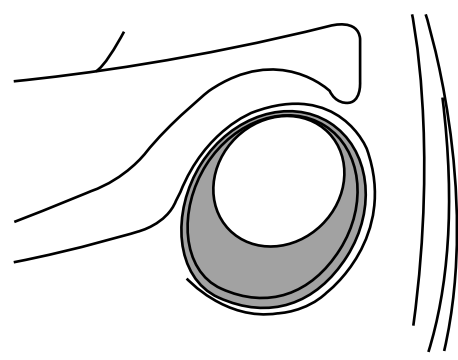


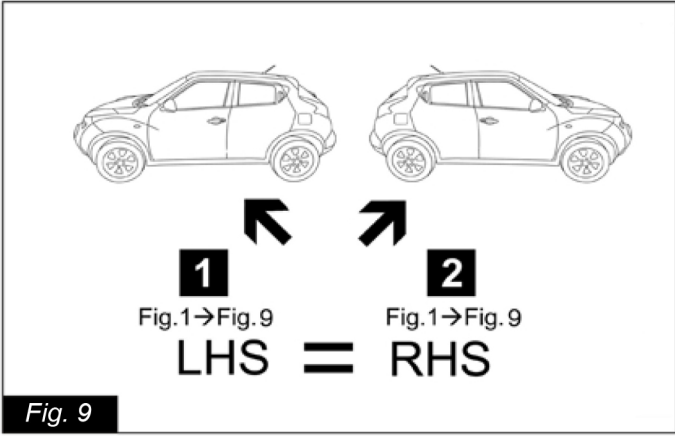
**Fig. 7**

\*MUST Apply uniform pressure of approx. 15-20 lbs over entire part and repeat a few times.



**Fig. 8**





**ACCESSORY CHECK:**

- Check and confirm gaps are uniform.
- Clean surrounding area near installed part.

**FINAL INSPECTION:**

- Verify exterior part is not damaged.
- Remove all tools/items from vehicle.