



GENUINE PARTS

INSTALLATION INSTRUCTIONS

DESCRIPTION:	Bed Tube Rails
APPLICATION:	Titan
PART NUMBER:	999T7-WQ900CC, 999T7-WQ900KC, 999T7-WQ600, 999T7-WQ350

KIT CONTENTS:

Item	Qty.	Part Description	Service Part Number
A	2	Side Rail Tube	n/a
B	4	Base	n/a
C	4	Mounting Bracket	n/a
D	4	Gasket	n/a
E	4	M8-1.25 X 40 Button Head Bolt	n/a
F	4	M8-1.25 X 60 Button Head Bolt	n/a
G	4	8mm Washer	n/a
H	1	Installation Instruction Replacement Template	999V2 AW000

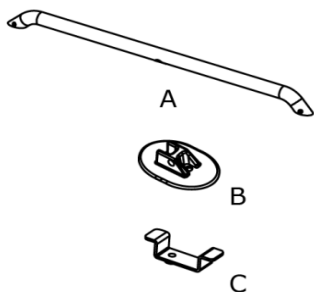

H



TOOLS REQUIRED:

- Ratchet (3/8" drive)
- 5mm Allen Head Drive
- Eye Protection
- Utility Knife W/Adjustable Depth
- Torque Wrench (Suitable for 35-45 in·lbs. & 16 ft·lbs.)
- Utility Knife w/Adjustable Depth
- Eye Protection

PRE-INSTALLATION WARNINGS, CAUTIONS, CRITICAL STEPS, and NOTES:

- Dealer Installation Recommended. Instructions may refer to Service Manual.

⚠ WARNING

- Be sure to properly adjust the depth of the utility knife when cutting the plastic at the stake pockets (Step 1).
- Damage to the vehicle paint may occur if the depth of the knife is not properly set when cutting.

INSTALLATION PROCEDURE:

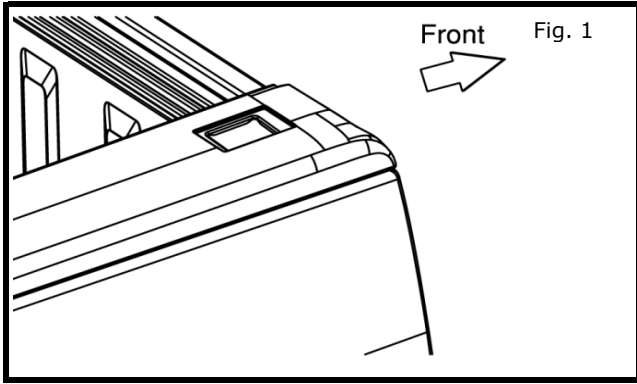

- 1) Using a utility knife with an adjustable depth of cut, set cut depth to 1.5mm, then cut out indented stake pocket locations (See Fig. 1).

⚠ CAUTION

- The 1.5mm cut depth limit setting is important to avoid cutting into the painted sheet metal under the bed cap.
- Take extra precaution not to slip onto the bed caps with the utility knife while cutting the stake pocket holes.

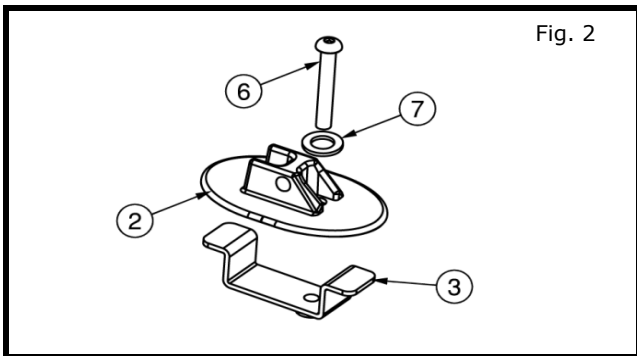

- 2) Repeat step 1 for all four stake pocket locations.

- 3) Assemble base to mounting bracket using M8 x 65mm bolt as shown (See Fig. 2). Only turn mounting bracket on a few threads (See Fig. 3).

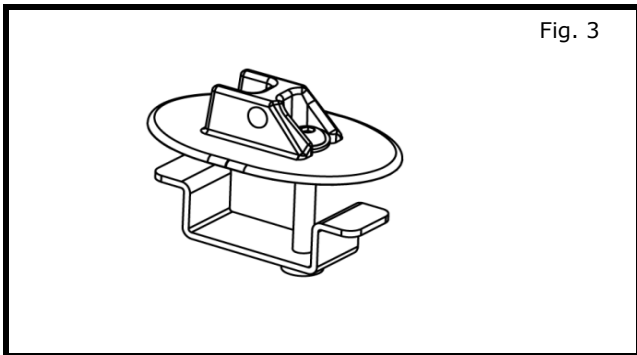

- 4) Repeat step 3 for all bases.

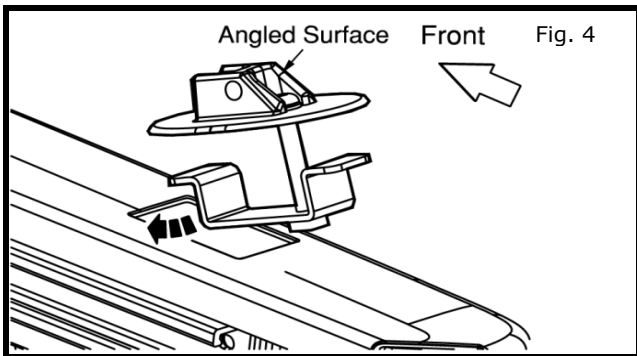

- 5) Rotate assembled base into rear stake pocket hole. Rear locations must be oriented so angled surface is facing rear of vehicle (See Fig. 4). Hand tighten only.

INSTALLATION PROCEDURE: (continue)

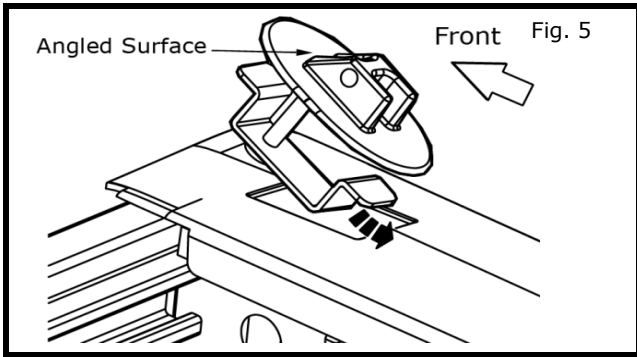

- 6) Rotate assembled base into front stake pocket hole. Front locations must be oriented so angled surface is facing front of vehicle (See Fig 5). While inserting bracket, twist slightly towards outside of vehicle. Hand tighten only.

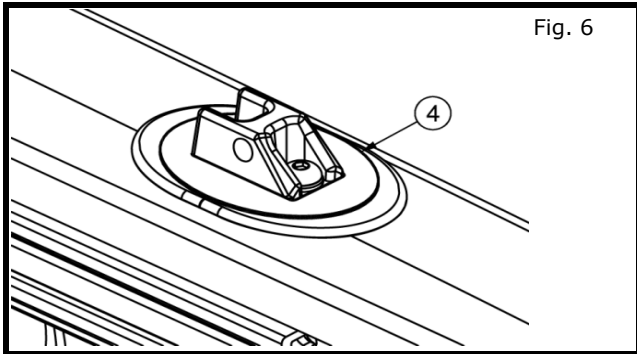

- 7) Place gasket on bases as shown (See Fig 6). Repeat for all locations.

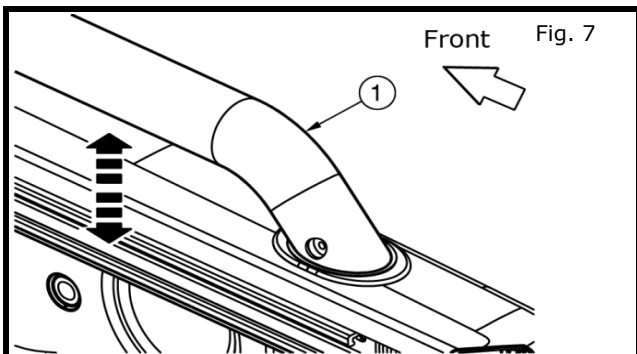

- 8) Place side rail tube over bases with holes facing towards center of vehicle. Push down until bases are properly located. Lift side rail tube straight up and off bases (See Fig. 7).

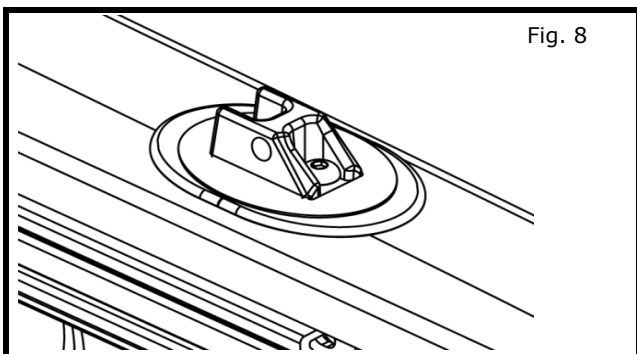

- 9) Place side rail tube over the bases holes facing towards the center of vehicle. Align both bases so they cover stake pockets. Push down on the tube and insert the short M8 bolt. Hand start a few turns only. Slide the rail into position ensuring that stake pockets are covered. Remove short M8 bolt and carefully lift side rail tube straight up and off bases. Pay careful attention not to move bases.

- 10) Using a 5mm allen head drive, tighten all bases to vehicle. Tighten to 16 ft·lbs.

INSTALLATION PROCEDURE: (continue)

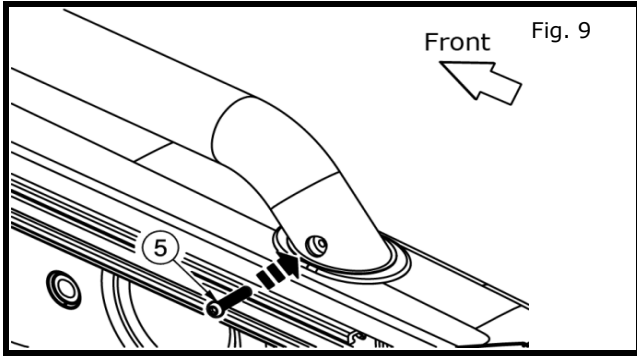

- 11) Assemble side rail tube to base using 8mm x 45mm long bolt. Tighten all bolts using 5mm allen head drive. Torque to 16 ft·lbs. Repeat for all corners.