



# GENUINE PARTS

## INSTALLATION INSTRUCTIONS

<b>DESCRIPTION:</b>	WiFi
<b>APPLICATION:</b>	Rogue
<b>PART NUMBER(S) REQUIRED FOR INSTALLATION:</b>	T99Q8 4RA0A (Wifi kit) 999Q9-AY001 (Accessory Service Connector) - <b>Not Included in T99Q8 4RA0A (Wifi kit)</b>
<b>KIT CONTENTS:</b>	

Item	Qty.	Part Description	Service Part Number
A	1	WiFi TCU Module	T98Q8 4RA0A
B	1	Wire Harness	T98Q8 4RA1A
C	1	Activation Card	
D	8	10" Cable Ties	
E	8	Foam Tape 1" x 3.5"	
F	3	Posi-Taps	999M1 VT000
G	2	Alcohol wipe	
H	1	Two Sided Foam Tape	
I	5	Pet clear Tape 1" x 4"	
J	1	II Replacement Template	
K	1	Glove Box Brochure	

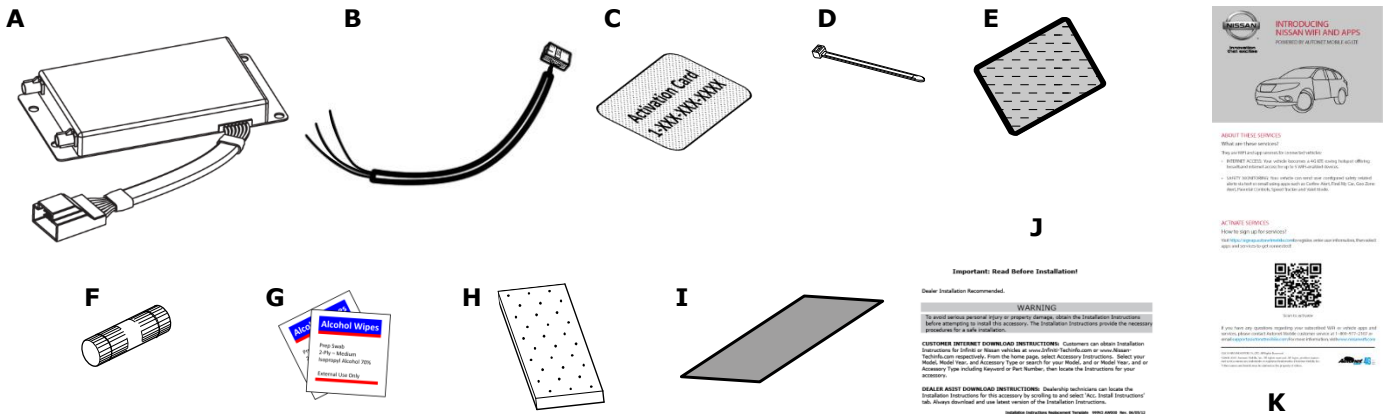

### 999Q9 AY000 (ACCESSORY SERVICE CONNECTOR) - SERVICE PART

Item	Qty.	Part Description	Service Part Number
AA	1	Accessory Service Connector ( <b>NOT INCLUDED IN KIT</b> )	999Q9-AY001



**Note:** 1 or 2 ASC (Accessory Service Connector) may already be installed in the vehicle.

#### TOOLS REQUIRED:

- #2 Phillips Screwdriver
- Nylon Trim Tool
- Wire Cutter
- Flashlight
- 10mm Socket
- Ratchet

**Vehicle Preparation:**

**⚠ CAUTION**

• Always confirm the ignition is in the "OFF" position before changing the switch condition.

- 1) Apply parking brake
- 2) Confirm vehicle is not in the default shipping state or "Inventory position" as shown below. Failure to confirm vehicle has been removed from this state will result in loss of normal vehicle operation.
- 3) Locate Extended Storage Switch in cabin fuse block. Confirm it is in the "Customer" position. See below for reference.
  - a) To remove transit mode (Fuse Block):
    1. Remove fuse cover lid.
    2. Push down shorting pin.
    3. Ign On 2 times without starting the vehicle.
  - b) To remove transit mode (BCM):
    1. Confirm ignition switch is in "OFF" position.
    2. Simultaneously push the signal and wiper switch fully down for two (2) seconds.

**NOTE:** While in BCM Transit Mode, turn signal indicators will remain illuminated for one minute.

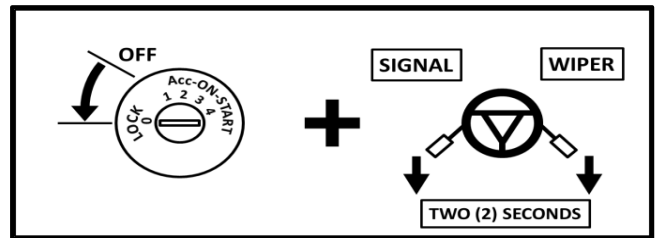
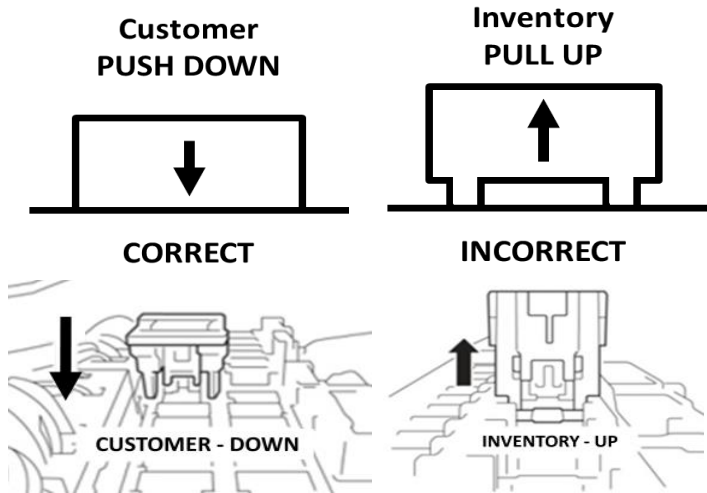

- c) To return to transit mode for storage:
  1. Ign Off.
  2. Remove fuse cover lid.
  3. Pull up shorting pin.
  4. Assemble fuse cover lid.
  5. Ign On 2 times without turn the vehicle on.
  6. Confirm transit mode condition on meter

**NOTE:** Typical vehicle condition shown above. Switch is easily identifiable by the permanent, push-pull fuse holder. Actual position on the fuse block may vary, vehicle to vehicle.

Condition	Switch Position	Note
Vehicle is delivered to the dealer	Inventory Condition	
Technician performs PDI	Customer Delivery	Return to Inventory position after PDI.
Customer test drives the vehicle	Customer Delivery	Return to Inventory position after test drive.
Vehicle is being stored at the dealer	Inventory Condition	
Vehicle is delivered to customer	Customer Delivery	

**NOTE:** The Extended Storage Switch is only an aid to improve battery life during vehicle storage at the dealer. If the Extended Storage Switch fuse ever needs service after vehicle delivery, discard the Extended Storage Switch and install the correct fuse in its place.

- 4) Turn ignition switch to "ON" position
- 5) Record the customer radio presets and other presets as required.

Preset	1	2	3	4	5	6		

- 6) Put shift lever in "P" position for A/T and CVT or "1st" for M/T
- 7) Turn ignition switch to "OFF" position
- 8) Use seat and floor protection.

## INSTALLATION PROCEDURE: PRE-INSTALLATION CAUTIONS / NOTES

### **⚠ CAUTION**

- Allow 3 min after key off and doors closed for vehicle to time out. Allow an additional 3 min after negative terminal dis-connect before separating any electrical connectors.

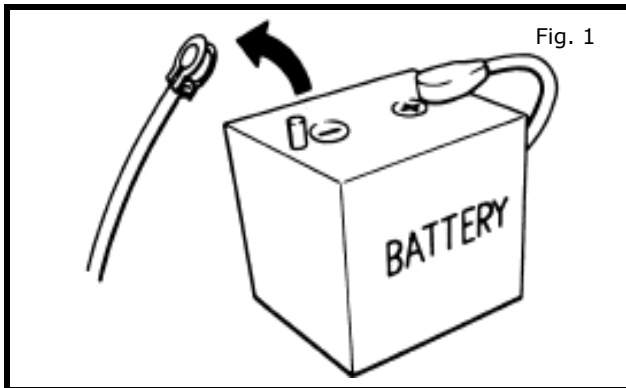

- 7) Disconnect the negative battery terminal as shown in Fig. 1.
- 8) Use seat and floor protection.
- 9) This part is to be installed at surface temperature of 65-100 deg.F.

### **⚠ CAUTION**

- Take care not to scratch or damage any component during the removal or re-installation process.
- Trim pieces found to have witness marks or broken clips are not to be reinstalled.
- Additional items in cargo area may need to be removed.
- Always remove vehicle parts in the sequence they are shown, improper procedure can damage parts.
- Store removed parts in a safe and protected manner.

#### INSTALLATION OVERVIEW:

##### 1.) SYSTEM

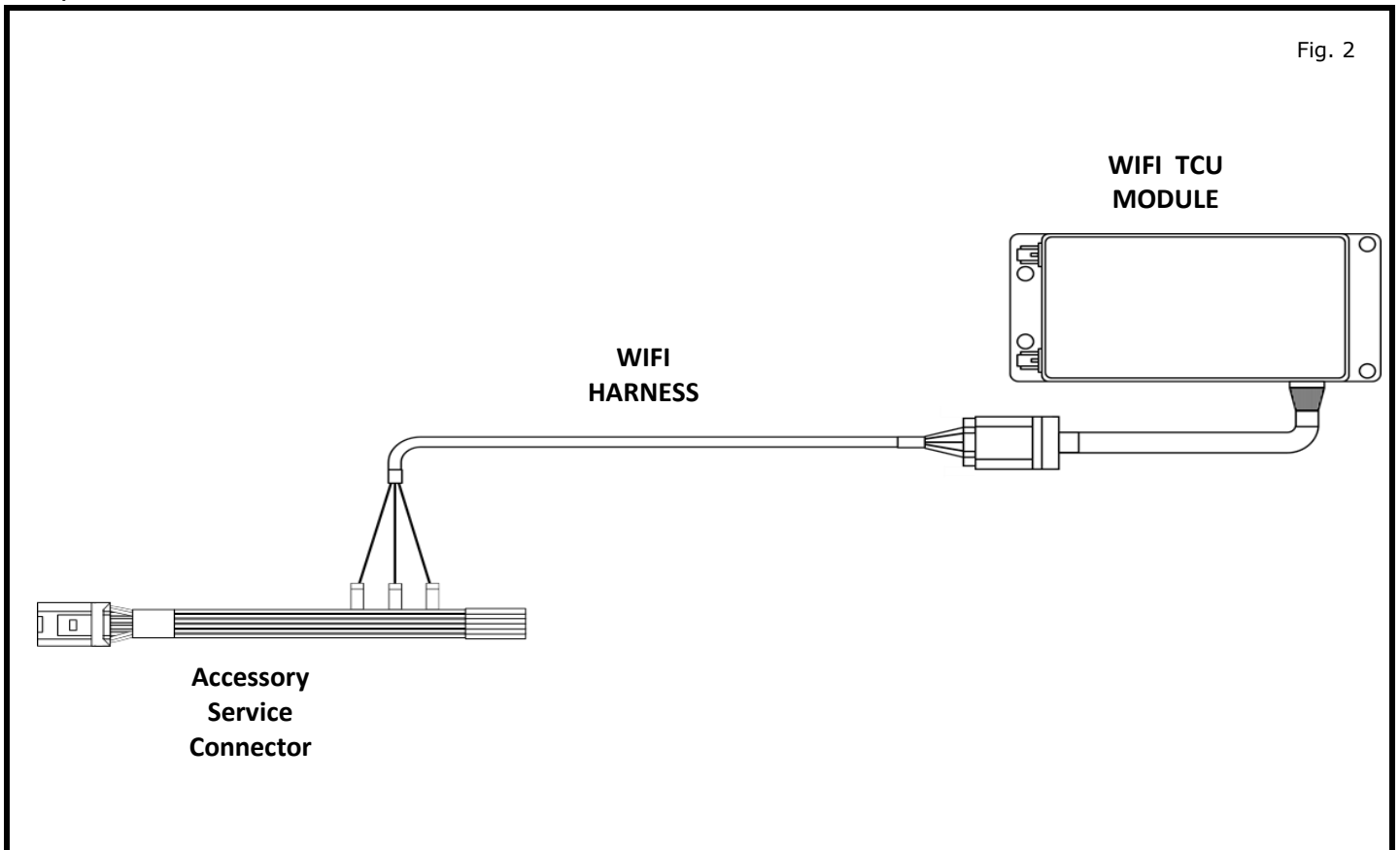

**INSTALLATION OVERVIEW:**

2.) VEHICLE

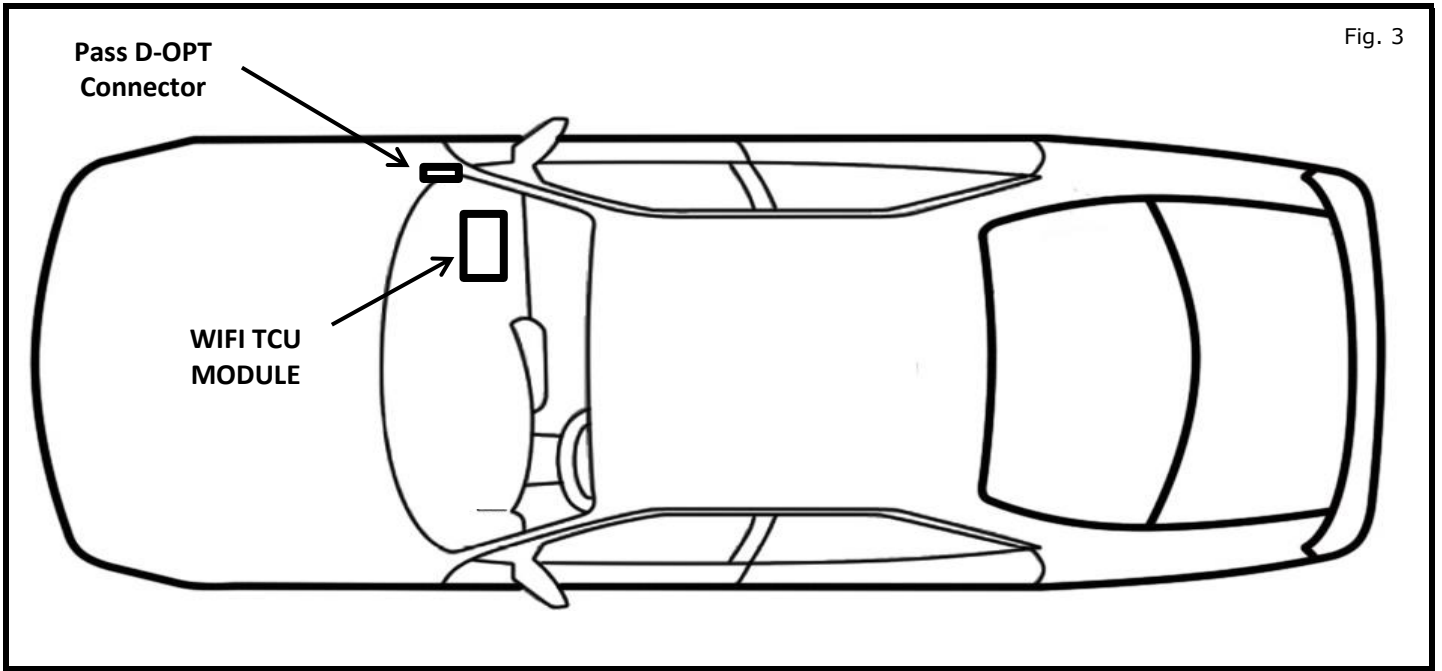

**⚠ CAUTION**

- Any description of vehicle wiring color is for reference only.
- Always refer to vehicle wiring diagram for details.

3) Routing

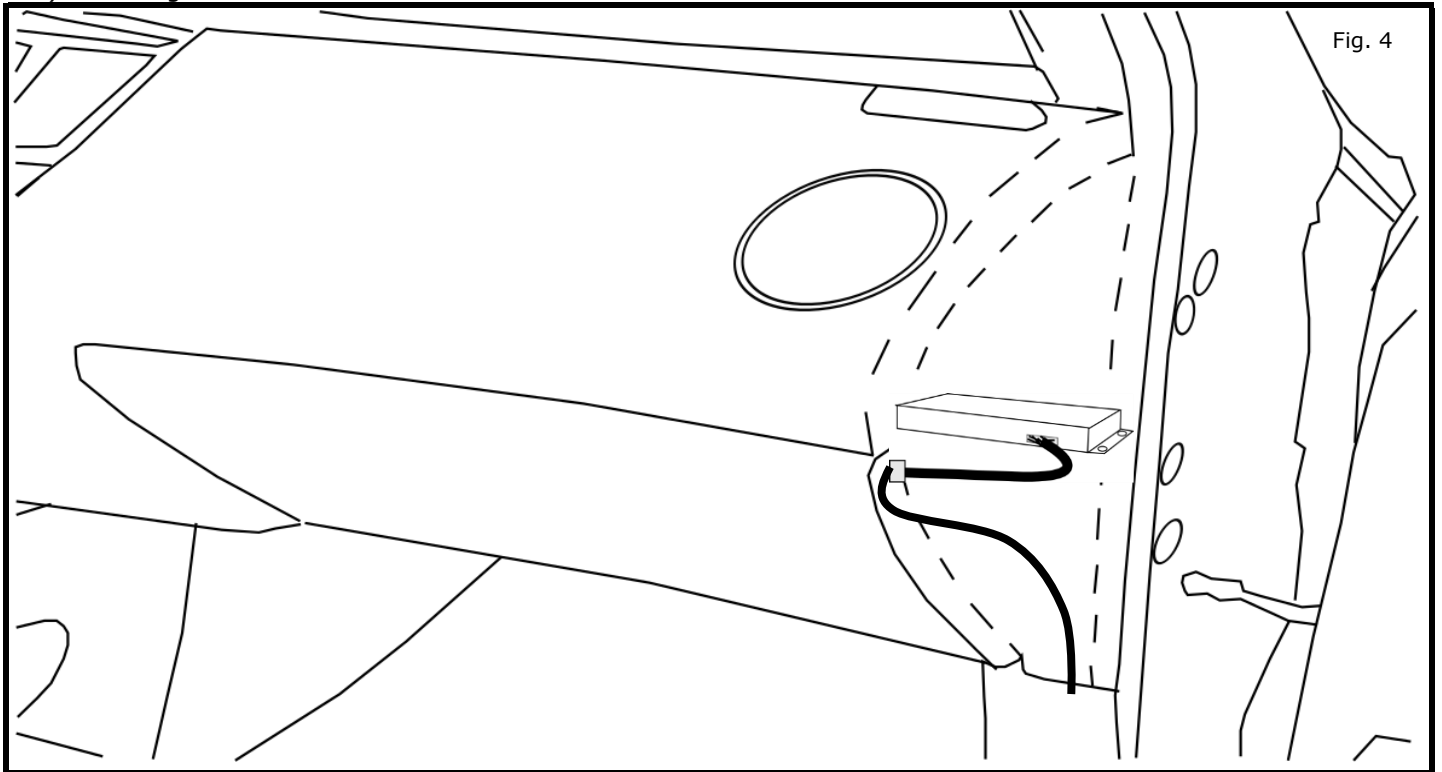

**INSTALLATION PROCEDURE:**

**VEHICLE PARTS REMOVAL**

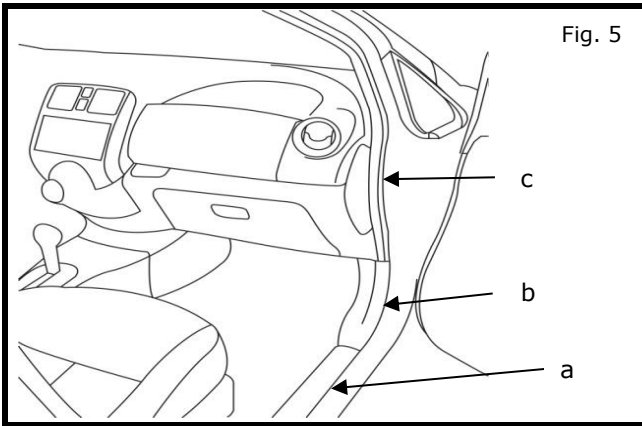

- 1) Removing items as follows:
  - a) Passenger Kick Plate.
  - b) Passenger Kick Panel.
  - c) Passenger side dash mask

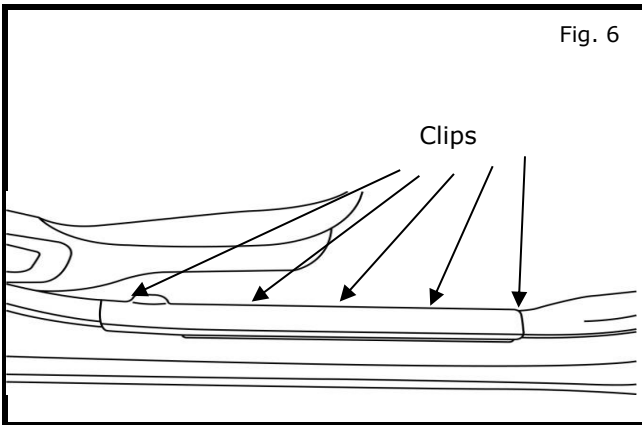

- 2) Removing passenger kick plate.

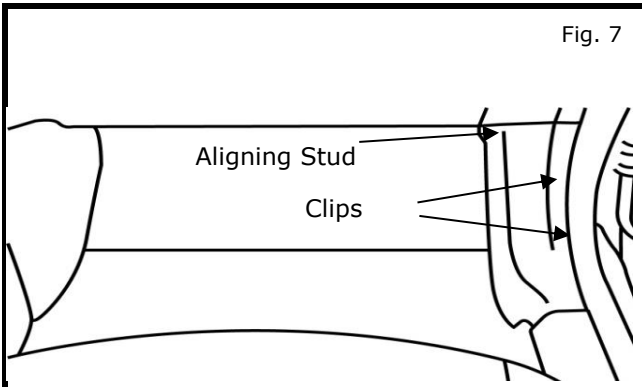

- 3) Removing passenger kick panel.

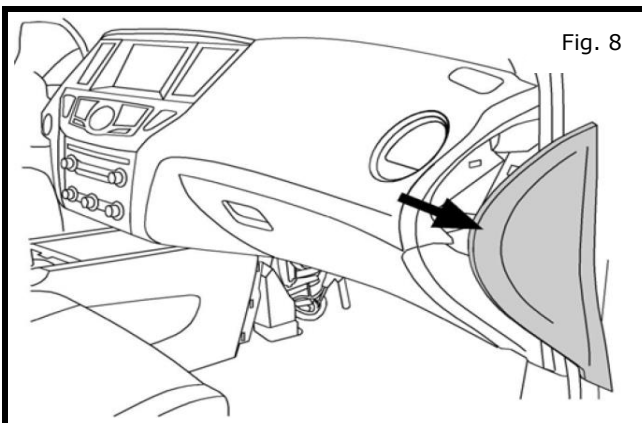

- 4) Removing dash mask.
  - a) Carefully pry off passenger side dash mask as shown using a nylon trim tool.

**INSTALLATION PROCEDURE:**

**VEHICLE PARTS REMOVAL**

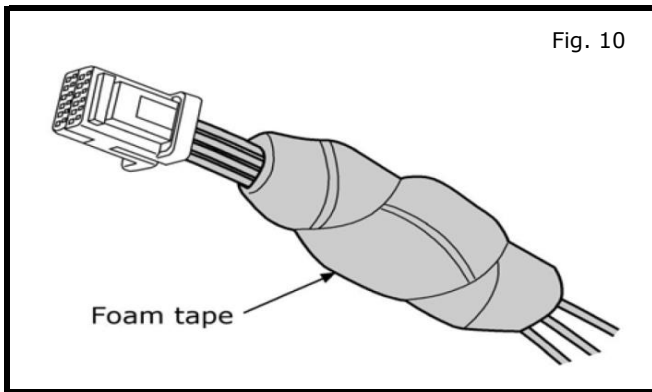
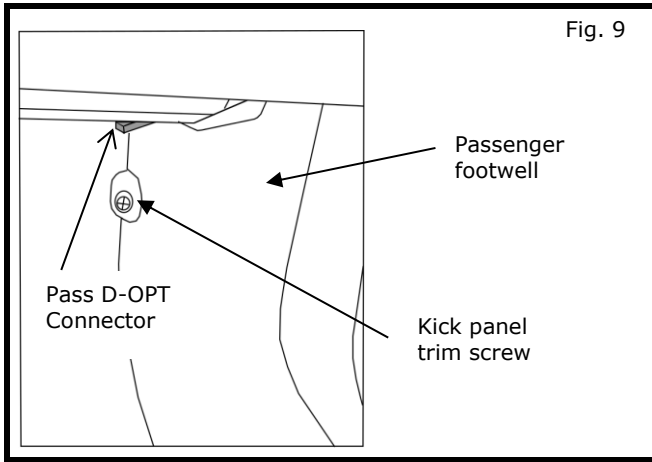

999Q9 AY001

Pin	Label	Color
1	IGN	WHITE
2	BAT	RED
3	TL LMP	PURPLE
4	RM LMP	YELLOW
5	BATSVR	PINK
6	FR_DR_SW_RH	GREEN
7	FR_DR_SW_LH	LT GREEN
8	THRU SIGNAL 1	GREY
9	RR_DR_RH	BLUE
10	RR_DR_LH	LT BLUE
11	ACC	ORANGE
12	GND	BLACK

Fig. 11

Pin location is referenced looking from the harness side of connector.

1	2	3	4	5	6
7	8	9	10	11	12

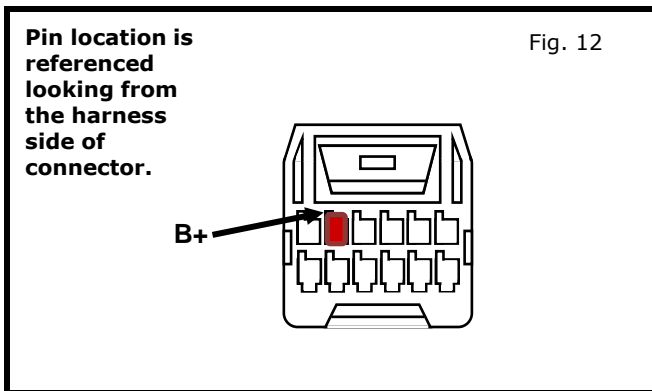

- 5) Locating Passenger D-OPT Connector
  - a) Locate passenger side D-OPT Connector on right side of the footwell as shown in Fig. 9. Cut Pass D-OPT connector cable tie to access the connector.

- b) **Positap after step 28a). Go to step 22 now.**

**Note:**

**1.) If there is already an Accessory Service Connector in passenger side read step 6, if not proceed to step 7.**

**2.) If there is not an Accessory Service Connector in passenger side remove dummy plug in connector.**

- 6) Locating Accessory Service Connector
  - a) If there is already an Accessory Service Connector in passenger side remove it before continuing.

- b) Remove any foam tape present before adding any positaps as shown in Fig. 10.

**Note:** □

**If there is not an Accessory Service Connector present in passenger side connector order from service dept.**

- 7) Accessory Service Connector Reference
  - a) Accessory Service Connector pin out is shown in Fig. 11.

**Note:**

**1.) For direction on how to posi-tap refer to steps 11 - 21.**

**2.) For additional circuit information refer to the mech drawing at the end of the installation instructions.**

- 8) Positap B+
  - a) Tap **Red** wire on WiFi TCU Module harness to Red (B+) wire on Accessory Service Connector as shown in Fig. 12.

## INSTALLATION PROCEDURE: POSI-TAP

Pin location is referenced looking from the harness side of connector.

Fig. 13

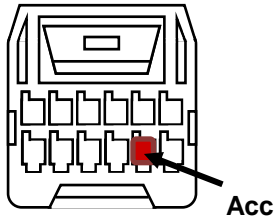

Pin location is referenced looking from the harness side of connector.

Fig. 14

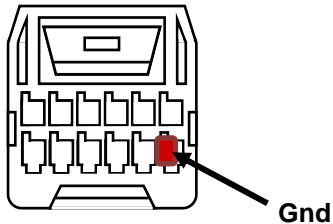

- 9) Positap ACC
  - a) Tap the **White** wire on the WiFi TCU Module harness to the Orange (Acc) wire on the Accessory Service Connector as shown in Fig. 13.

- 10) Positap GND
  - a) Tap **Black** wire on WiFi TCU Module harness to Black (Gnd) wire on Accessory Service Connector as shown in Fig. 14.

**NOTE:** Figures are not to scale.

6.35mm

Fig. 15

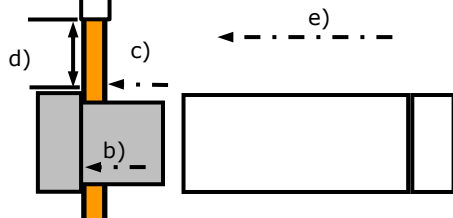

Accessory Service Connector

- 11) Posi-tapping an Accessory service wire (Fig. 15)
  - a) Identify and confirm correct wire in Accessory Service Connector to be tapped.
  - b) Remove cap (slot side) from tap body.
  - c) Slide cap around single accessory wire.
  - d) Position cap  $\geq 6.35\text{mm}(0.25\text{in})$  away from the heat shrink end of Accessory Service Connector (measurement for first posi-tap installed on the circuit).
  - e) Tighten tap **TIGHT** with finger pressure.
  - f) Tighten by another quarter turn.

Fig. 16

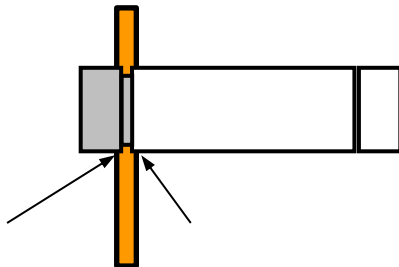

- i. Straight and evenly spaced all the way around
- ii. **Tighten** and **minimize** gap (wire jacket should

- 12) Inspecting tap for correct installation (Fig. 16).
  - a) Pull on wire lightly to ensure connection.
  - b) Inspect tap to ensure correct installation.
  - c) Test signal to ensure that it is working properly.

**NOTE:**

**Avoid putting pressure on the vehicle wire and tap for the remainder of the installation.**

## INSTALLATION PROCEDURE: POSI-TAP

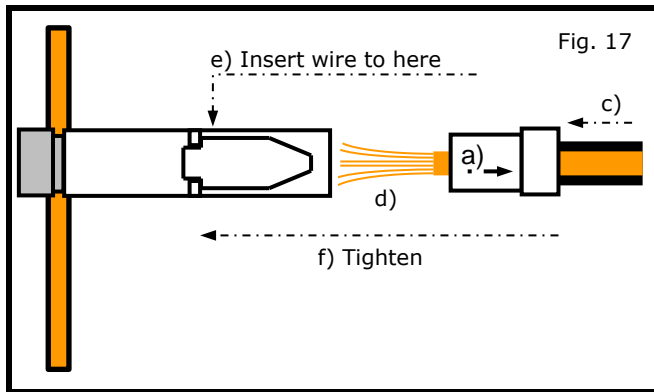

- 13) Tap accessory wire (Fig. 17).
  - a) Remove tap (non-pierce) side from tap.
  - b) Remove the protective stub from wire.
  - c) Insert wire through non-pierce side opening.
  - d) Spread the individual strands into fan shape.
  - e) Insert wire into tap body and ensure that it is all the way in.
  - f) Tighten tap **TIGHT** with finger pressure.
  - g) Tighten by another quarter turn.

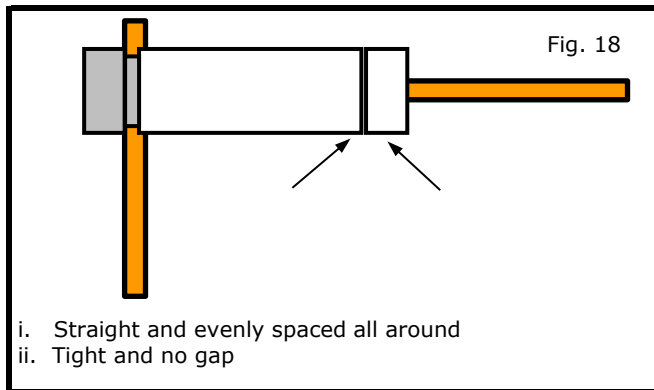

- 14) Confirm tapped accessory wire.
  - a) Pull on wire lightly to ensure connection.
  - b) Inspect tap to ensure correct installation as shown in Fig. 18.

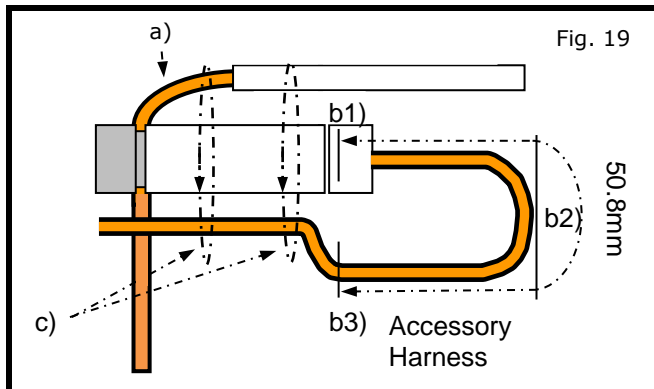

- 15) Forming strain relief loop - required (Fig. 19).
  - a) Gently bend end of pierced wire (where it exits cap) down towards body of posi-tap.
  - b) On tapped wire of non-pierce side; starting at point b1), measure 50.8mm(2in) to point b3). Make first bend of loop b2), half distance measured 25.4mm(1in), and up toward body of posi-tap, make second bend of loop b3).
  - c) Secure pierced wire on heat shrink side and tapped wire on non-pierce side to body of tap with electrical tape ( $\geq 2$  revolutions).

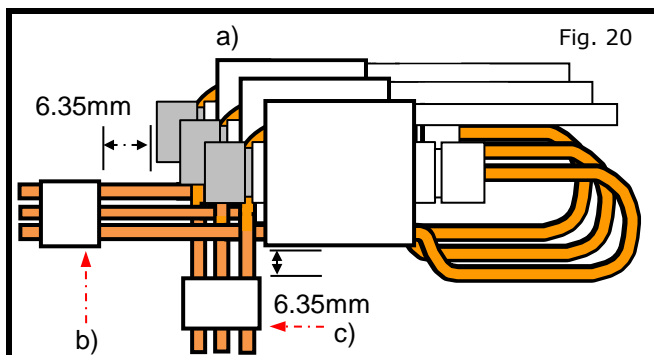

- 16) Securing multiple accessory taps (Fig. 20).
  - a) Tapped accessories (wires already secured to tap bodies) are stacked slightly staggered on top of each other as shown in Fig a).
  - b) Tapped wires on non-pierce side of all posi-taps are secured to each other with electrical tape ( $\geq 2$  revolutions) at a distance of  $\geq 6.35\text{mm}$ (0.25in) as shown in Fig b).
  - c) Pierced wires of first and subsequent posi-taps are secured to each other with electrical tape ( $\geq 2$  revolutions) at a distance of  $\geq 6.35\text{mm}$ (0.25in) as shown in Fig c).



## INSTALLATION PROCEDURE: POSI-TAP

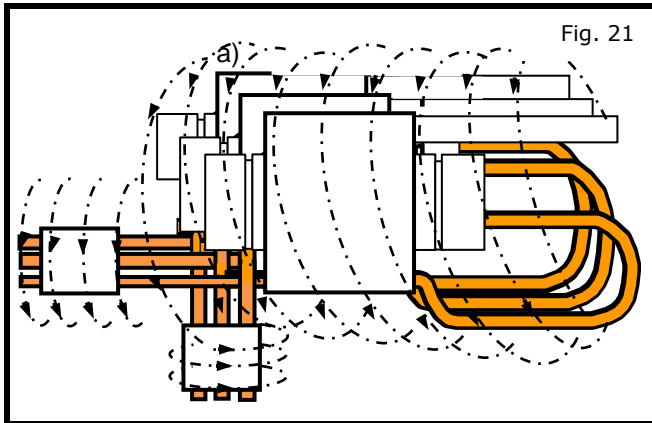

- 17) Pre- foam protective wrap
- Starting at heat shrink; firmly wrap posi-tap bundle with electrical tape or non-adhesive wire harness tape, making sure to overlap the previous revolution as shown in Fig. 21.

**Note:**

**If using a non adhesive tape to wrap the bundle, secure at both ends with  $\geq 2$  revolutions adhesive electrical tape.**

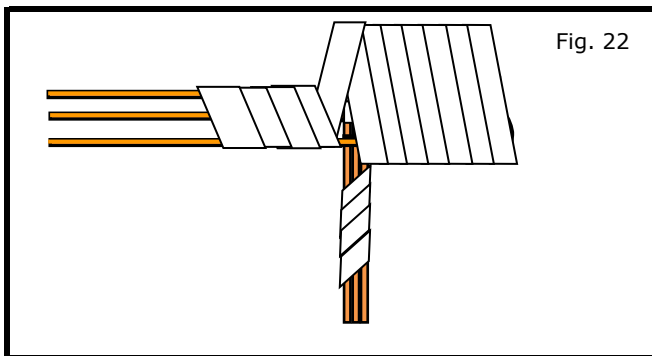

- 18) Finished protective wrap
- Make sure finished wrap looks similar to Fig. 22.

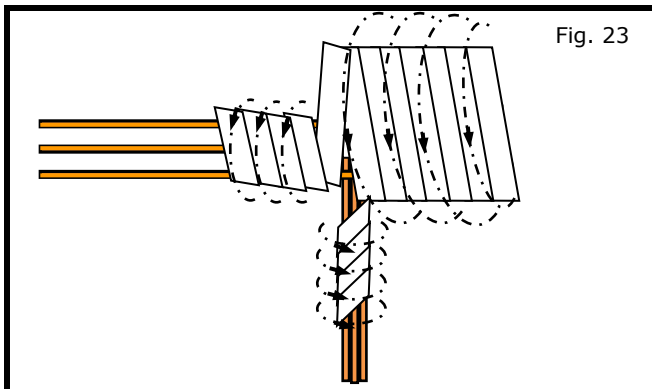

- 19) Foam wrap for posi-tap bundle (foam strips)
- Wrap posi-tap bundle with foam tape, following a pattern similar to the electrical tape, making the best use of foam strips provided as shown in Fig. 23.

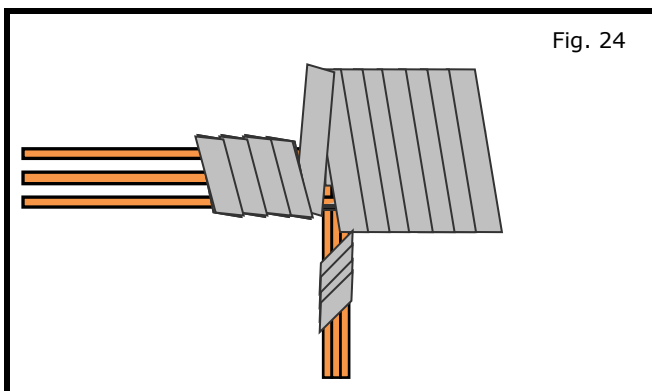

- 20) Finished foam wrap for bundle (strips-top view)
- Make sure finished wrap looks similar to Fig. 24.

## INSTALLATION PROCEDURE: POSI-TAP

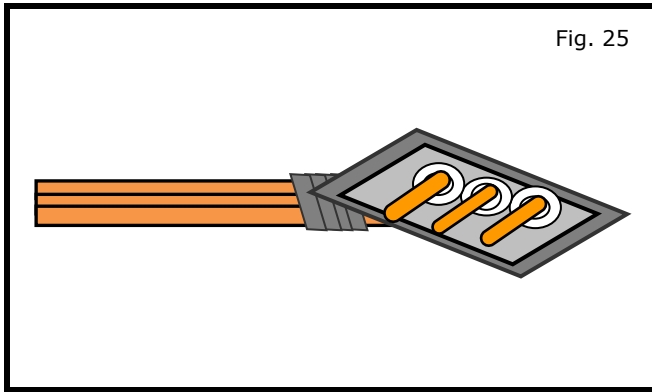

- 21) Finished foam wrap for bundle (strips-side view)
- Make sure the finished wrap looks similar to what is shown in Fig. 25.

### CAUTION

**This Accessory Service Connector is for use only with Genuine Nissan (or Infiniti) or Nissan (or Infiniti) approved accessories. Use of this connector with non Genuine Nissan (or Infiniti) or Nissan (or Infiniti) approved accessories or failure to follow the installation instructions for the connector contained in this package may result in damage to the accessory and/or your vehicle. Nissan (or Infiniti) is not liable for loss or damage due to improper installation or the installation of non Genuine or non approved accessories.**

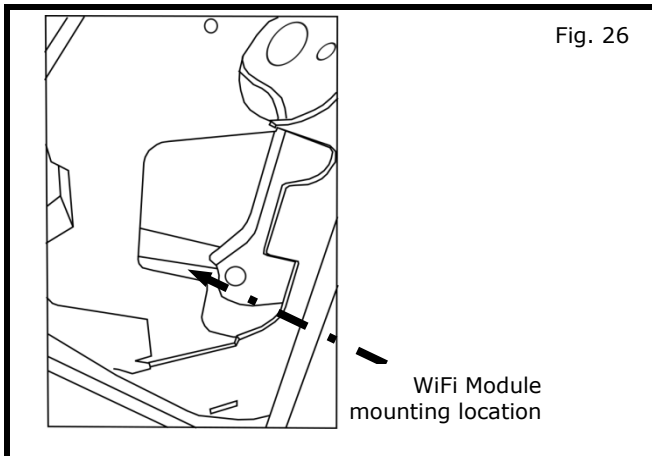

- 22) Prepping surface for mounting WiFi module.
- Clean glove box installation surface and WiFi base plate with an alcohol wipe.

**WiFi mounting location is inside side dash mask area.**

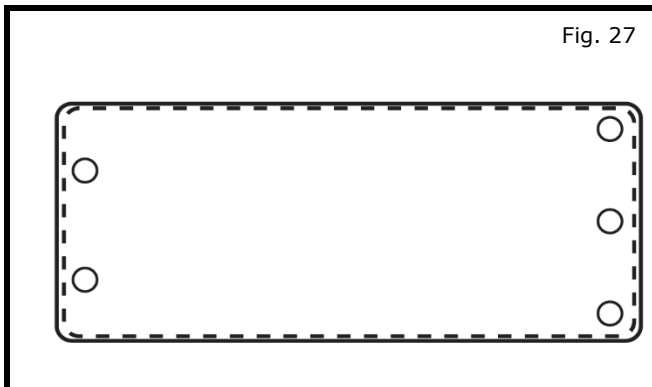

## INSTALLATION PROCEDURE: WIFI MODULE

Fig. 28

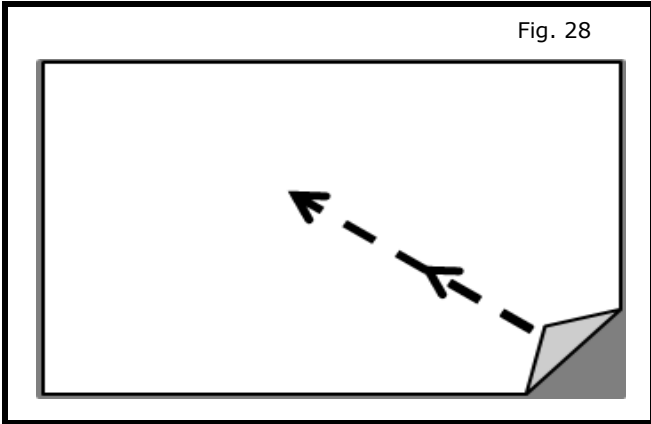

- 23) Module Installation
- Peel tape liner off of adhesive square as shown in Fig. 28.

Fig. 29

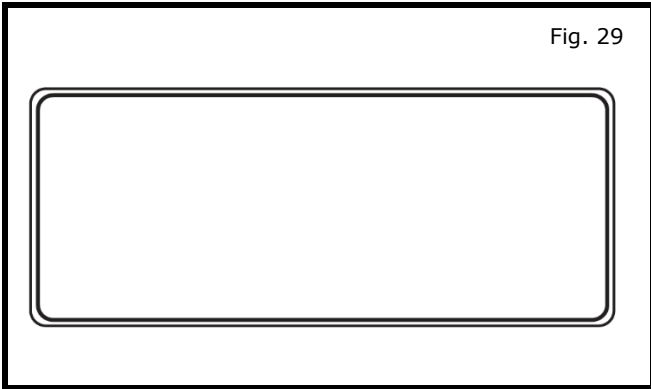

- 24) Module Installation
- Apply double sided tape to base plate of WiFi module as shown in Fig. 29.

Fig. 30

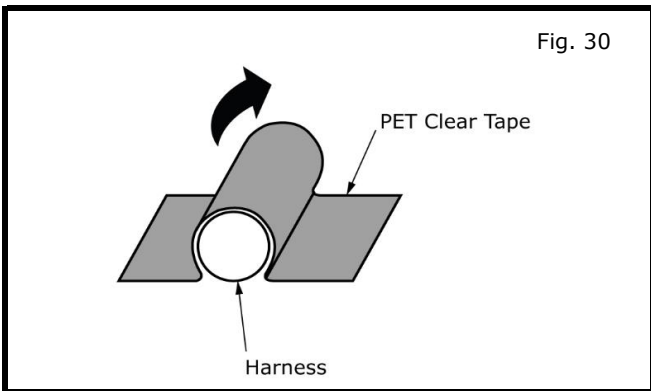

**NOTE:**  
When taping PET clear tape to glove box, ensure tape is wrapped up and over harness as shown in Fig. 30.

Fig. 31

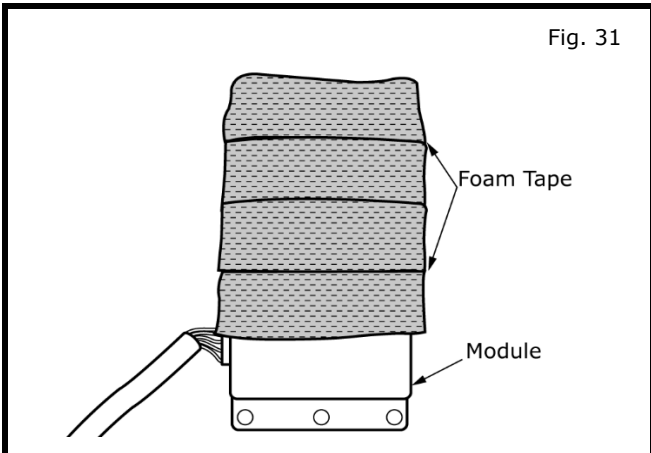

- 25) Module Installation
- Wrap module on top with foam tape as shown.

## INSTALLATION PROCEDURE: WIFI MODULE

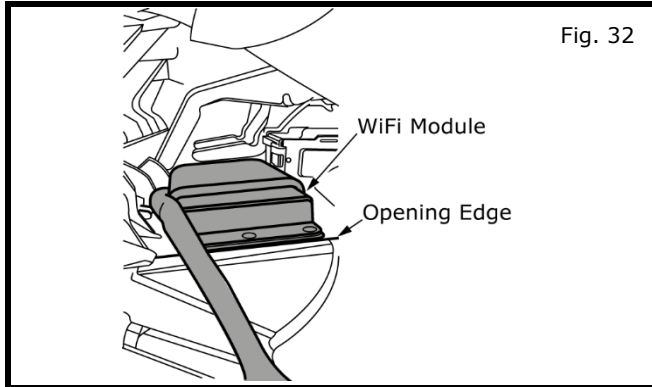

- 26) Module Installation  
Place WiFi module inside opening, behind dash mask; and line with edge of opening. **Line up before taking off tape liner.**

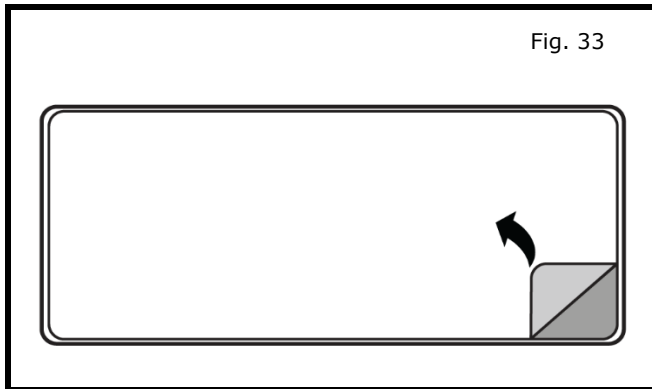

- 27) Module Installation
- Peel tape liner from foam pad on module as shown in Fig. 33.
  - Carefully place module with paper liner off in same position as in step 26. Press WiFi module to opening with 15lbs min. pressure.

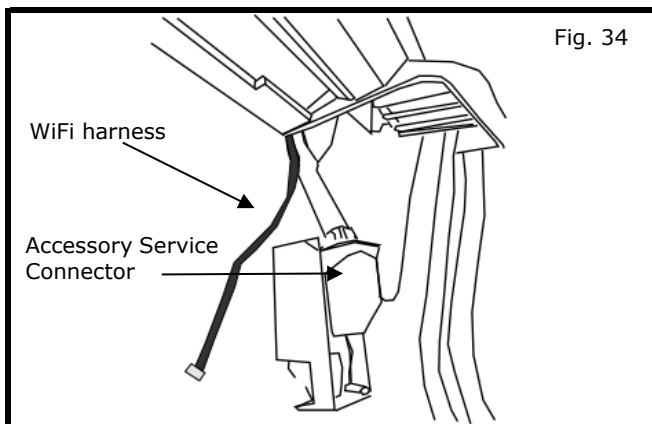

- 28) Module Installation
- Connect WiFi harness to WiFi module. Route harness down inside opening in side mask area to Pass D-OPT Connector located in passenger kick well area.
  - Positap per instructions steps 6 - 21. If no other Accessory Service Connector is present, may positap first and feed ASC down side mask area.  
Foam wrap positaps on ASC.

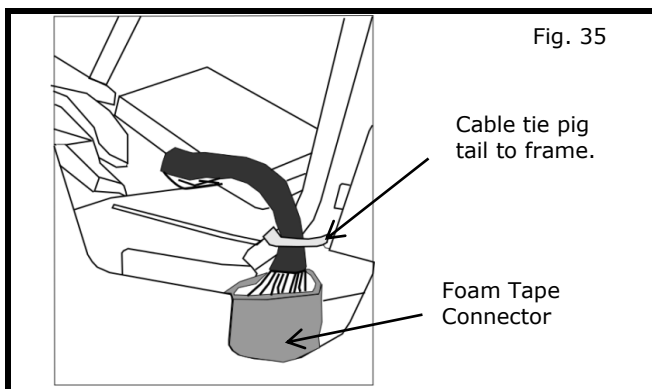

- 29) Module Installation  
Foam wrap pig tail male connector to prevent rattling. Cable tie pig tail connector to frame as shown.  
Push connector to inside.

## INSTALLATION PROCEDURE: WIFI MODULE

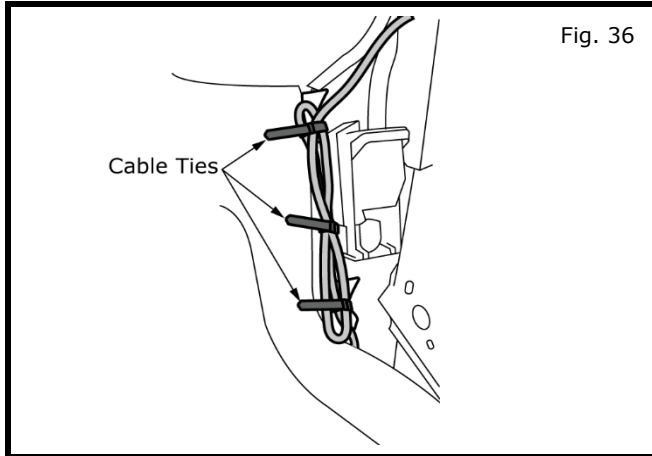

- 30) Routing harness
- a) Place Pass D-OPT connector in original position prior to cutting cable tie. Cable tie positaps and extra harness to vehicle wire harness with 3 cable ties.
  - b) Re-install all parts that were removed. Once completed perform the final check on page 14 and the WiFi test on pages 15 and 16.

## FINAL INSPECTION:

### CAUTION

**Use caution when re-installing interior components to avoid damage, scratches, or breaking of mounting clips. Refer to the vehicle service manual for more information.**

- Inspect the installation area for any debris.
- Make sure all trim clips are in their retainers and gently press the trim panels into place.
- Verify re-installed trim parts for proper flush fit (no gap, no waviness, etc.).
- Verify all clips are fully engaged and locked.
- Verify re-installed trim parts are free from cracks, scratches or stress marks.
- Verify vehicle headliner, seat, steering wheel, center console, floor carpets, etc. are not soiled.
- Verify interior and exterior is not damaged.
- Connect the battery negative terminal and tighten the nut to 5.4 N-m (47.8 lb-in).
- Turn ignition switch to "OFF". Wait 10 seconds, then switch to "ON".
- Turn ignition switch to "ON" and confirm proper operation of vehicle systems and verify:
- Re-program radio presets and other vehicle settings to the recorded settings.
  - Confirm proper audio function (AM, FM, SAT, CD and AUX).
  - That there are no new Diagnostic Trouble Codes.
  - Verify all windows and sunroof (if equipped), one touch operation and perform the reset procedure if necessary. Refer to the vehicle service manual for more details.
  - Power Back Door (If equipped). - Turn on the car, push and note if trunk opens.
  - Tail Lamp - Turn on headlamps; open glove box and note whether light goes on.
  - Start vehicle. Note whether vehicle starts.
- Front Sonar Module Connector - Turn on vehicle, put vehicle in 'Drive'. Move slowly towards a large object in front of the vehicle. Note whether alarm sounds.
- Rear Sonar Module Connector - Turn on vehicle, put vehicle in 'Reverse'. Move slowly towards a large object behind the vehicle. Note whether alarm sounds.
- Place the Owner Manual, Quick Reference Guide, and/or other Manual in the glove box.

## FINAL INSPECTION: CHECK OUT

- Turn your car to the ACC position to power up the WiFi module. Wait 3 minutes.
- Open your wireless network list and connect to "Autonet-XXXX" (The last 4 digits will be the last 4 digits of the WiFi serial number).
- Open your browser the following screen appears.

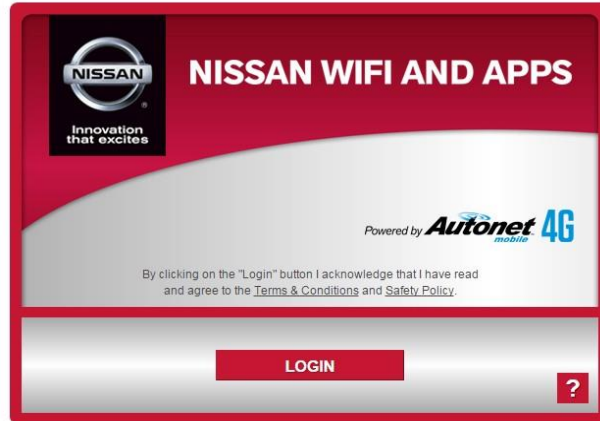

Autonet assumes no responsibility for the configurations, security, or data files on your wireless device resulting from connection to Autonet's network. Anti-virus, privacy, and security protection is the responsibility of the user.

Autonet Mobile recommends that the driver of this vehicle should not attempt to use this system while driving the vehicle.

Do not operate any function that takes your attention away from safely driving your vehicle. Any function that requires prolonged attention should be performed after coming to a complete stop. Always stop the vehicle in a safe location before performing these functions. Failure to do so may result in an accident.

Copyright © 2008 - 2015 Autonet Mobile, Inc. All Rights Reserved.

- Click the LOGIN button. If the following screen appears showing no signal while trying to log in there is insufficient cell tower signal. The vehicle may have to be moved outside for better reception.



If you are unable to see the "Autonet-XXXX" in your wireless network list verify power is present to the WiFi module. If power is present and module still does not appear on the wireless network list call Autonet Mobile at 1-800-977-2107

## FINAL INSPECTION: CHECK OUT



After pressing the 'Login', the following window will open, the WiFi module is now in communication with the cell tower. Installation is complete.

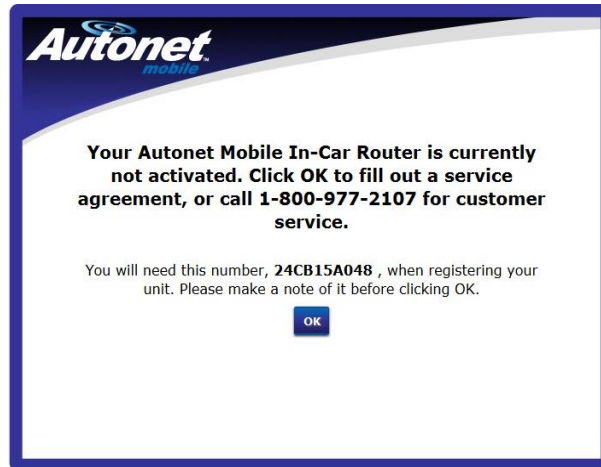

The test verifies data communication via network/telecommunication as indicated by prompting the user to fill out a service agreement.

If the service agreement does not pop up this indicates that the Telecommunications (WiFi/network) failed. Contact Autonet Mobile at 1-800-977-2107



Place the Activation Guide, and glove box brochure in the glove box.

Posi-Tap™ is protected by patent # 5,228,875 5,695,369 5,868,589 6,692,313 Jap 2881414 Aus 708700 Tia 103534 Can 2204826 Mex 200626 Korea 477279 China Z197105562.9 & others pending.



# WIFI

## PASSENGER SIDE

### ACCY\_SER\_CONN

IGN	1
BAT	2
TAIL_LAMP	3
ROOM_LAMP	4
BAT_SAVER	5
FR_DOOR_SW_RH	6
FR_DOOR_SW_LH	7
THRU_SIGNAL_1	8
RR_DOOR_RH	09
RR_DOOR_LH	10
ACC	11
GND	12

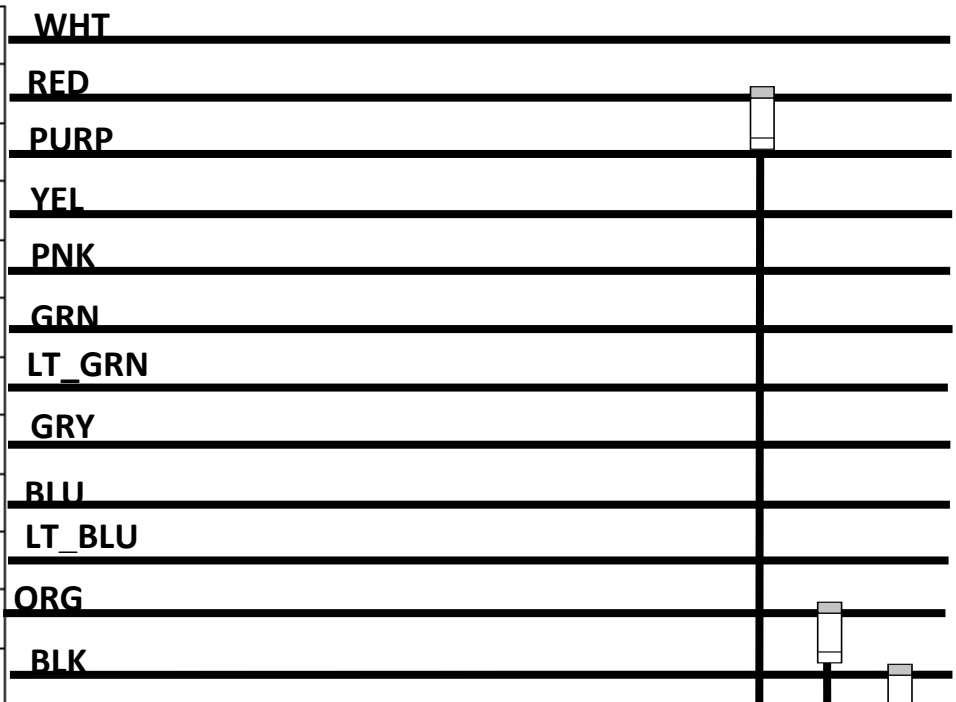

### TH12FW-NH

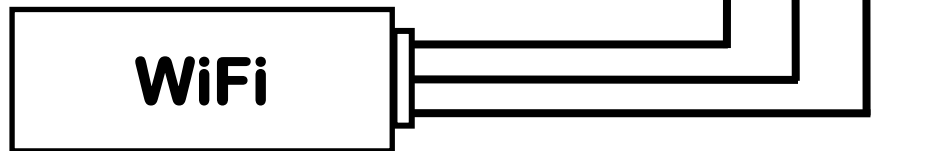
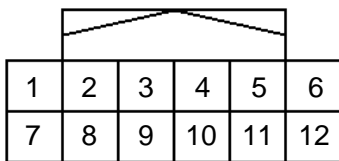

**Note:** Pin location is referenced looking into wire side of connector.

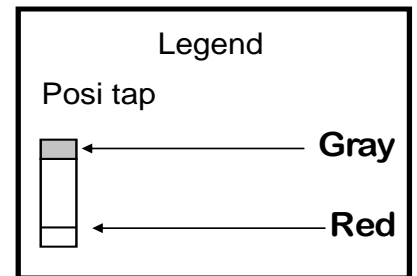

## ⚠ CAUTION

This Accessory Service Connector is for use only with Genuine Nissan (or Infiniti) or Nissan (or Infiniti) approved accessories. Use of this connector with non Genuine Nissan (or Infiniti) or Nissan (or Infiniti) approved accessories or failure to follow the installation instructions for the connector contained in this package may result in damage to the accessory and/or your vehicle. Nissan (or Infiniti) is not liable for loss or damage due to improper installation or the installation of non Genuine or non approved accessories.