



GENUINE PARTS

INSTALLATION INSTRUCTIONS

DESCRIPTION:	Bed Divider - Sliding
APPLICATION:	Nissan Titan
PART NUMBER:	Bed Divider - Sliding (999T7 W4300)
	Installation of this accessory requires installation of additional Part(s): (if not equipped)
	<ul style="list-style-type: none"> • Stop C-Channels End Part Number 93398 7S200 (Quantity 2)

KIT CONTENTS:

Item	Qty.	Part Description
A	1	Bed Divider
B	1	Mounting Bracket
C	1	Mounting Bracket
D	4	Bolt
E	4	Washer
F	2	Anchor Plate
G	2	Knob
H	1	Installation Instructions Replacement Template

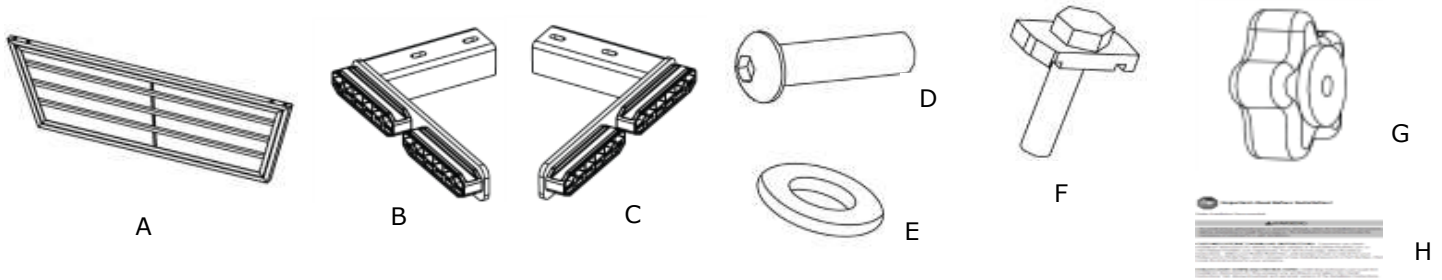

TOOLS REQUIRED:

- Ratchet (3/8" Drive)
- Torque Wrench (Suitable for 44.7Nm or 33ft-lbs)
- 6mm Allen Head Drive
- T30 TORX Wrench (Divider Assembly Bracket)
- Eye Protection
- T40 TORX Wrench (Utilitrack)
- 10mm Socket

PRE-INSTALLATION WARNINGS, CAUTIONS, CRITICAL STEPS, and NOTES:

- Dealer Installation Recommended.
- During the assembly and installation process, be careful not to scratch the surface.

WARNING

- Bolts must be tightened according to the specified torque values.
- This part is not designed as a cargo retention device.
- Do not use bed divider to secure cargo.
- Unrestricted items may cause injury in a crash or sudden brake application. Please consult the owner's manual on how to properly secure cargo.

INSTALLATION PROCEDURE:

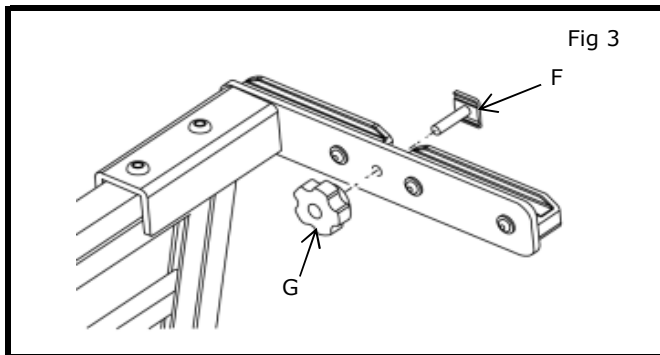
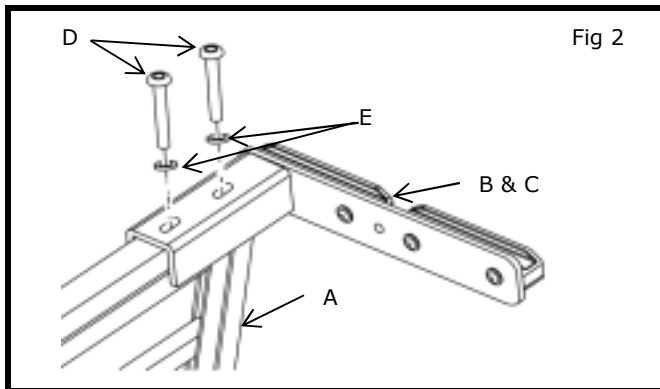
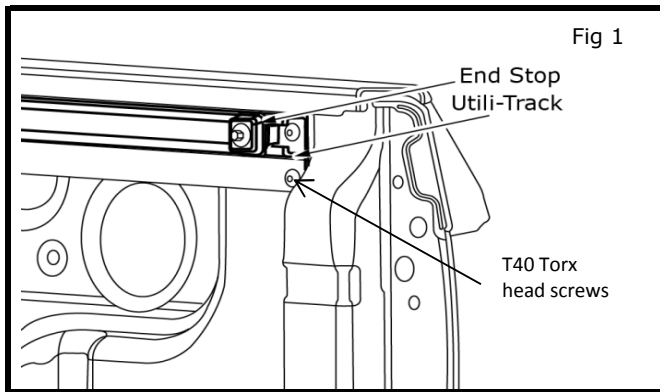

- 1) Remove end stops from utili-track.
- 2) Using a T40 torx head loosen last two torx head screws at end of utilitrack. Do not fully remove screws.

NOTE: Some vehicles may not be equipped with end stops located in vehicle C-Channel. Ends stops MUST be used for this application. Please order from local Nissan dealer.

Nissan Part Number: 93398 7S200 (Quantity 2)

- 3) Loosely assemble mounting brackets (b or c) to divider (a) with bolts (d) and washers (e). Do not tighten.

- 4) Loosely assemble knob (g) and anchor plate (f) to each mounting bracket. Do not tighten.

- 5) Repeat for other side.

INSTALLATION PROCEDURE:

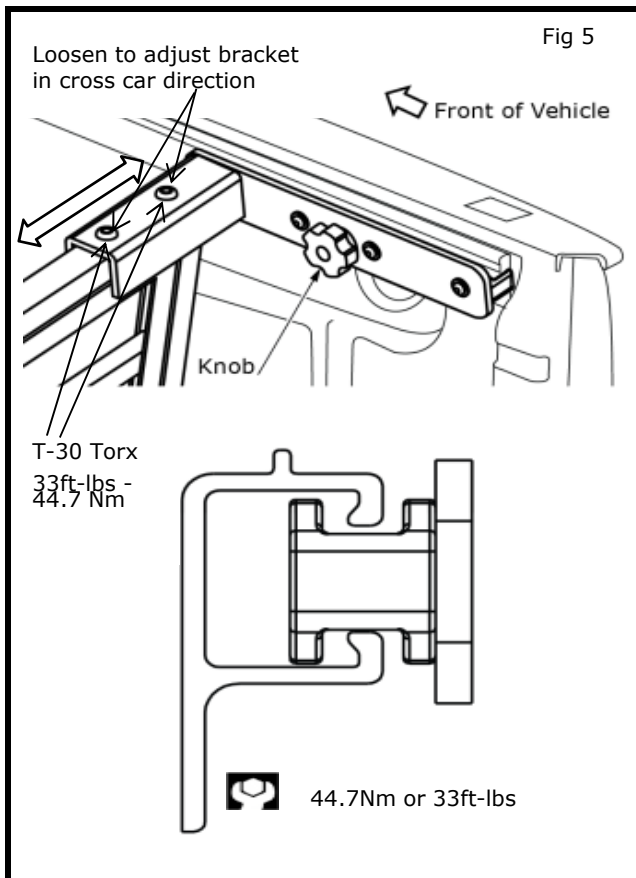
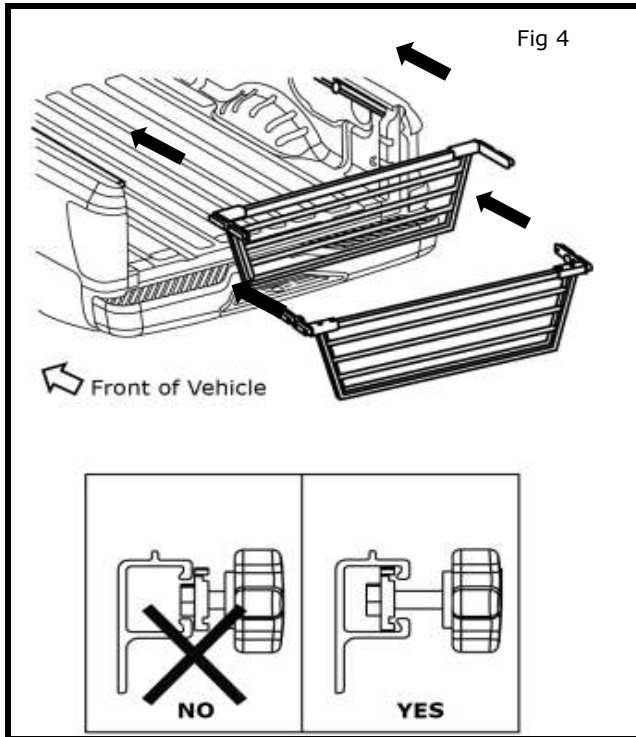

- 6) With tailgate down, slide mounting brackets into utili-track. Be sure anchor plates are inserted into utili-track and not outside of utili-track.

NOTE:

Clean inside of utili-track before proceeding.

- 6) For initial adjustment, align mounting bracket ends with ends of utili-track. Slide mounting brackets out until they are centered as shown in Fig. 5, then tighten. Torque bolts to 44.7Nm or 33ft-lbs.
- 7) Check to ensure divider assembly slides freely from front to rear of bed. If adjustment is required repeat step 6.
- 8) Slide bed divider assembly to desired location and tighten knobs. Turn knobs clockwise and tighten as firmly as possible to secure in position.
- 9) Re-inatall end stop on utili-track and tighten two torx screws loosened in step 2.

INSTALLATION PROCEDURE: FOR C-CHANNEL END STOP (if not equipped)

Fig 1

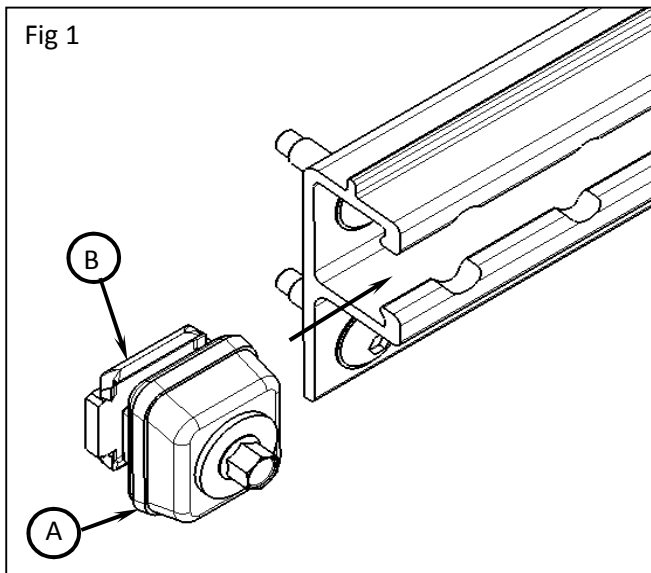

- 10) Slide endstop into channel opening. Channel to be positioned between body (A) and plate (B). See Fig. 1

Fig 2

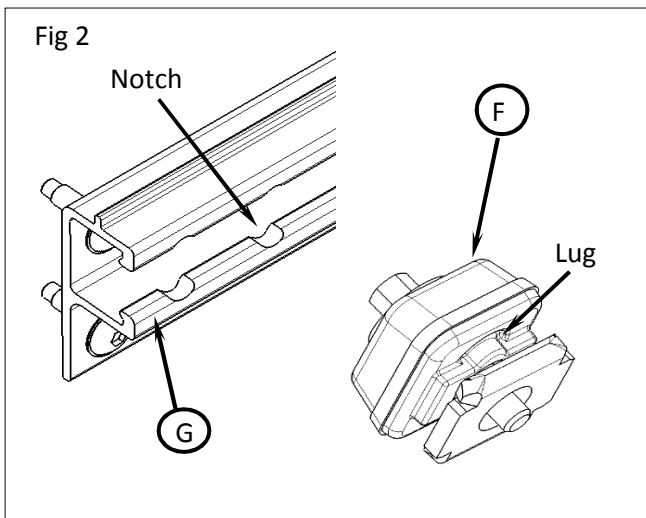

- 11) Align lugs on body (F) to notches on channel (G) in desired location. See Fig. 2

Fig 3

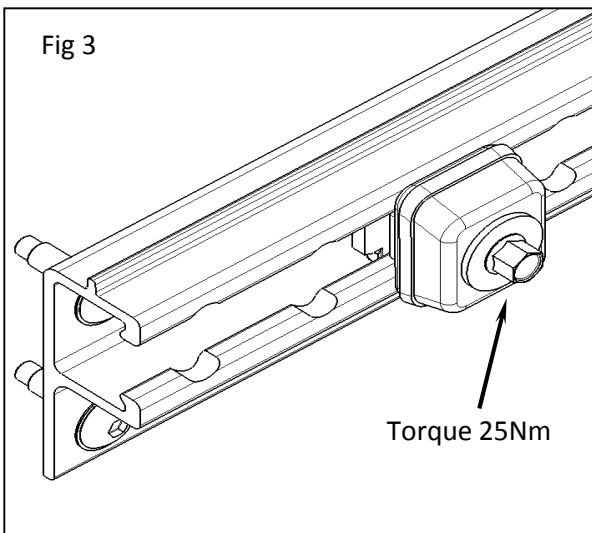

- 12) Torque bolt to 25Nm using 10mm socket wrench. See Fig. 3