



GENUINE PARTS

INSTALLATION INSTRUCTIONS

DESCRIPTION: Auto Dimming Mirror with HomeLink® and Compass

APPLICATION: Armada, SV Only

PART NUMBER: T99L1 5ZW00

KIT CONTENTS:

Item	Qty.	Part Description	Service Part Number
A	1	EC Compass HomeLink® Mirror	999L1 VZ000
B	1	Parts Kit	T98L1 5ZW01
C	1	Harness Assembly - Ignition, Battery and Ground	
D	1	Wire Cover	
E	3	Posi-tap	
F	12	Wire Tie	
G	18	Foam Tape	
H	1	Manual, Installation Instruction Download	999V2 AW000
I	1	User Guide	
J	1	A-Pillar Clip	15-53-30001
K	1	Accessory Service Connector (NOT INCLUDED IN KIT)	999Q9 AY001



A

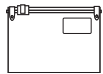

B



C



D

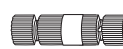

E



F

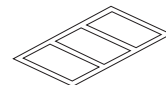

G



H

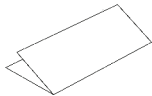

I



J

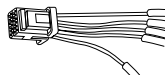

K

TOOLS REQUIRED:

3mm Flat Screwdriver

Nylon Trim Removal Tool

Clean Rag

Fish Wire

Side Cutters

#1 Phillips Screwdriver

T20 Torx Bit Screwdriver

10mm Socket

Ratchet

Fish Tape

PRE-INSTALLATION WARNINGS, CAUTIONS, CRITICAL STEPS, and NOTES:

- Dealer Installation Recommended. Instructions may refer to Service Manual.
- For HomeLink Troubleshooting refer to page 18 or call 1-800-355-3515 for assistance.

⚠ CAUTION

- **This is a universal kit so all parts may not be used.**
- **Place removed vehicle trim components in a clean, dry area to prevent damage.**

INSTALLATION PROCEDURE:

⚠ CAUTION

- Always confirm the ignition is in "OFF" position before changing switch condition.

- 1) Apply parking brake.
- 2) Confirm vehicle is no longer in default shipping state or "inventory position" as shown below. Failure to confirm vehicle has been removed from this state will result in loss of normal vehicle operation. The confirmation requires two checks:
- 3) Locate Extended Storage Switch in cabin fuse block. Confirm it is in the "Customer" position. See below for reference.
 - a) To remove transit mode(Fuse Block):
 - 1) Remove fuse cover lid.
 - 2) Push down shorting pin.
 - 3) Ign On 2 times without starting the vehicle.
 - b) To remove transit mode (BCM):
 - 1) Confirm ignition switch is in "OFF" position.
 - 2) Simultaneously push signal and wiper switch fully down for two (2) seconds.

Note: While in BCM Transit Mode, turn signal indicators will remain illuminated for one minute.

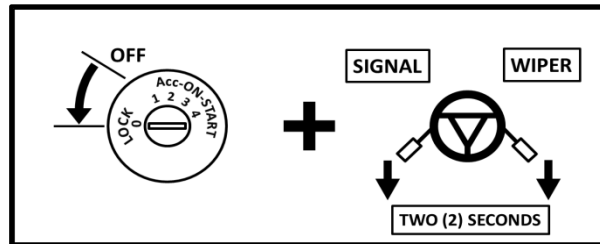
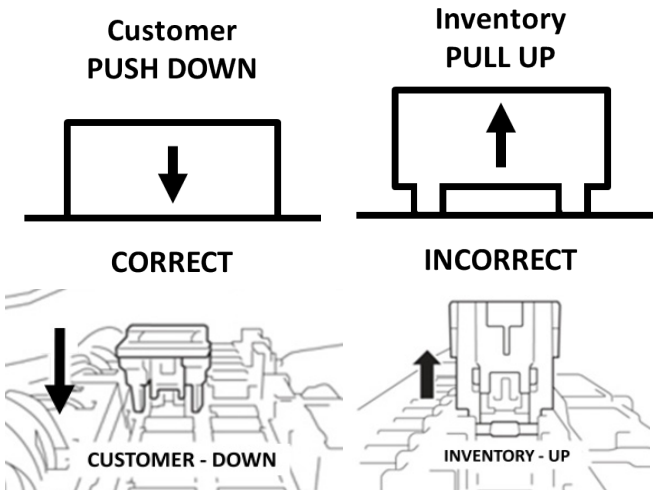

- c) To return to transit mode for storage:
 1. Ign Off.
 2. Remove the fuse cover lid.
 3. Pull up shorting pin.
 4. Assemble fuse cover lid.
 5. Ign On 2 time without turning vehicle on.
 6. Confirm transit mode condition on meter.

Note: Typical vehicle condition shown above. Identify switch by permanent push-pull fuse holder. Actual position on fuse block may vary, vehicle to vehicle.

Condition	Switch Position	Note
Vehicle is delivered to dealer	Inventory Condition	
Technician performs PDI	Customer Delivery	Return to Inventory position after PDI
Customer test drives vehicle	Customer Delivery	Return to Inventory position after test drive
Vehicle stored at dealer	Inventory Condition	
Vehicle delivered to customer	Customer Delivery	

Note: The Storage Switch is an aid to improve battery life during vehicle storage at the dealer. If the Extended Storage Switch fuse ever needs service after vehicle delivery, discard Extended Storage Switch and install correct flush in its place.

- 4) Turn ignition switch to "ON" position.
- 5) Record the customer radio presets and other presents as required.

Presets	1	2	3	4	5	6		

- 6) Put shift lever in "P" position for A/T and CVT or "1st" for M/T
- 7) Turn ignition switch to "OFF" position
- 8) Use seat and floor protection.

INSTALLATION PROCEDURE:

⚠ CAUTION

- Allow 3 min after key off and doors closed for vehicle to time out (if doors are opened again additional time may be required). Allow additional 3 min after negative terminal disconnect before separating any electrical connectors.

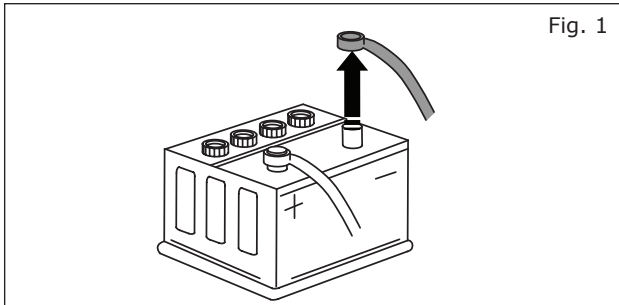

- 9) Disconnect negative battery terminal using 10mm socket and ratchet.

⚠ CAUTION

- Do not use excessive force when removing OE mirror from windshield. The window button may separate from windshield or the windshield could break.

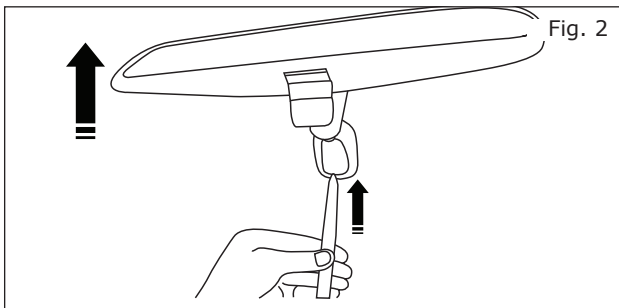

- 10) Remove OE rearview mirror.
- a) Using a nylon trim removal tool, push upward and release lock tab.
 - b) Slide mirror upward off mirror mount.

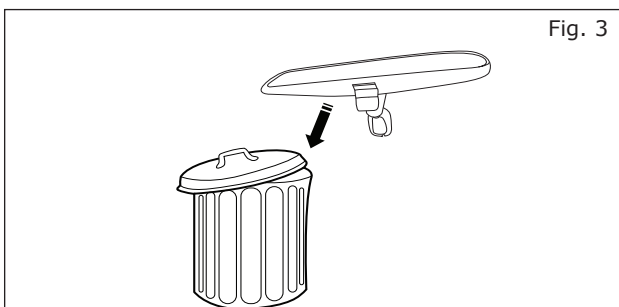
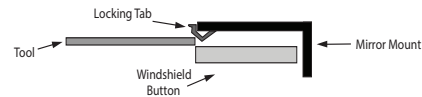

- 11) Discard mirror.

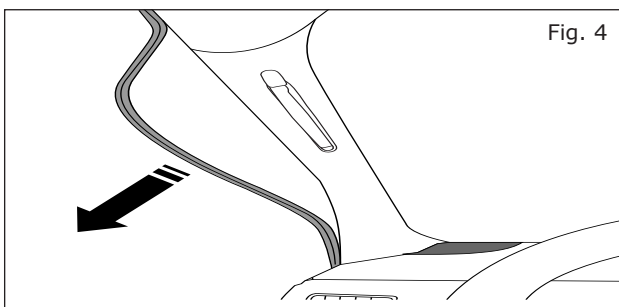

- 12) Using panel removal tool, loosen driver side weather strip and remove from top of A-pillar to instrument panel.

INSTALLATION PROCEDURE:

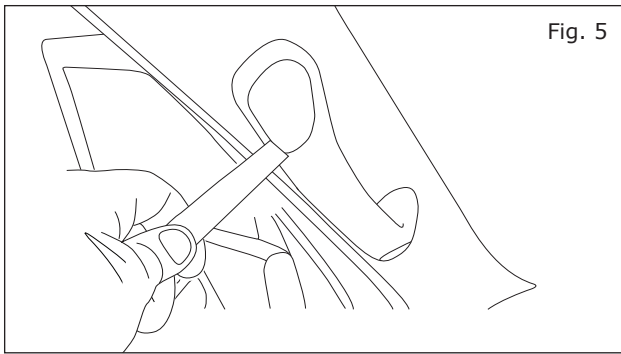

- 13) Using panel removal tool, carefully open covers on driver side handle to expose 2 bolts.

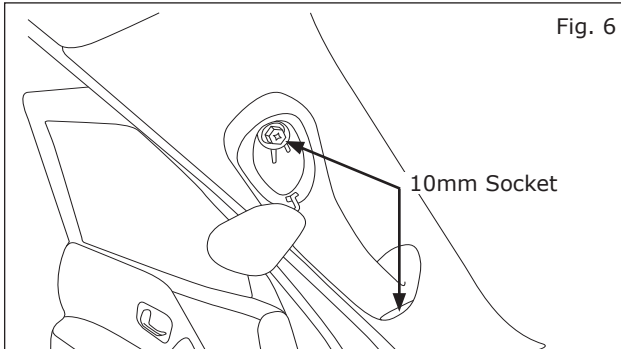

- 14) Using 10mm socket, remove 2 bolts from driver side grab handle and remove handle assembly.

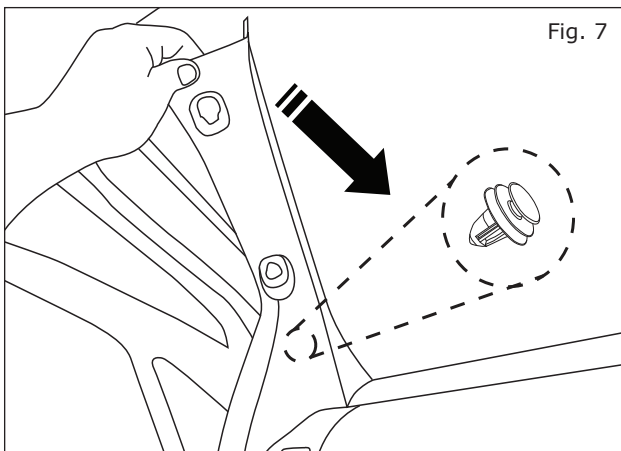

- 15) Remove A-pillar trim piece by pulling away from the a-pillar to disengage body clip and then upward to remove from dash.

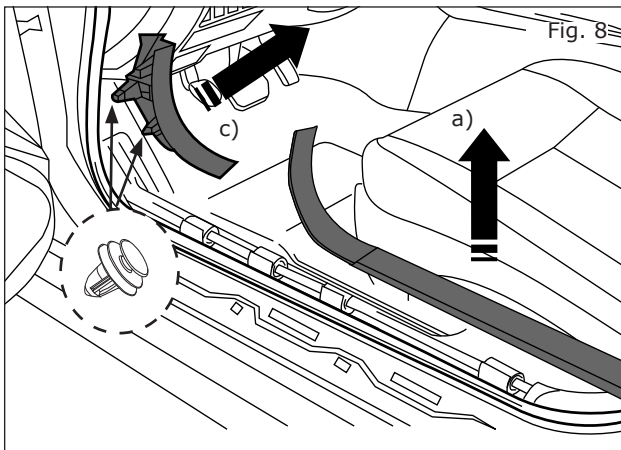

- 16) Remove the door sill plate (a) and kick panel (c) from the driver side of the vehicle.
- a) Pull up sill plate to disengage the pawls.
 - b) Remove the sill plate from the body panel.
 - c) Located in foot well, remove kick panel fixing clip by turning counter clockwise with a flathead screwdriver.
 - d) Disengage two body panels clips and remove kick panel.

INSTALLATION PROCEDURE:

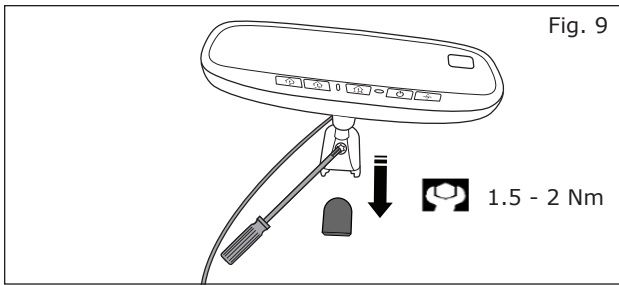

- 17) Install rearview mirror.
- Plug harness connector into back of mirror, pressing firmly until "click" is heard. Pull GENTLY on harness to confirm harness is seated completely.
 - Slide rearview mirror base over windshield button.
 - Using T-20 Torx head driver, tighten mount screw to 1.5 - 2.0 Nm (1.3 ft - lbs.)

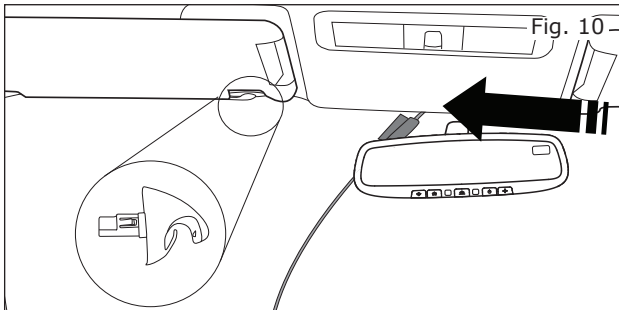

- 18) Rotate visor clip counterclockwise and remove.
- Wrap 1 piece of foam tape located at harness label and using panel removal tool, tuck harness between headliner and roof above EC mirror.

Note: Avoid pinching mirror harness when re-installing sun visor clip.

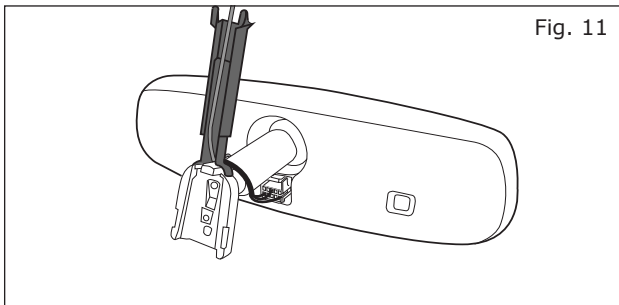

- 19) If wire cover was removed from OE mirror, discard OE wire cover and use new wire cover from kit contents.
- Route harness into the groove of wire cover and attach to mirror mount.
 - Slide forks on top of wire cover and into headliner cut out.
 - Verify cover is properly seated and aligned to headliner cut out.

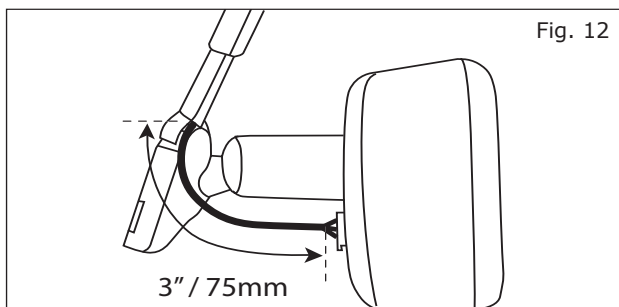

- 20) Verify that approximately 3" (75mm) of wire are between bottom of wire cover and connector. Failure to allow appropriate length will result in limited to no adjustment tolerance. Route harness on drive side of mirror mount as shown.

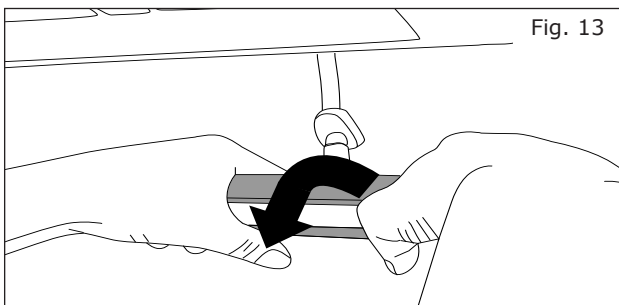

- 21) Grasp mirror and rotate downward. Check to ensure wire cover sits flush against windshield.
- If a gap exists between wire cover and windshield, ensure there is enough harness slack from mirror to the headliner. Adjust if necessary.

INSTALLATION PROCEDURE:

CAUTION

Exercise caution when routing mirror harness to avoid air bag and interference with air bag deployment. Do not mount harness to air bag components.

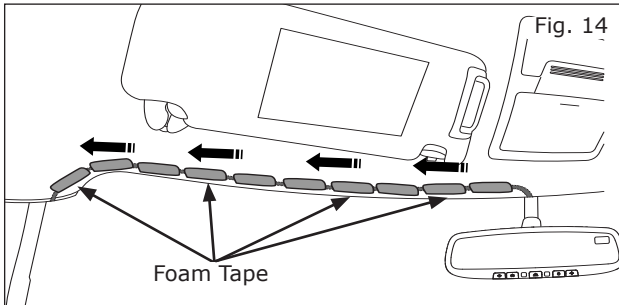

- 22) Wrap nine additional pieces of foam tape around mirror harness, evenly spaced apart routed along headliner as shown. Wrap foam using long side of foam.

a) Using panel removal tool, tuck the wire harness between headliner and roof.

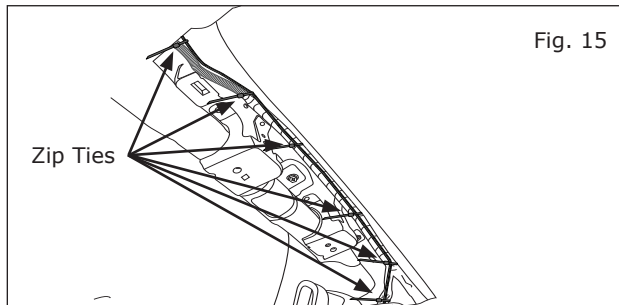

- 23) Route harness down driver side A-pillar and secure harness to vehicle a-pillar body using 6 wire ties.

Note: Secure harness at factory harness clips whenever possible. Avoid Contact or interference to curtain airbag.

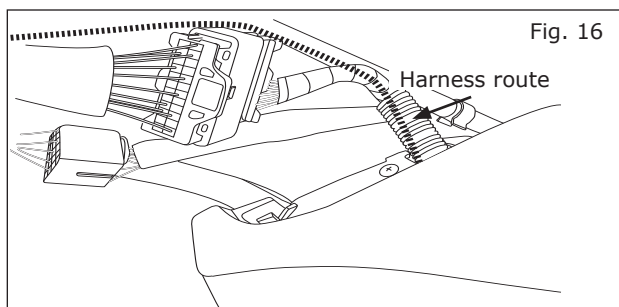

- 24) Route harness in between dash and a-pillar along factory harness.

a) While looking under the glove box use fish tape to feed harness from upper dash to lower driver side kick panel area.

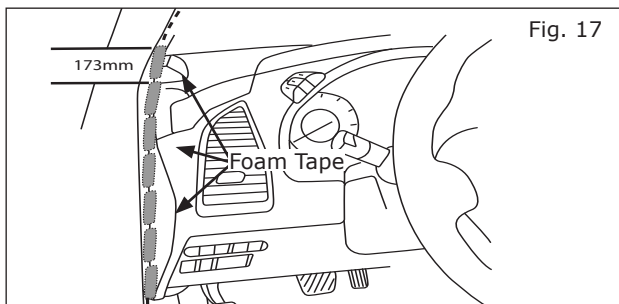

- 25) Partially pull back mirror harness to apply foam tape spacing evenly 173mm apart.

a) Wrap 7 pieces of foam tape around mirror harness. Locate first foam tape slightly above cockpit transition from a-pillar into dash and space the remaining foam tapes as shown. Wrap foam using long side of foam.

Note: Follow vehicle harness when possible and take caution to avoid sharp edges.

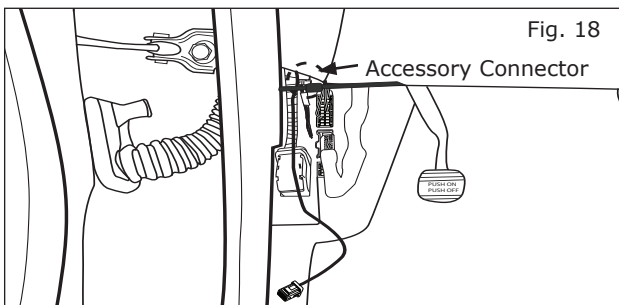

- 26) Pull harness taught and secure with 1 wire tie.

a) Locate driver side Accessory Service Connector up under dash along left side of fuse block.

Note: Previously installed accessory connector may be present. If so, carefully remove accessory connector harness from plug before posi-tapping. It is recommended that all posi-tapping be completed before reattaching accessory connector to plug.

INSTALLATION PROCEDURE:

CAUTION

This Accessory Service Connector is for use only with Genuine Nissan (or Infiniti) or Nissan (or Infiniti) approved accessories. Use of this connector with non Genuine Nissan (or Infiniti) or Nissan (or Infiniti) approved accessories or failure to follow the installation instructions for the connector contained in this package may result in damage to the accessory and/or your vehicle. Nissan (or Infiniti) is not liable for loss or damage due to improper installation or the installation of non Genuine or non approved accessories.

Posi-Tap™ is protected by patent # 5,228,875 5,695,369 5,868,589 6,692,313 Jap 2881414 Aus 708700 Tia 103534 Can 2204826 Mex 200626 Korea 477279 China Z197105562.9 & others pending.

Fig. 19

999Q9 AY001		
Pin	Label	Color
1	IGN	WHITE
2	BAT	RED
3	TL LMP	PURPLE
4	RM LMP	YELLOW
5	BATSVR	PINK
6	FR DR SW RH	GRN
7	FR DR SW LH	LT GRN
8	THRU SIGNAL 1	GREY
9	RR DR RH	BLUE
10	RR DR LH	LT BLUE
11	ACC	ORANGE
12	GND	BLACK

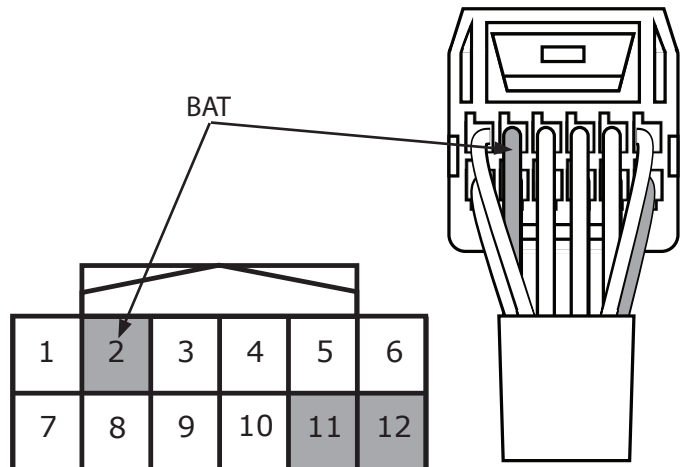

 **Identify red tape surrounding pigtail on service connector and that all circuits are populated.**

- 27) Using posi-tap, connect BLACK WIRE W/WHITE TRACE AND SILVER CONDUCTOR from mirror harness to BLACK wire on accessory connector harness. Using a posi-tap, connect the BLACK WIRE W/ORANGE TRACE & COPPER CONDUCTOR from the mirror harness to the ORANGE wire on the accessory connector harness. Using a posi-tap, connect the BLACK WIRE & COPPER CONDUCTOR from the mirror harness to the RED wire on the accessory connector harness.

- Reference Page 19 for additional wiring details.**
- See Step 23 - 37 for posi-tap installation instructions.

 **Verify mirror has been wired properly.**

**Note: Be sure NOT to posi-tap through the shrink tubing.
HARNESS NOT INCLUDED IN KIT. REFERENCE PART NUMBER 999Q9 AY001**

INSTALLATION PROCEDURE:

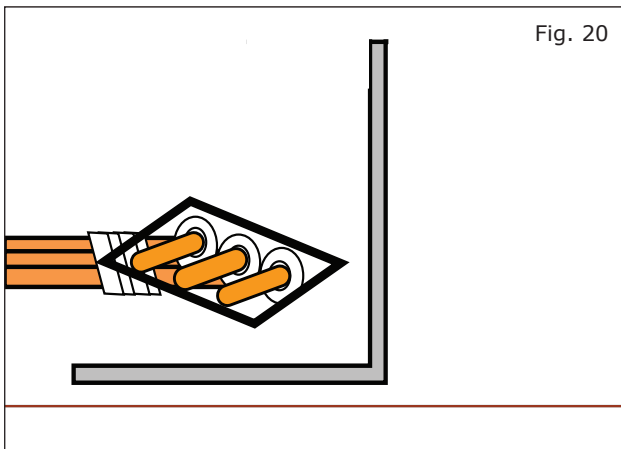

- 28) Tap accessory service wire.
- Identify and confirm correct wire in the Accessory Service Connector to be tapped.
 - Remove cap (slot side) from tap body.
 - Slide cap around single accessory wire.
 - Position cap $\geq 6.35\text{mm}$ (0.25in) away from the heat shrink end of the Accessory Service Connector (measurement for first posi-tap installed on the circuit).
 - Tighten the tap **TIGHT** with finger pressure.
 - Tighten by another quarter turn.

NOTE: Figures are not to scale.

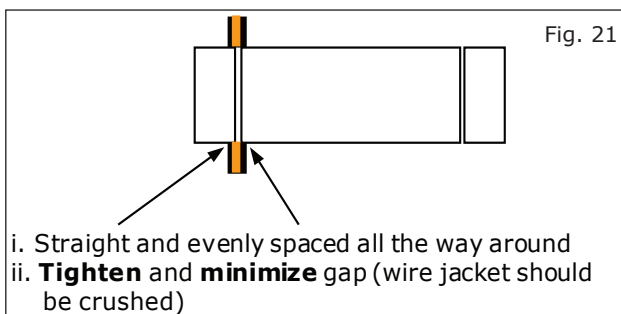

- 29) Inspect the tap to ensure correct installation.
- Pull on wire lightly to ensure connection.
 - Inspect the tap to ensure correct installation.
 - Test signal to ensure that it is working.

NOTE: Avoid putting pressure on the vehicle wire and tap for the remainder of the installation.

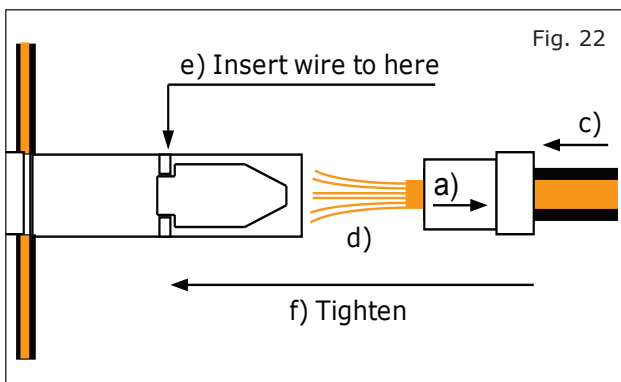

- 30) Tap accessory wire.
- Remove tap (non-pierce) side from tap.
 - Remove the protective stub from the wire.
 - Insert wire through the non-pierce side.
 - Spread the individual strands into fan shape.
 - Insert wire into the tap body and ensure that it is all the way in.
 - Tighten the tap **TIGHT** with finger pressure.
 - Tighten by another quarter turn.

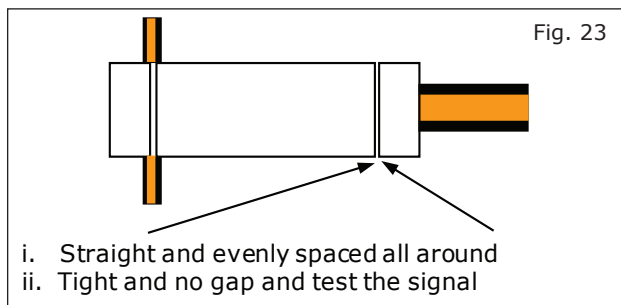

- 31) Confirm the tapped accessory wire.
- Pull on the wire lightly to ensure connection.
 - Inspect the tap to ensure correct installation.
 - Test the signal to ensure it is working.

INSTALLATION PROCEDURE:

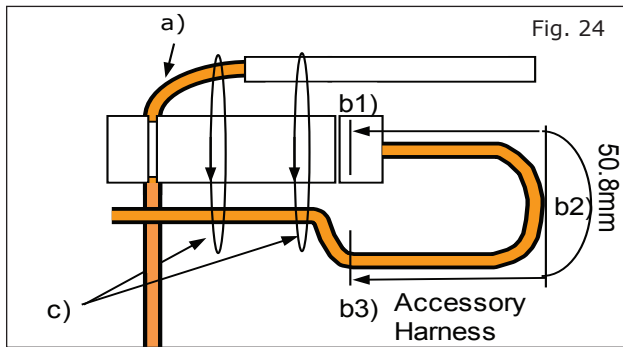

- 32) Forming strain relief loop (always required).
- Gently bend the end of the pierced wire (where it exits the cap) down toward the body of the posi-tap.
 - On the tapped wire of the non-pierce side; starting at point b1) measure 50.8mm(2in.) to point b3). Make the first bend of the loop b2), half the distance measured 25.4mm(1in.), and up toward the body of the posi-tap, make the second bend of the loop b3).
 - Secure the pierced wire on the heat shrink side and the tapped wire on the non-pierce side to the body of the tap with electrical tape (≥ 2 Revolutions).

NOTE: If securing multiple taps to single circuit continue to Step 28, if tapping different circuits repeat steps 23-27 as required, then proceed to step 32.

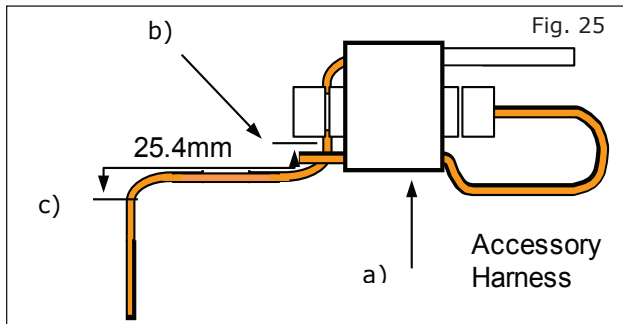

- 33) Multiple posi-taps on the same wire; first tap.
- The first accessory is tapped, relieved and secured as shown in Fig 17 thru 21 (these steps are always the same).
 - Measure 25.4mm(1in) from point b) to point c) on the pierced wire.
 - At points b) & c), bend the pierced wire gently to form the "staircase" shape.

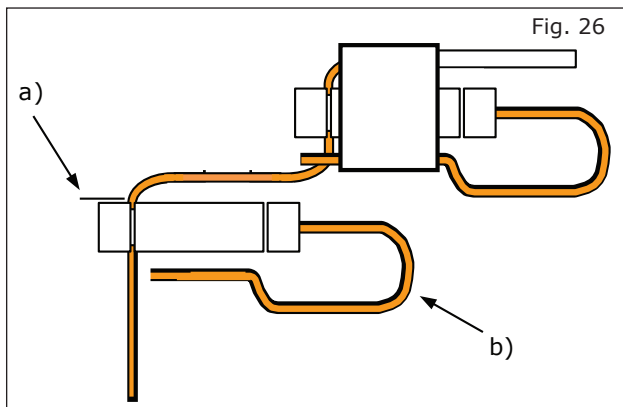

- 34) Multiple posi-taps; second accessory.
- Tap second accessory at point b), making sure to preserve "staircase shape".
 - After tapping second accessory, form a strain relief loop for the tapped wire on the non-pierce side as shown in Fig c) and detailed in step 5b.

NOTE: Do not secure before reading step 30. Repeat as necessary.

INSTALLATION PROCEDURE:

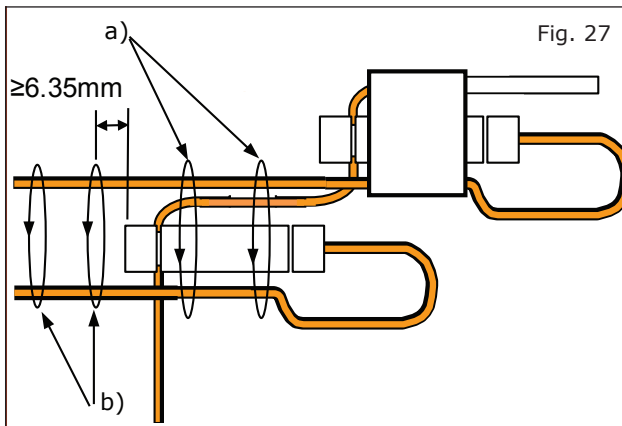

- 35) Securing multiple posi-taps on the same circuit
- Secure the pierced and tapped wires from the first posi-tap, along with the tapped wire from the non pierce side of the 2nd posi-tap to the body of the 2nd tap with electrical tape (≥ 2 revolutions).
 - Secure the tapped wires from the non-pierced sides of each tap to each other with electrical tape (≥ 2 revolutions) at a distance of $\geq 6.35\text{mm}$ (0.25in) from the head of last posi-tap shown in Fig b).

Note: No single wire should be posi-tapped more than 4 times to maintain integrity. Repeat as necessary

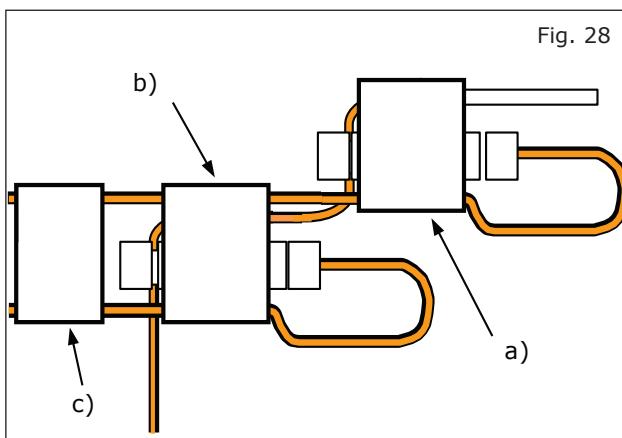

- 36) Multiple accessory taps on the same circuit secured.
- The first accessory is tapped, relieved and has the pierced wire on the heat shrink side and the tapped wire on the non-pierce side secured to the first tap as shown in Fig a).
 - The second accessory is tapped, relieved and has the pierced wire, the tapped wire on the non-pierce side and the tapped wire from the non-pierce side of the first posi-tap secured to the second tap as shown in Fig b).
 - Finally the tapped wires on the non-pierce side of the first and subsequent posi-taps are secured to each other as shown in Fig c).

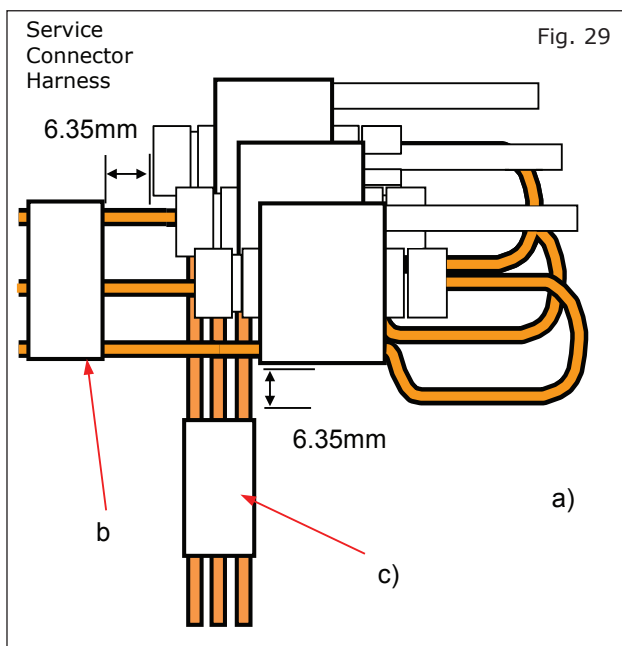

- 37) Multiple accessory taps on different circuits secured together.
- The tapped accessories (with wires already secured to tap bodies) are stacked slightly staggered on top of each other as shown in Fig a).
 - The tapped wires on the non-pierce side of all the posi-taps are secured to each other with electrical tape (≥ 2 revolutions) at a distance of $\geq 6.35\text{mm}$ (0.25in) as shown in Fig b).
 - The pierced wires of the first and subsequent posi-taps are secured to each other with electrical tape (≥ 2 revolutions) at a distance of $\geq 6.35\text{mm}$ (0.25in) as shown in Fig c).

INSTALLATION PROCEDURE:

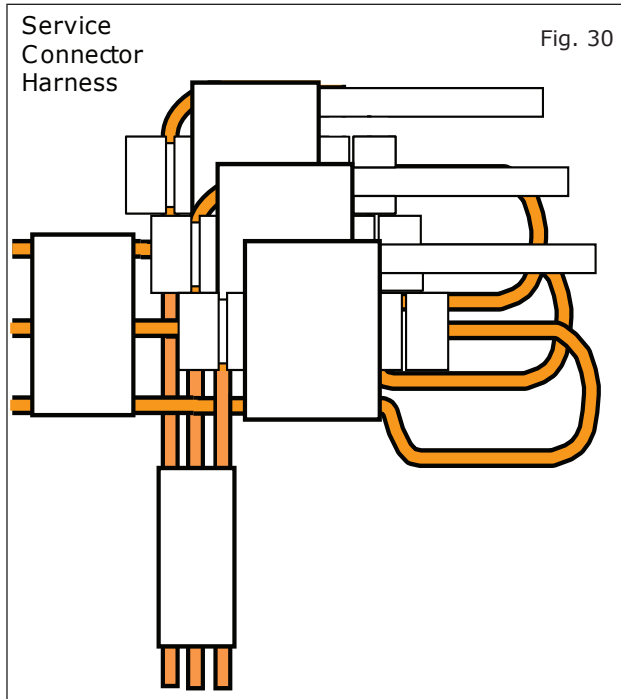

- 38) Prep for foam wrap.
- Make sure accessory taps have been wrapped appropriately as detailed previously and as shown in Fig 26.

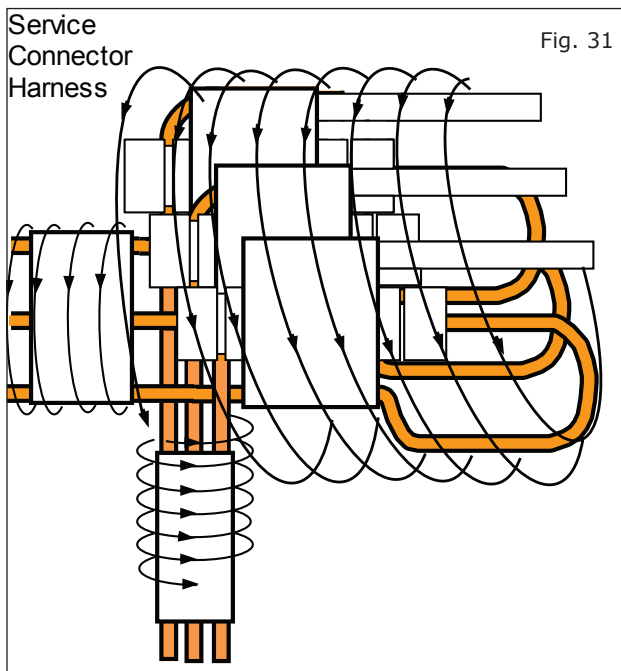

- 39) Pre- foam protective wrap.
- Starting at the heat shrink; firmly wrap the posi-tap bundle with electrical tape or non-adhesive wire harness tape, making sure to overlap the previous revolution.

Note: If using non adhesive tape secure at the of wrap with electrical tape ≥ 2 revolutions.

INSTALLATION PROCEDURE:

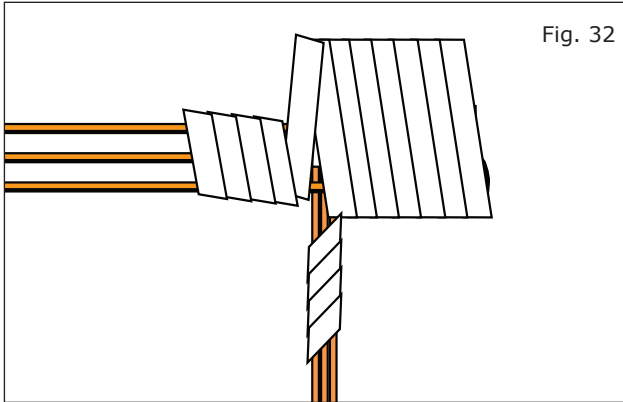

- 40) Finished protective wrap.
a) Make sure finished wrap looks similar to Fig 39.

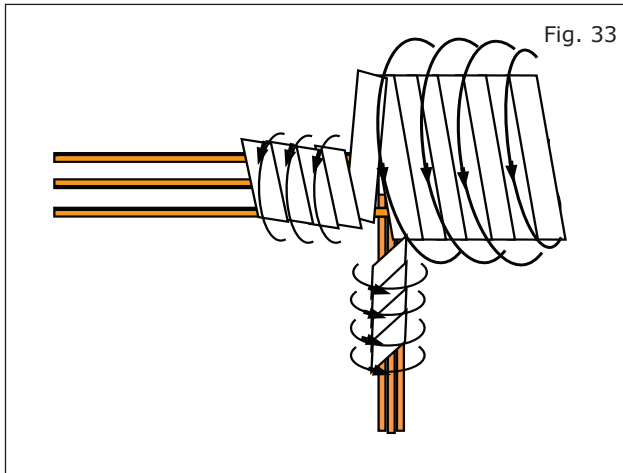

- 41) Foam wrap for posi-tap bundle (foam strips)
a) Wrap posi-tap bundle with foam tape, following a pattern similar to the electrical tape, making the best use of foam strips provided.

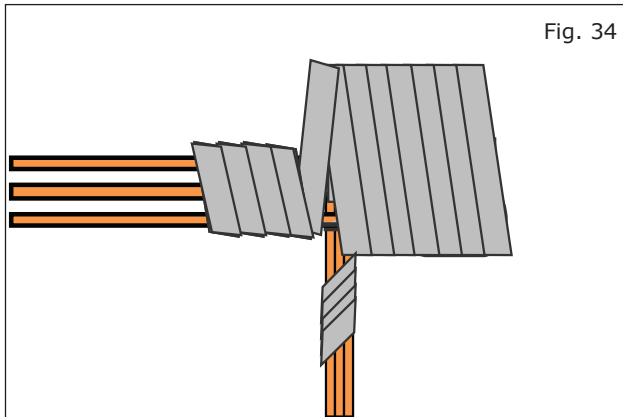

- 42) Finished foam wrap for bundle (strips-top view)
a) Make sure the finished wrap looks similar to Fig 34.

INSTALLATION PROCEDURE:

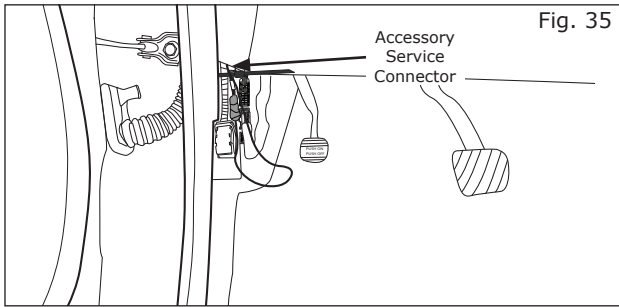

- 43) Route Accessory Service Connector up under dash to accessory connector plug and plug connectors together.

Note: Be sure the new harness routing does NOT interfere with the emergency brake in any way.

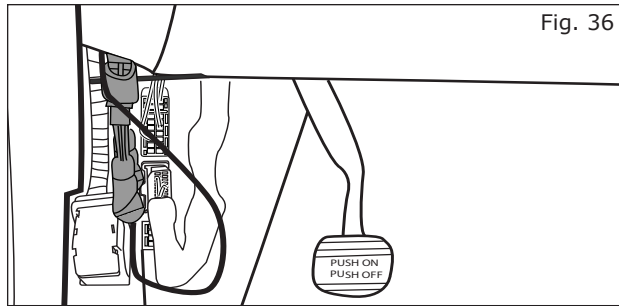

- 44) Wrap connectors with 1 piece of foam tape.

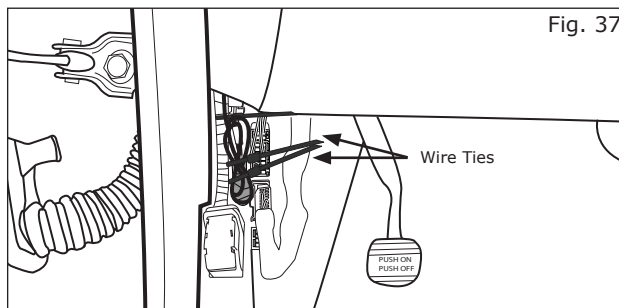

- 45) Route any extra wire along existing harness, and bundle EC mirror harness to main body harness with 2 wire ties.

- 46) Re-install all trim parts removed/uninstalled.

ACCESSORY CHECK:

Note: If errors are encountered during testing and compass calibration, see diagnostic flow charts, pages 16-18.

Testing

- Tighten negative battery terminal nut to 5.4 Nm (47.8 in-lb).
- With ignition switch OFF, push each HomeLink® button one at a time and verify that the LED indicator to the left of the center switch illuminates with a red LED (Fig. 39).
- Turn the ignition switch to ON.
- Ensure vehicle is in well lit area.
- Check to see that the green LED is illuminated. If it is not, press the "⏻" button to turn it on.
- Cover the forward-looking photocell (located to the driver side of the wire harness connection on the back of the mirror) with a dark cloth or towel. After a few seconds, the mirror should begin to darken. Timing will vary with ambient light levels and a flashlight may be shined on the rearward photocell if needed, to accelerate effect. (Fig. 38)

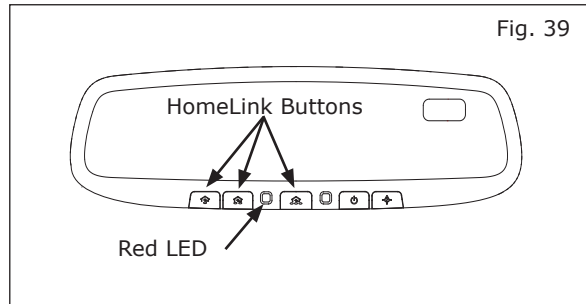
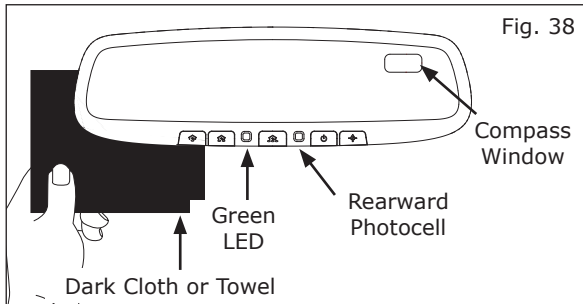

- Remove the cover from the forward-looking photocell and the mirror will begin to clear.
- Push the "⬆️" button to ensure compass display shows either a direction such as "NE" or a "C", and that it can be turned ON and OFF.
- Testing is now complete.

Set Compass Zone

- With the display turned "ON", push the "⬆️" button for 3 seconds, until a number appears in display (numbers correspond to regional compass zones).
- Press and release "⬆️" button to scroll through zone numbers.
- Release "⬆️" button when correct zone number is displayed (Fig. 40). Zone number will disappear and display will return to showing either a directional heading or a "C" after 5 seconds of no switch activity.

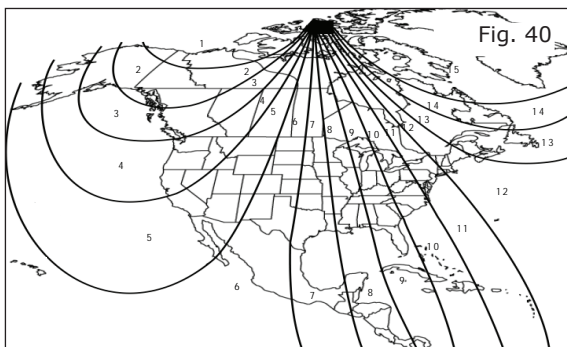

Calibrate Compass

- Drive vehicle in circles (360°) at 5 mph or less until compass display window shows a direction.
- Check all **Critical Installation Steps**.
- Check all torque values
 - Auto-Dimming mirror, pg. 5, step 17.

ACCESSORY CHECK:

- Verify all wiring is secure and not exposed.
- Trim all excess cable ties flush.
- Check all vehicle electrical systems that the accessory interfaces with.
 - Power mirror switch.
 - Traction control switch.
 - Hood Release
 - Fuel Door Release

RE-INSTALLATION OF REMOVED PARTS:

⚠ CAUTION

Use caution when re-installing interior components to avoid damage, scratches, or breaking of mounting clips. Refer to the vehicle service manual for more information.

- LH front pillar garnish.
 - Insert new clip (P/N 15-53-30001) into garnish.
 - Align indicator arrow pointing upward located on backside of driver side grab handle. (Fig. 42)

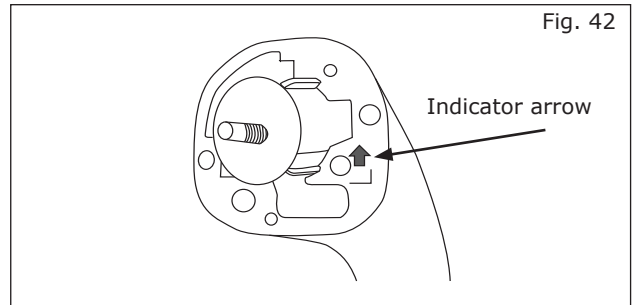
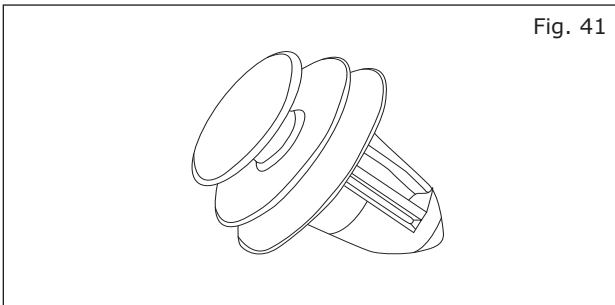

FINAL INSPECTION:

- Verify re-installed trim parts for proper flush fit (no gap, no waviness, etc).
- Verify all clips are fully engaged and locked.
- Verify re-installed trim parts are free from cracks, scratches, or stress cracks.
- Verify vehicle headliner, seat, steering wheel, center console, floor carpets, etc. are not soiled.
- Verify interior and exterior is not damaged.
- Turn ignition switch to "ON" and confirm proper operation of Vehicle Systems.
 - If equipped, verify all window and sunroof one touch operation and perform the reset procedure if necessary. Refer to the vehicle service manual for more details.
 - Confirm proper audio function (AM, FM, SAT, CD and AUX).
- Re-program radio presets and other vehicle settings to the recorded settings.
- Start engine and verify that there are no new Diagnostic Trouble Codes. Turn ignition switch to "OFF".
- Place the Owner Manual, Quick Reference Guide, and/or other Manual in the glove box.

DIAGNOSTIC FLOW CHART:

Before attempting to trouble-shoot EC mirror Auto-Dimming function, ensure the following:

1. Mirror is manufactured by **Gentex Corporation** (the letters **GNTX** will be etched onto the back of the mirror and the compass display window will be in the mirror glass).
2. EC mirror harness must be fully plugged into EC mirror.
3. Vehicle ignition must be in the **"ON"** position.

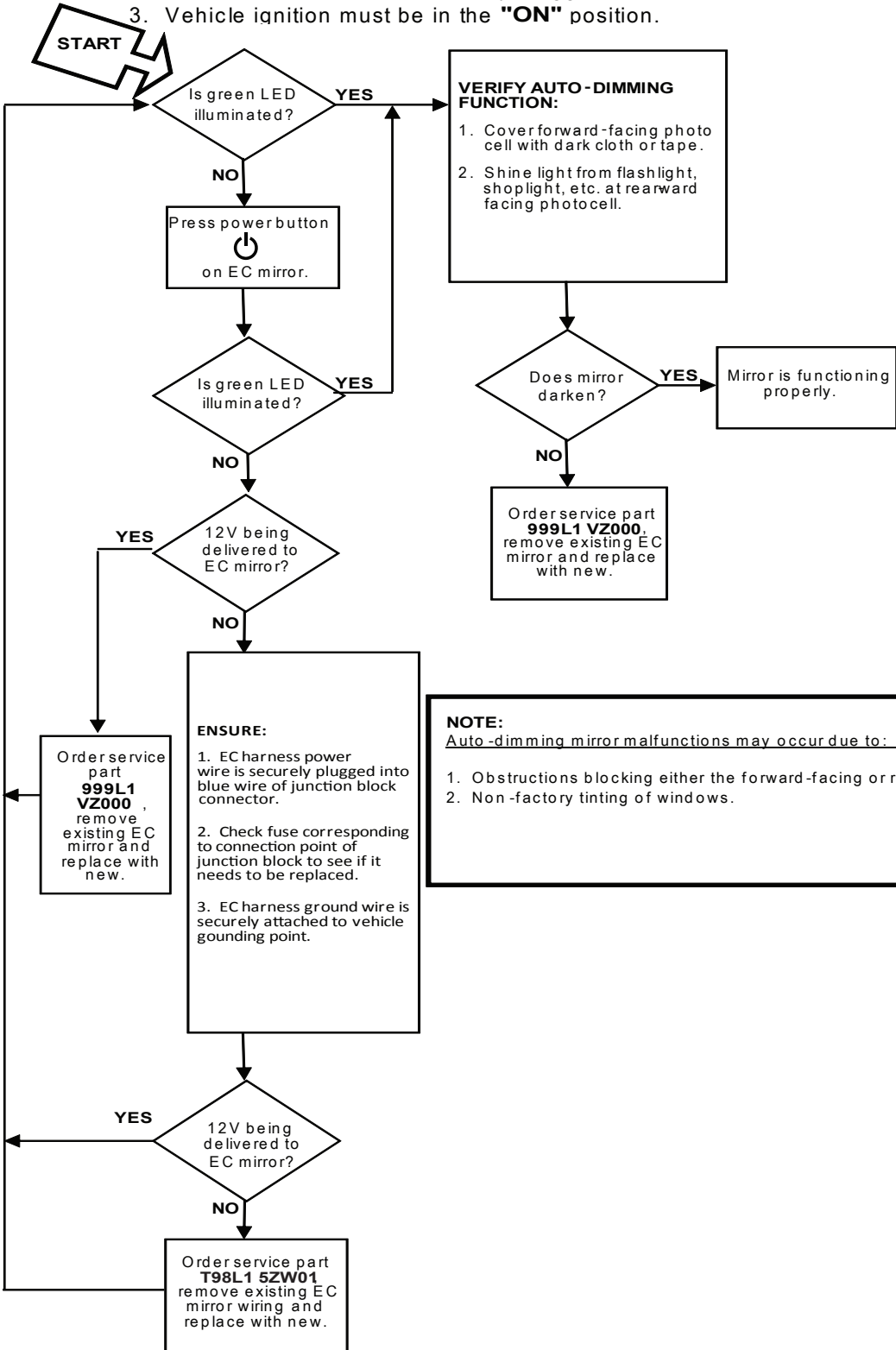

NOTE:
Auto-dimming mirror malfunctions may occur due to:

1. Obstructions blocking either the forward-facing or rearward-facing photo-cells.
2. Non-factory tinting of windows.

DIAGNOSTIC FLOW CHART:

COMPASS TROUBLE-SHOOTING GUIDE

Part Number: 999L1 VZ000

Before attempting to trouble-shoot EC mirror compass function, ensure the following:

1. Mirror is manufactured by **Gentex Corporation** (the letters **GNIX** will be etched onto the back of the mirror and the compass display window will be in the mirror glass).
2. EC mirror harness must be fully plugged into EC mirror.
3. Vehicle ignition must be in the **"ON"** position.

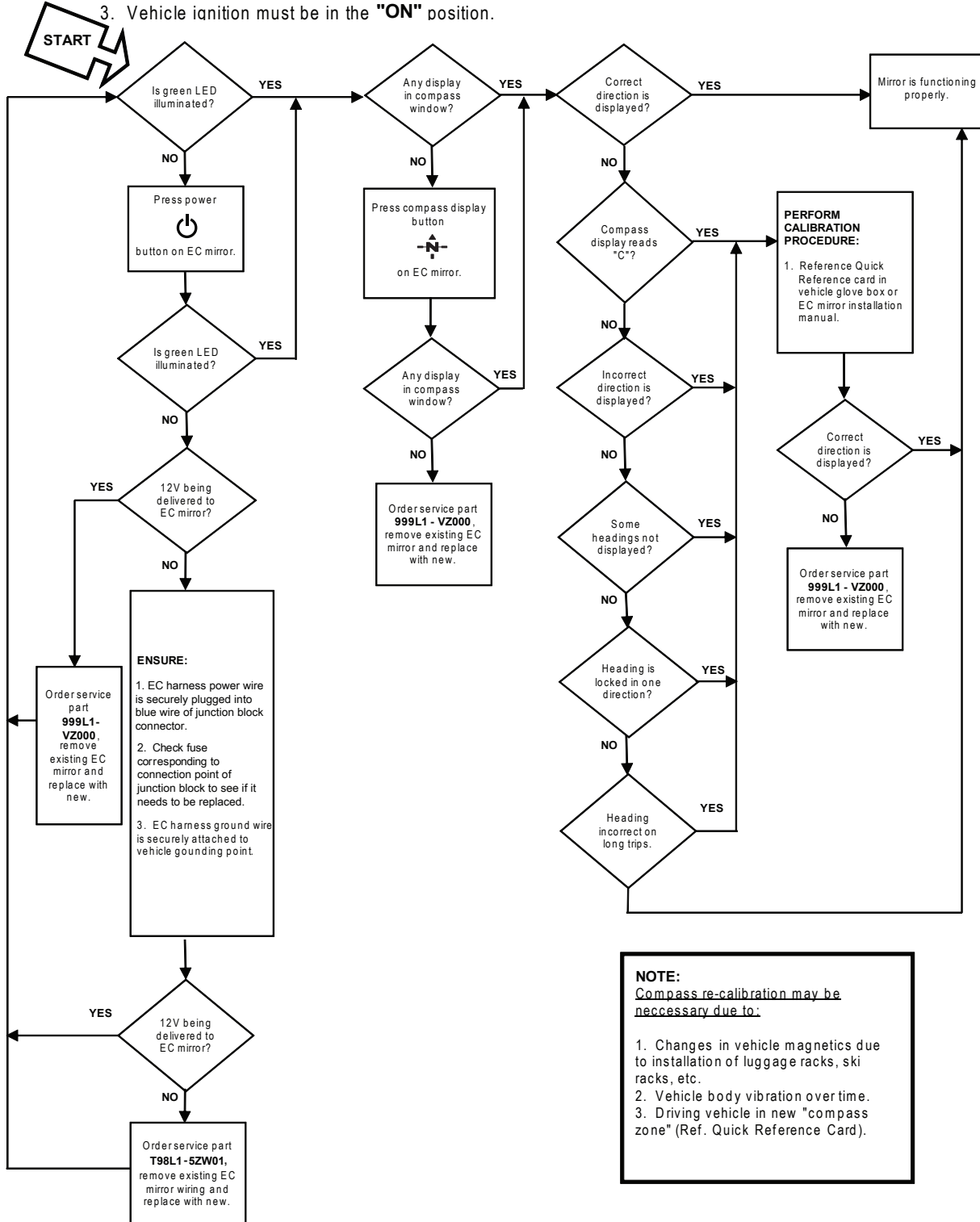

NOTE:
Compass re-calibration may be necessary due to:

1. Changes in vehicle magnetics due to installation of luggage racks, ski racks, etc.
2. Vehicle body vibration over time.
3. Driving vehicle in new "compass zone" (Ref. Quick Reference Card).

DIAGNOSTIC FLOW CHART:

HOMELINK® TROUBLE-SHOOTING GUIDE

Part Number: 999L1 VZ000

Before attempting to trouble-shoot EC mirror HomeLink® function, ensure the following:

1. Mirror is manufactured by **Gentex Corporation** (the letters GNTX will be etched onto the back of the mirror and the compass display window will be in the mirror glass).
2. EC mirror harness must be fully plugged into EC mirror
3. Vehicle ignition must be in the "ON" position.

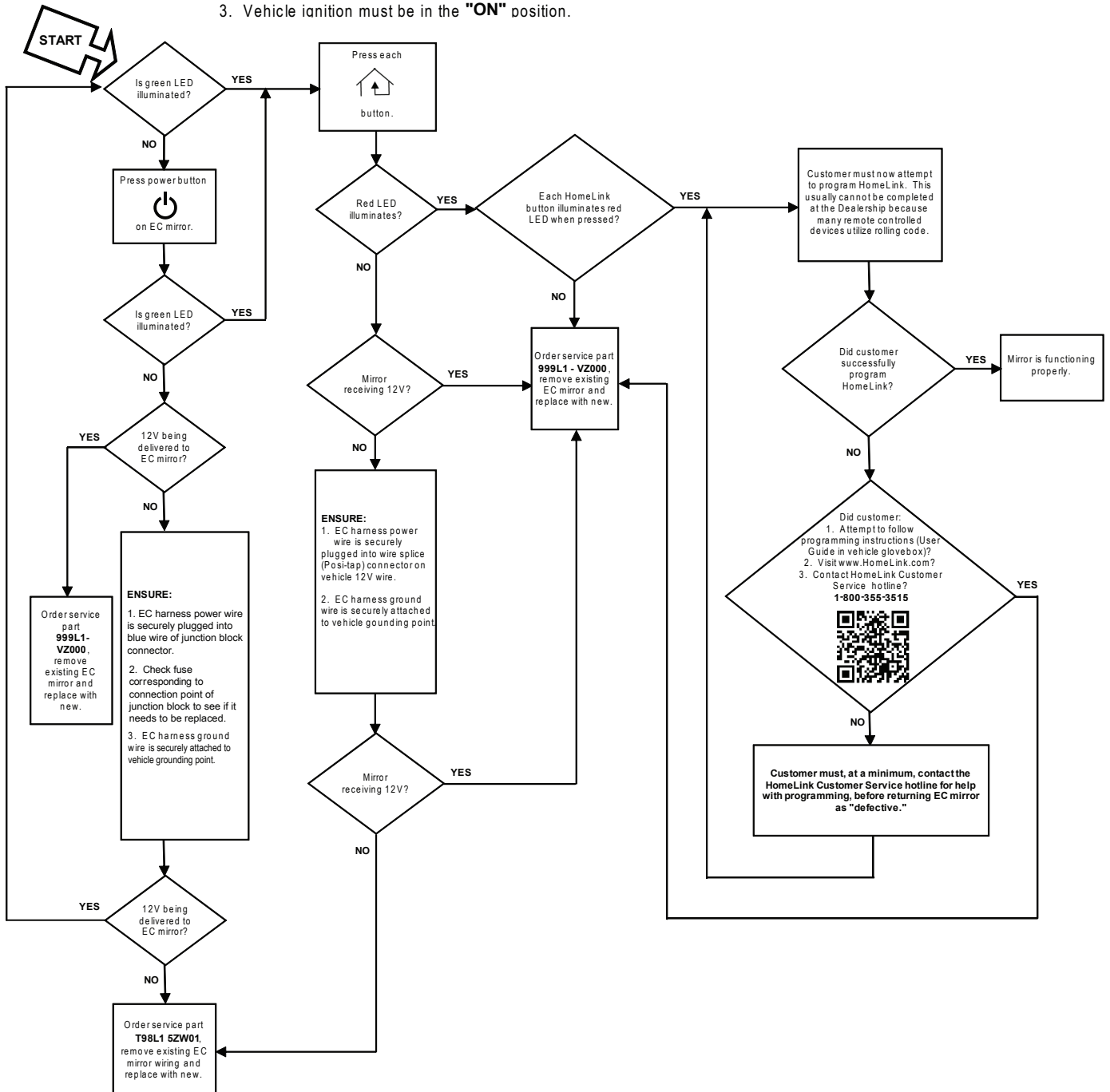

HomeLink® and the HomeLink® house are registered trademarks of Gentex Corporation.

DIAGNOSTIC FLOW CHART:

EC MIRROR KIT

ACCY_SER_CONN

IGN	1	WHT
BAT	2	RED
TAIL_LAMP	3	PURP
ROOM_LAMP	4	YEL
BAT_SAVER	5	PNK
FR_DOOR_SW_RH	6	GRN
FR_DOOR_SW_LH	7	LT_GRN
THRU_SIGNAL_1	8	GRY
RR_DOOR_RH	9	BLU
RR_DOOR_LH	10	LT_BLU
ACC	11	ORG
GND	12	BLK

TH12FW-NH

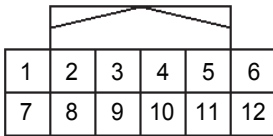

Note: Pin location is referenced looking into wire side of connector.

