



GENUINE PARTS

INSTALLATION INSTRUCTIONS

1. DESCRIPTION:	Tow Hitch Finisher
2. APPLICATION:	Pathfinder
3. PART NUMBER:	999T5 X5190

4. KIT CONTENTS:

Item	Qty.	Part Description	Service Part Number
A	1	Tow Hitch Finisher	999T5 X5191
B	1	Cutting Template	999T5 X5192
C	1	3M™ Adhesion Promoter 4298	"Not Available"
D	3	Spring Nut	12-41 00771
E	3	Screw	14-51 00841
F	1	Installation Instructions Replacement Template	N/A

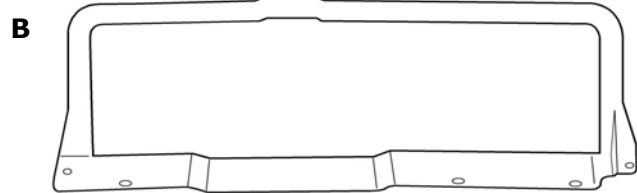
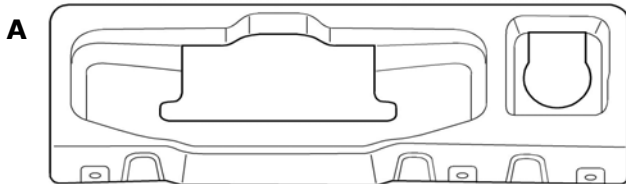

C



D



E



F

5. TOOLS REQUIRED

- Small reciprocating air saw with small fine-tooth blade
- Clean, Lint-free cloth
- 90% or greater isopropyl alcohol
- Drill with 8mm & 6mm Drill Bits
- Flathead Screwdriver
- Phillips Screwdriver
- Utility Knife
- Protective Gloves
- Masking tape
- Safety Glasses

6. PRE-INSTALLATION CAUTION/NOTES

- Dealer installation recommended. Instructions may refer to Service Manual
- Installation may require special tools
- This part is to be installed at a surface temperature no warmer than 65-100°F

⚠ CAUTION

- This accessory must only be installed as specified in these instructions.
- Ensure at all times that parts are securely fitted and will not compromise the safe function of vehicle systems.

7. INSTALLATION OVERVIEW

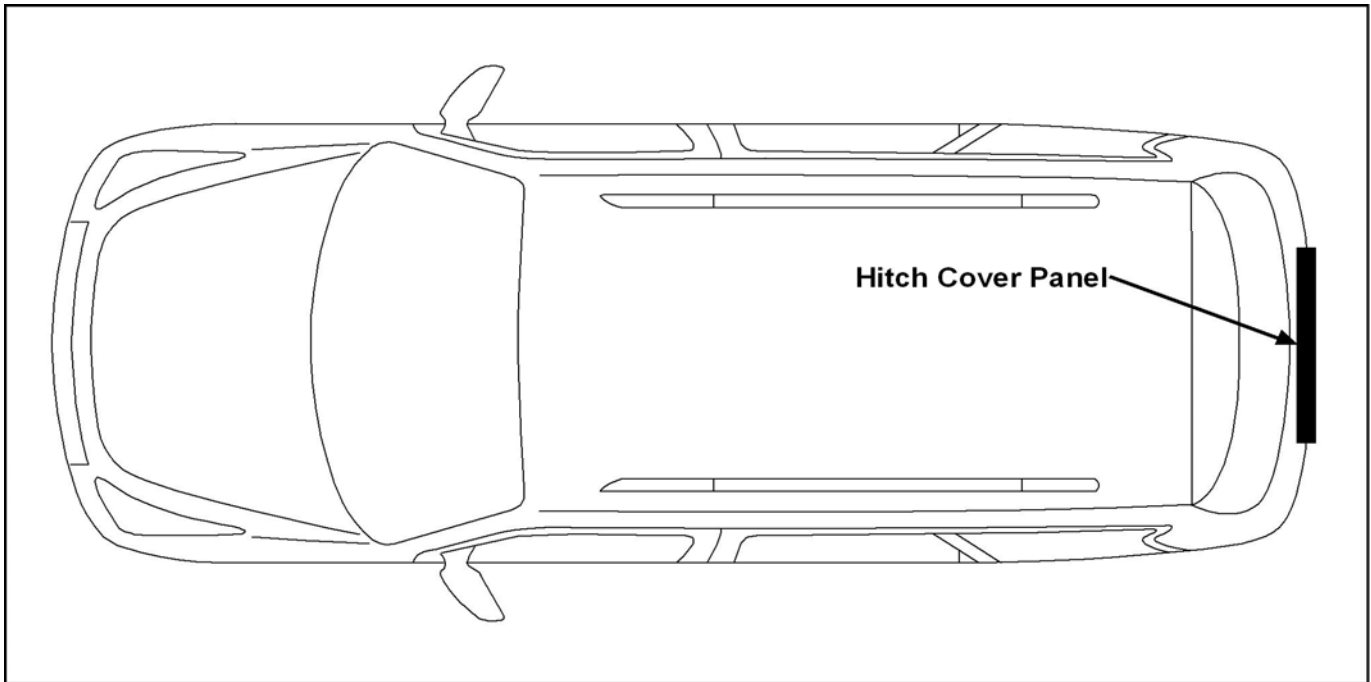

8. CRITICAL STEPS

The following steps are critical and must be performed **EXACTLY** as specified to ensure proper installation:

- Location of the cover panel must be followed exactly as described in this instruction.
- Be sure to apply masking tape as needed in order to protect any areas that may become scratched or damaged.
- Test the functionality of the kit before final clean up.

9. Order of Installation

1. Mount template.
2. Cut hole for Cover Panel.
3. Mount Cover Panel.

10. INSTALLATION PROCEDURE

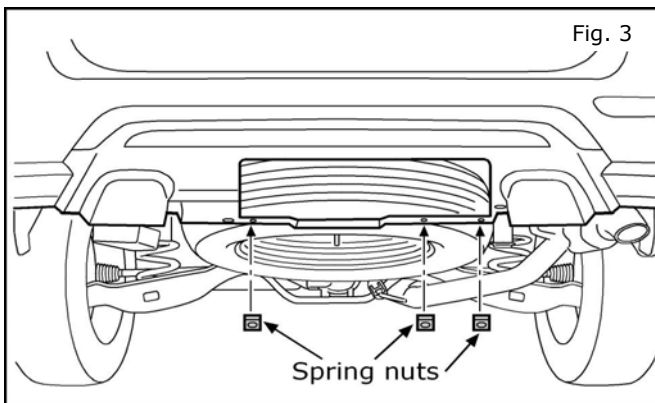
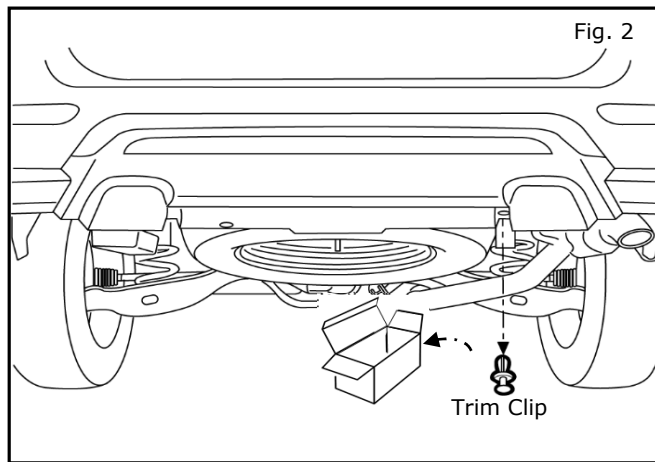
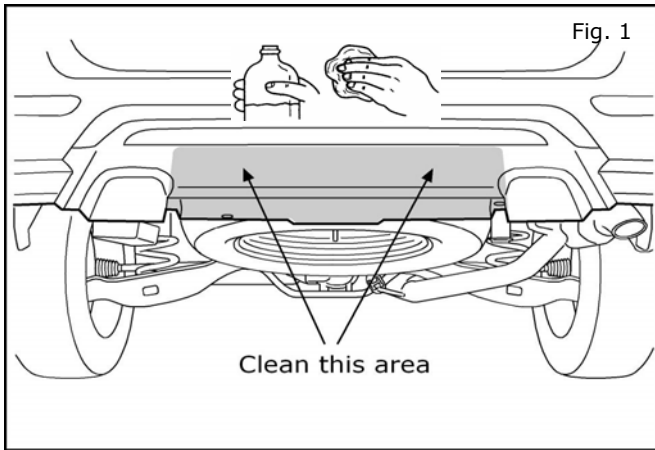

NOTE:

Before starting, confirm installation of the following part has been started before proceeding further: Trailer Tow Harness (999T8 YZ000)

- 1) Raise Vehicle on hoist to working height.
- 2) Use clean, lint-free cloth to clean installation surface (shaded area) with isopropal alcohol and water solution. Use at least 90% alcohol solution.
 - a) Allow the alcohol to dry completely.
- 3) Use a flathead screwdriver to remove one (1) trim clip from the under side of the bumper.
 - a) Save trim clip for next step.
- 4) Install three (3) Spring Nuts to inside bottom edge of fascia as shown in Fig 3.

10. INSTALLATION PROCEDURE

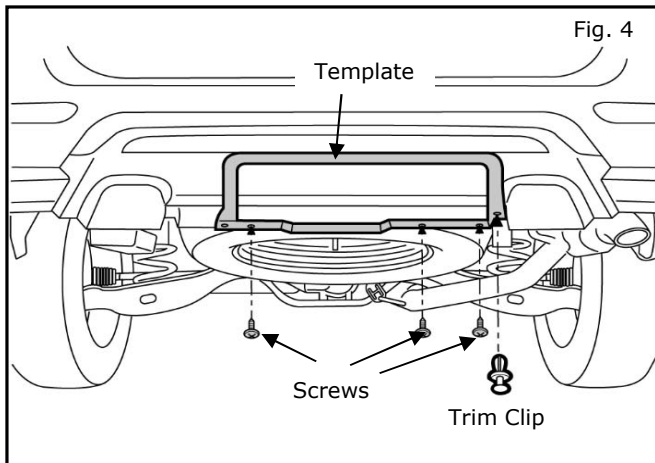

- 5) Position cutting template to rear bumper by lining up holes in cutting template to holes in rear fascia, as shown in Fig 4.
 - a) Reinstall the one (1) trim clip previously removed in step 2.
 - b) Push firmly on clips to ensure they are properly located.
 - c) Install three (3) screws into U-nuts

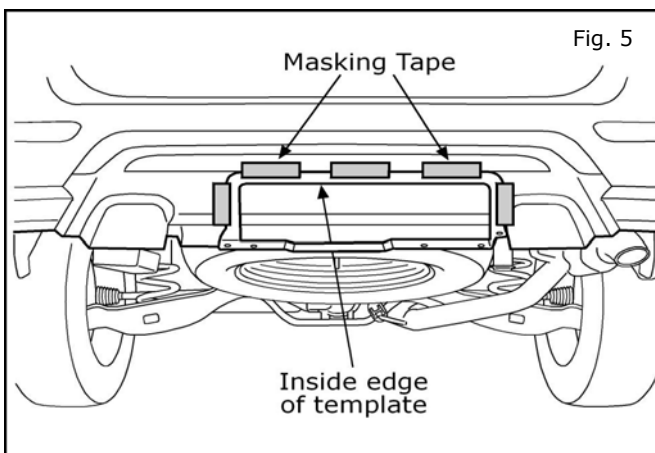

NOTE:

Apply pressure to be sure template is positioned firmly against the bumper surface.

- 6) Apply masking tape around all outside edges of template to secure it to bumper, as shown in fig 4.

CAUTION

- **Safety glasses required beyond this step.**

10. INSTALLATION PROCEDURE

- 7) Remove any tape that covers inside edge of template.
- 8) Drill holes at locations shown in Fig 6 using 8mm (5/16") bit. This will help cutting process in following steps.

NOTE: Be sure Drill Bit is slightly below edges of template.

Fig. 6

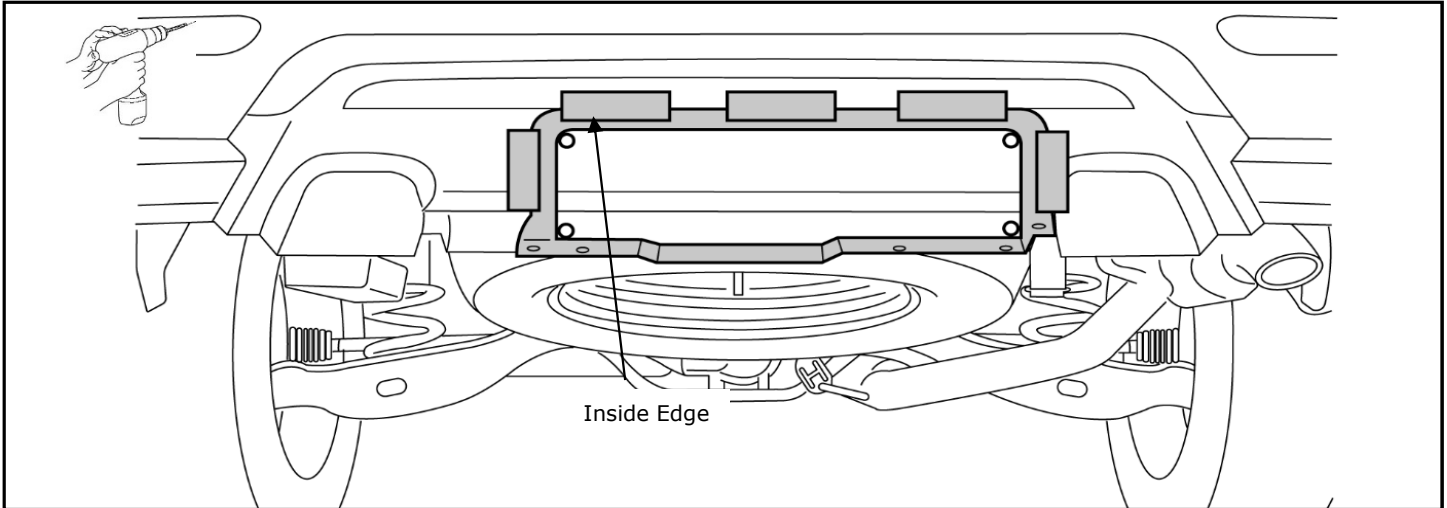

- 9) Use small reciprocating air saw to cut bumper plastic and connect holes previously drilled in step above. Follow edge of template and work carefully from one hole to next until complete.

NOTE: Move slowly and firmly to keep the bit against the cutt

CAUTION

Be aware of vehicle parts behind this area.

Fig. 7

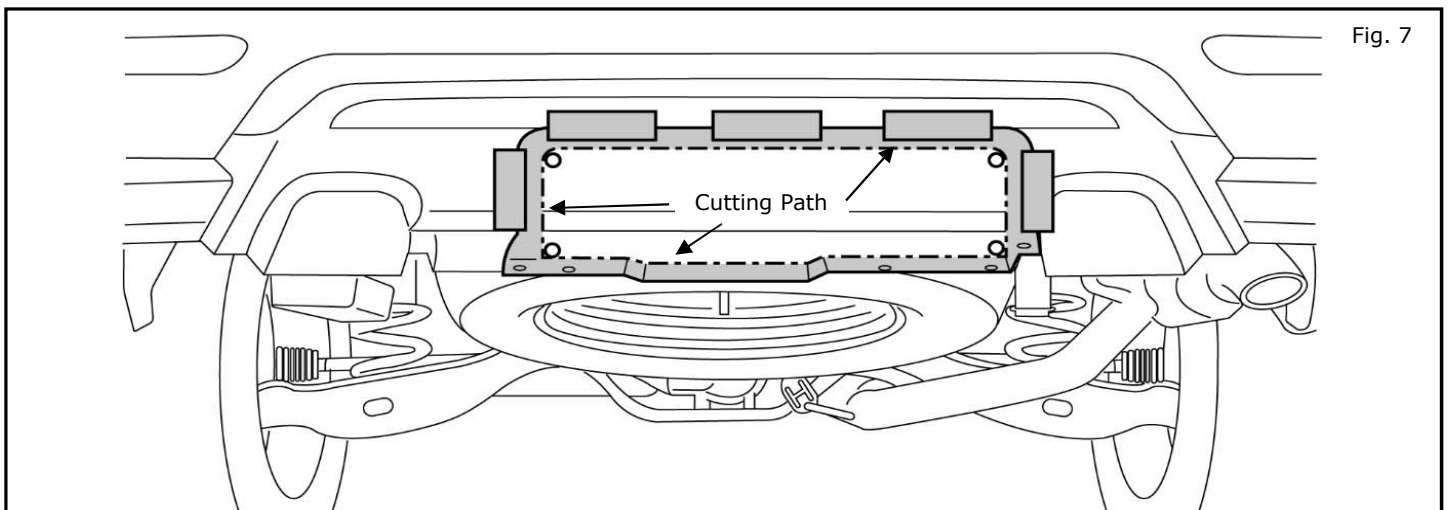

11. INSTALLATION PROCEDURE

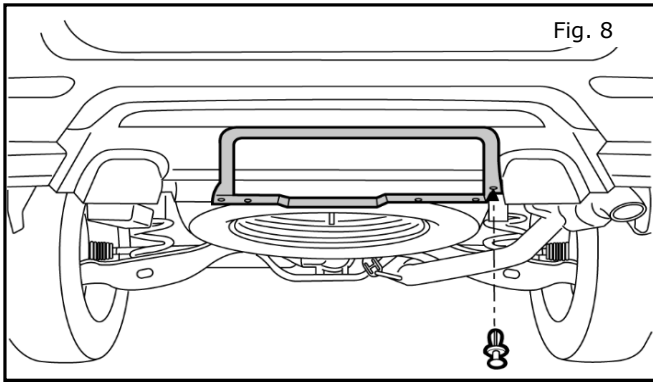

- 10) Remove cutting template:
 - a) Remove all masking tape.
 - b) Use flathead screwdriver, remove trim clip from cutting template.
 - c) Remove screws (3) from bottom of cutting template.
 - d) Re-install trim clip to attach bumper to bracket. Reference Step. 3.

NOTE:

Remove any burrs and cut area to ensure proper fit of Hitch Finisher when installed.

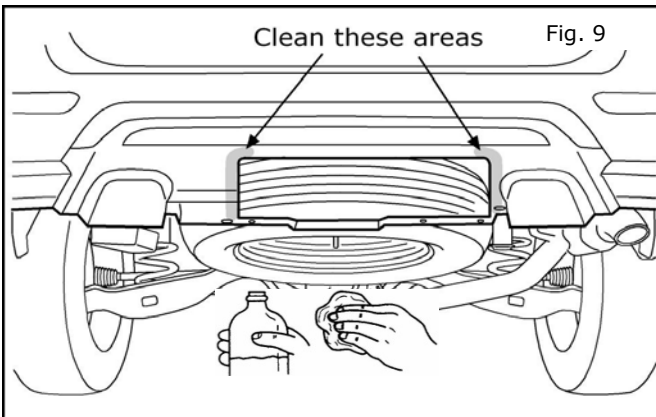

- 11) Use a clean, lint-free cloth and clean installation surface (shaded area) with isopropyl alcohol and water solution. Use at least 90% alcohol solution.
 - a) Allow alcohol to dry completely.

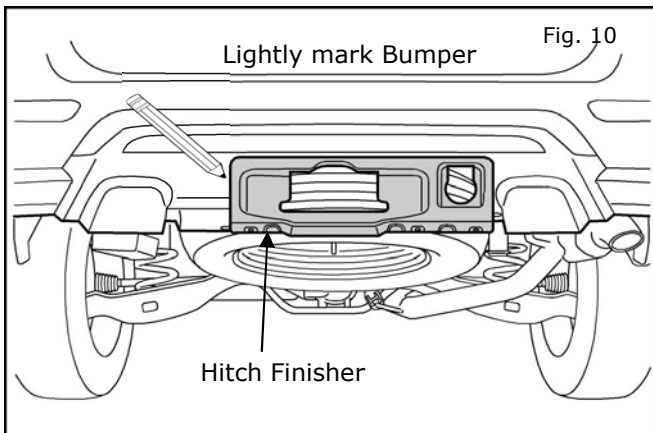

- 12) Position Hitch Finisher against bumper. Push and hold Finisher in upward position as shown in Fig.10. Make sure Hitch Finisher lugs are fully engaged with bumper. Reference Fig. 11.

NOTE:

DO NOT remove tape liners at this point.

- 13) Use #2 pencil to lightly mark bumper as shown in Fig 10.
- 14) Remove hitch finisher.

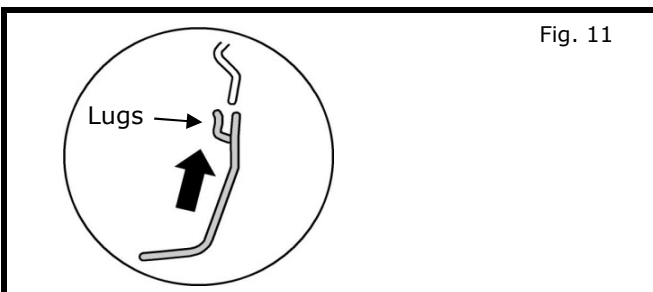

11. INSTALLATION PROCEDURE

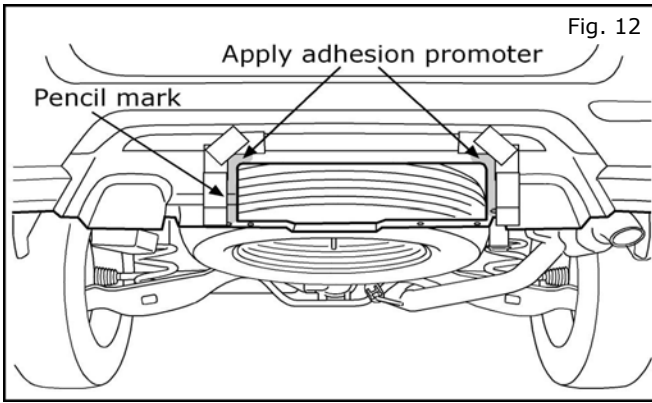

- 15) Apply masking tape to slightly cover pencil mark as shown to protect visible areas from adhesion promoter. See Fig 12.

NOTE:

Tape should line up with pencil mark as shown.

- 16) Apply Adhesion promoter to shaded area in Fig 12.
- Apply thin, uniform coating to shaded area, using minimum amount to fully coat surface.
 - Remove masking tape immediately.
 - Wait two minutes and not more than one hour to complete installation.

NOTE:

Wear hand protection when working with adhesion promoter.

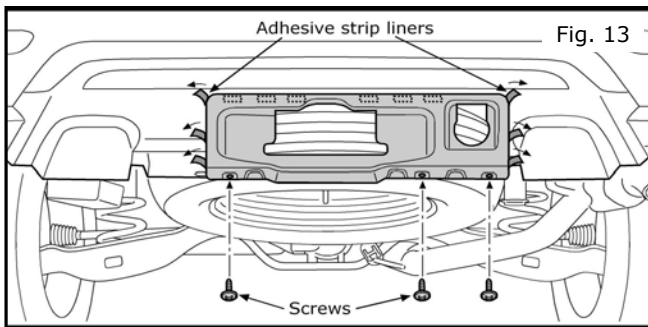

- 18) Carefully fold back pull tabs on tape so they are exposed per Fig 13.
- 19) Reposition Hitch Cover against bumper. Press firmly to engage all lugs and clips into bumper opening.
- 20) Firmly grip each tape liner and carefully pull tape liner downwards to remove. Make sure the liner is completely removed.
- 21) Use a roller or burnish by hand to apply a minimum of 15lbs of pressure along length of tape (starting at top of part and working downward).
- 22) Install and tighten three (3) screws into the u-nuts at the bottom of bumper.

12. CHECK OUT

Inspect the vehicle for unfinished work.

- 1) Check the Hitch Finisher for proper fit and finish. Be sure no gaps are visible.
- 2) Be sure all clips are securely fastened.